

# 2SA1127

## Silicon PNP epitaxial planer type

For low-frequency and low-noise amplification  
Complementary to 2SC2634

### Features

- Low noise characteristics.
- High forward current transfer ratio  $h_{FE}$ .

### Absolute Maximum Ratings (Ta=25°C)

Parameter	Symbol	Ratings	Unit
Collector to base voltage	$V_{CBO}$	-60	V
Collector to emitter voltage	$V_{CEO}$	-55	V
Emitter to base voltage	$V_{EBO}$	-7	V
Peak collector current	$I_{CP}$	-200	mA
Collector current	$I_C$	-100	mA
Collector power dissipation	$P_C$	400	mW
Junction temperature	$T_j$	150	°C
Storage temperature	$T_{stg}$	-55 ~ +150	°C

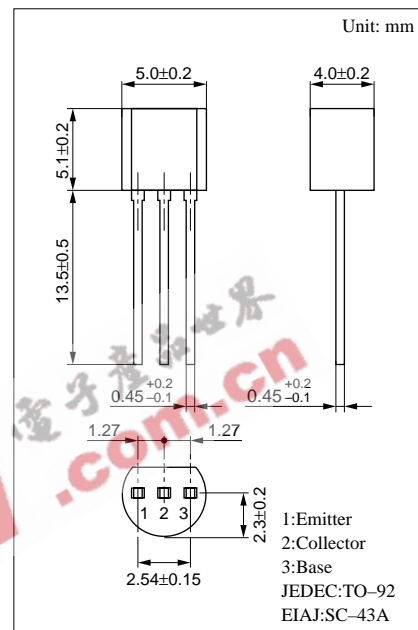

### Electrical Characteristics (Ta=25°C)

Parameter	Symbol	Conditions	min	typ	max	Unit
Collector cutoff current	$I_{CBO}$	$V_{CB} = -10V, I_E = 0$		-1	-100	nA
	$I_{CEO}$	$V_{CE} = -10V, I_B = 0$		-0.01	-1	μA
Collector to base voltage	$V_{CBO}$	$I_C = -10\mu A, I_E = 0$	-60			V
Collector to emitter voltage	$V_{CEO}$	$I_C = -1mA, I_B = 0$	-55			V
Emitter to base voltage	$V_{EBO}$	$I_E = -10\mu A, I_C = 0$	-7			V
Forward current transfer ratio	$h_{FE}^*$	$V_{CE} = -5V, I_C = -2mA$	180		700	
Collector to emitter saturation voltage	$V_{CE(sat)}$	$I_C = -100mA, I_B = -10mA$			-0.6	V
Base to emitter voltage	$V_{BE}$	$V_{CE} = -1V, I_C = -30mA$			-1	V
Transition frequency	$f_T$	$V_{CB} = -5V, I_E = 2mA, f = 200MHz$		200		MHz
Noise voltage	NV	$V_{CE} = -10V, I_C = -1mA, G_V = 80dB$ $R_g = 100k\Omega, Function = FLAT$			150	mV

\* $h_{FE}$  Rank classification

Rank	R	S	T
$h_{FE}$	180 ~ 360	260 ~ 520	360 ~ 700

