

2SC2634

Silicon NPN epitaxial planer type

For low-frequency and low-noise amplification
Complementary to 2SA1127

Features

- Low noise voltage NV.
- High forward current transfer ratio h_{FE} .

Absolute Maximum Ratings (Ta=25°C)

Parameter	Symbol	Ratings	Unit
Collector to base voltage	V_{CBO}	60	V
Collector to emitter voltage	V_{CEO}	55	V
Emitter to base voltage	V_{EBO}	7	V
Peak collector current	I_{CP}	200	mA
Collector current	I_C	100	mA
Collector power dissipation	P_C	400	mW
Junction temperature	T_j	150	°C
Storage temperature	T_{stg}	-55 ~ +150	°C

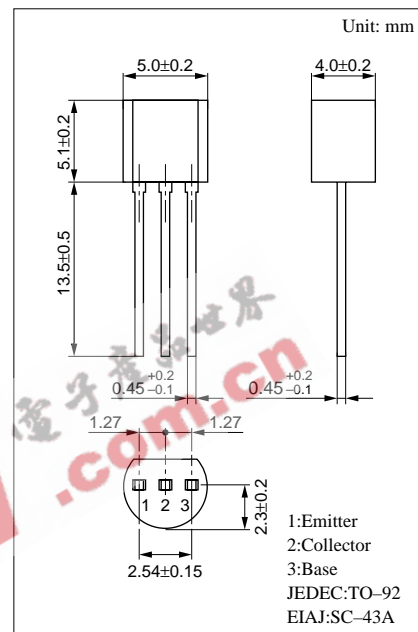

Electrical Characteristics (Ta=25°C)

Parameter	Symbol	Conditions	min	typ	max	Unit
Collector cutoff current	I_{CBO}	$V_{CB} = 10V, I_E = 0$		1	100	nA
	I_{CEO}	$V_{CE} = 10V, I_B = 0$		0.01	1	μA
Collector to base voltage	V_{CBO}	$I_C = 10\mu A, I_E = 0$	60			V
Collector to emitter voltage	V_{CEO}	$I_C = 1mA, I_B = 0$	55			V
Emitter to base voltage	V_{EBO}	$I_E = 10\mu A, I_C = 0$	7			V
Forward current transfer ratio	h_{FE}^*	$V_{CE} = 5V, I_C = 2mA$	180		700	
Collector to emitter saturation voltage	$V_{CE(sat)}$	$I_{CE} = 100mA, I_B = 10mA$			0.6	V
Base to emitter voltage	V_{BE}	$V_{CE} = 1V, I_C = 30mA$			1	V
Transition frequency	f_T	$V_{CB} = 5V, I_E = -2mA, f = 200MHz$		200		MHz
Noise voltage	NV	$V_{CE} = 10V, I_C = 1mA, G_V = 80dB$ $R_g = 100k\Omega, \text{Function} = \text{FLAT}$			150	mV

* h_{FE} Rank classification

Rank	R	S	T
h_{FE}	180 ~ 360	260 ~ 520	360 ~ 700

