

9097250 TOSHIBA (DISCRETE/OPTO)

56C 07451 DT-33-11

**2SC1617**

SILICON NPN TRIPLE DIFFUSED TYPE

BLACK AND WHITE TV HORIZONTAL OUTPUT  
APPLICATIONS.

## FEATURES;

- High Voltage :  $V_{CBO}=300V$
- Wide Safe Operating Area.

## MAXIMUM RATINGS (Ta=25°C)

CHARACTERISTIC	SYMBOL	RATING	UNIT
Collector-Base Voltage	$V_{CBO}$	300	V
Collector-Emitter Voltage	$V_{CEO}$	100	V
Emitter-Base Voltage	$V_{EBO}$	5	V
Collector Current	$I_C$	7	A
Emitter Current	$I_E$	-7	A
Collector Power Dissipation	$P_C$	50	W
Junction Temperature	$T_j$	150	°C
Storage Temperature Range	$T_{stg}$	-55~150	°C

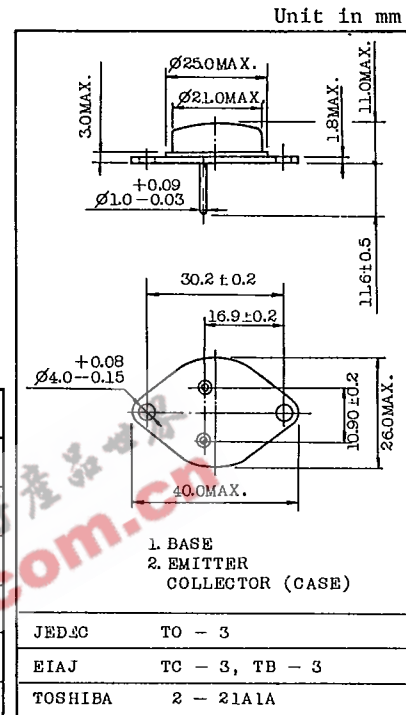

Mounting kit No. AC73  
Weight : 12.0g

## ELECTRICAL CHARACTERISTICS (Ta=25°C)

CHARACTERISTIC		SYMBOL	TEST CONDITION	MIN.	TYP.	MAX.	UNIT
Collector Cut-off Current		$I_{CBO}$	$V_{CB}=250V, I_E=0$	-	-	1.0	mA
Emitter Cut-off Current		$I_{EBO}$	$V_{EB}=5V, I_C=0$	-	-	1.0	mA
DC Current Gain		$h_{FE(1)}$	$V_{CE}=5V, I_C=1A$	30	-	150	
		$h_{FE(2)}$	$V_{CE}=5V, I_C=7A$	15	-	-	
Saturation Voltage	Collector-Emitter	$V_{CE(sat)}$	$I_C=5A, I_B=0.5A$	-	-	1.2	V
	Base-Emitter	$V_{BE(sat)}$	$I_C=5A, I_B=0.5A$	-	-	1.5	
Transition Frequency		$f_T$	$V_{CE}=5V, I_C=0.5A$	-	10	-	MHz

STATIC CHARACTERISTICS

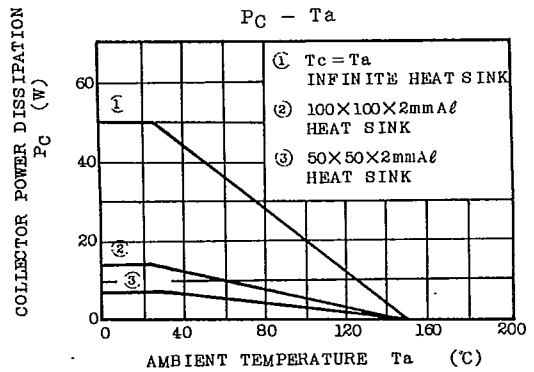
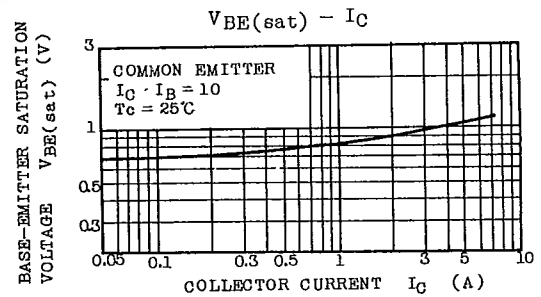
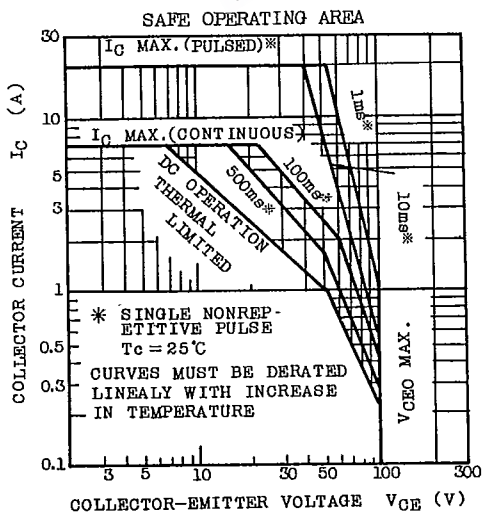
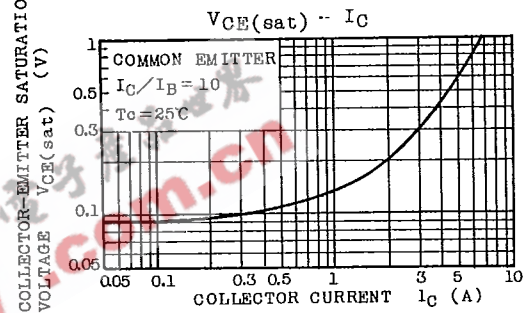
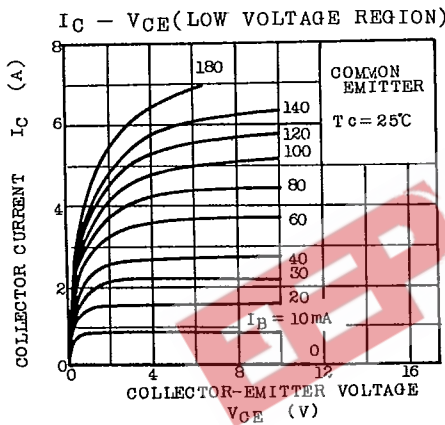
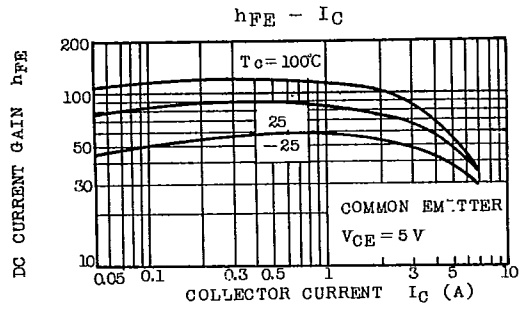
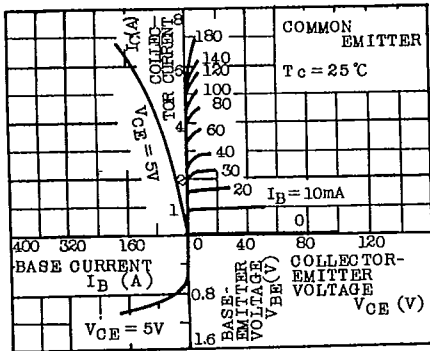

TOSHIBA CORPORATION