

**DESCRIPTION** The 2SC2787 is designed for use in AM converter, AM/FM IF amplifier and local oscillator of AM/FM tuner.

- FEATURES**
- Small output capacitance ( $C_{ob} = 1.9 \text{ pF TYP.}$ )
  - Low noise figure ( $NF = 2.0 \text{ dB TYP. @1.0 MHz}$ )

**ABSOLUTE MAXIMUM RATINGS**

- Maximum Temperatures
- Storage Temperature .....  $-55 \text{ to } +150 \text{ }^\circ\text{C}$
  - Junction Temperature .....  $+150 \text{ }^\circ\text{C}$  Maximum
- Maximum Power Dissipation ( $T_a = 25 \text{ }^\circ\text{C}$ )
- Total Power Dissipation .....  $250 \text{ mW}$
- Maximum Voltages and Currents ( $T_a = 25 \text{ }^\circ\text{C}$ )
- $V_{CBO}$  Collector to Base Voltage .....  $50 \text{ V}$
  - $V_{CEO}$  Collector to Emitter Voltage .....  $30 \text{ V}$
  - $V_{EBO}$  Emitter to Base Voltage .....  $5.0 \text{ V}$
  - $I_C$  Collector Current .....  $30 \text{ mA}$
  - $I_B$  Base Current .....  $30 \text{ mA}$

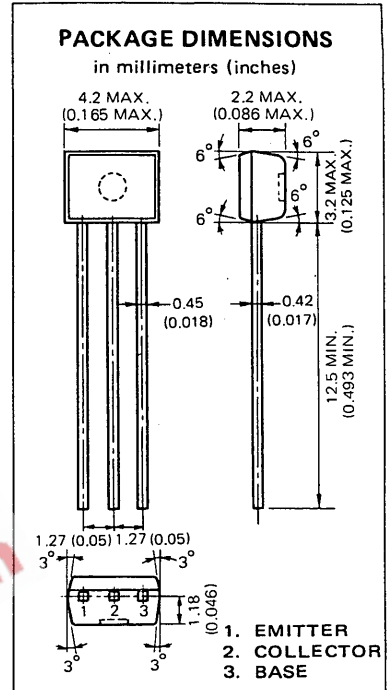

**ELECTRICAL CHARACTERISTICS ( $T_a = 25 \text{ }^\circ\text{C}$ )**

SYMBOL	CHARACTERISTIC	MIN.	TYP.	MAX.	UNIT	TEST CONDITIONS
$h_{FE}$	DC Current Gain	40	90	180	—	$V_{CE}=6.0 \text{ V}, I_C=1.0 \text{ mA}$
$C_{ob}$	Output Capacitance		1.9	2.2	pF	$V_{CB}=6.0 \text{ V}, I_E=0, f=1.0 \text{ MHz}$
NF	Noise Figure		2.0	4.0	dB	$V_{CE}=6.0 \text{ V}, I_E=-1.0 \text{ mA}, R_G=500 \text{ } \Omega, f=1.0 \text{ MHz}$
$f_T$	Gain Bandwidth Product	150	250		MHz	$V_{CE}=6.0 \text{ V}, I_E=-1.0 \text{ mA}$
$C_c-rb'b$	Collector to Base Time Constant		10	15	ps	$V_{CE}=6.0 \text{ V}, I_E=-10 \text{ mA}, f=31.9 \text{ MHz}$
$I_{CBO}$	Collector Cutoff Current			100	nA	$V_{CB}=50 \text{ V}, I_E=0$
$I_{EBO}$	Emitter Cutoff Current			100	nA	$V_{EB}=5.0 \text{ V}, I_C=0$
$V_{BE}$	Base to Emitter Voltage	0.65	0.70	0.75	V	$V_{CE}=6.0 \text{ V}, I_C=1.0 \text{ mA}$
$V_{CE(sat)}$	Collector Saturation Voltage		0.08	0.30	V	$I_C=10 \text{ mA}, I_B=1.0 \text{ mA}$

**Classification of  $h_{FE}$**

Rank	MF	LF	KF
Range	40 - 80	60 - 120	90 - 180

$h_{FE}$  Test Conditions :  $V_{CE}=6.0 \text{ V}, I_C=1.0 \text{ mA}$

TYPICAL CHARACTERISTICS (Ta = 25 °C unless otherwise noted)

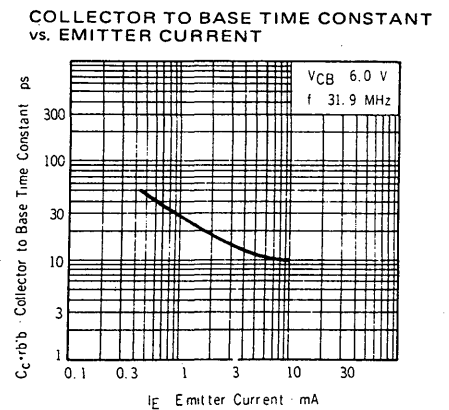
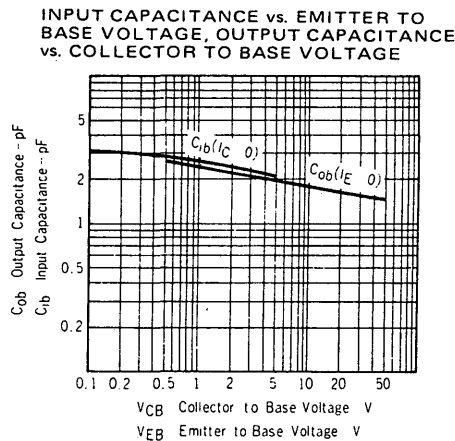
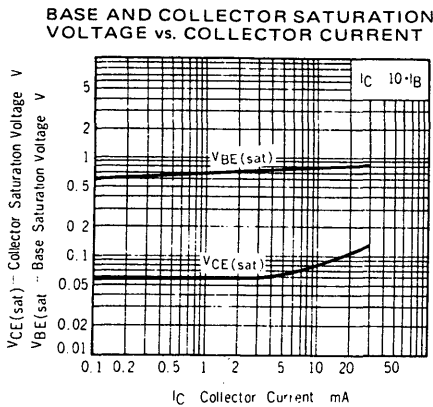
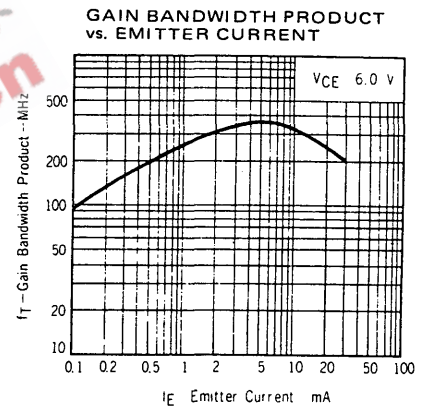
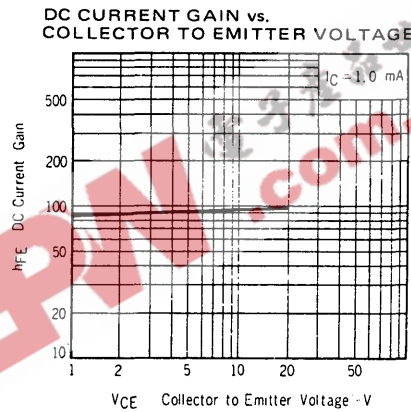
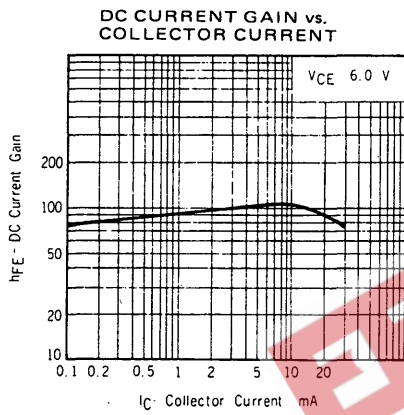
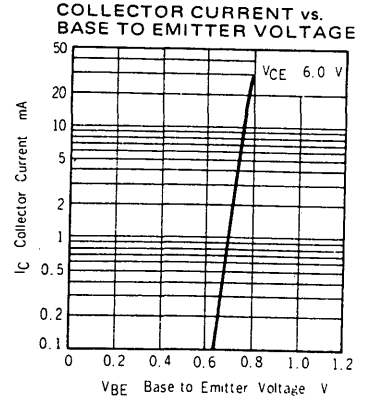
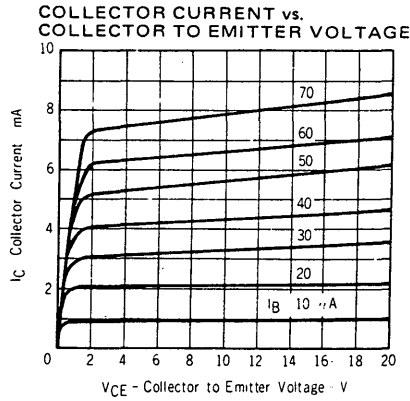
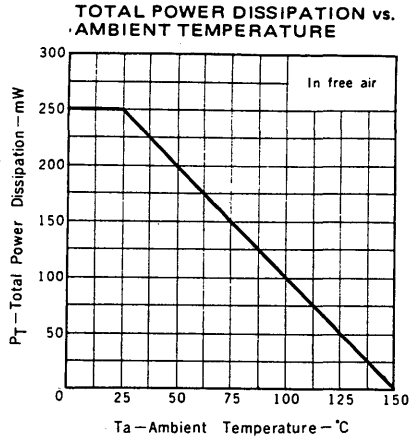

INPUT ADMITTANCE vs. COLLECTOR CURRENT

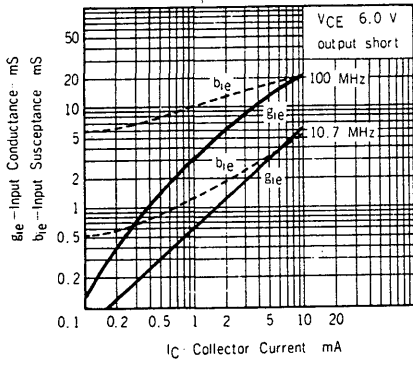

REVERSE TRANSFER ADMITTANCE vs. COLLECTOR CURRENT

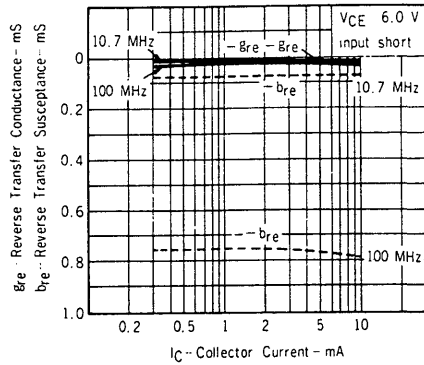

FORWARD TRANSFER ADMITTANCE vs. COLLECTOR CURRENT

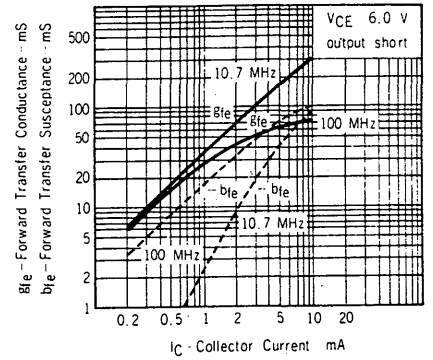

OUTPUT ADMITTANCE vs. COLLECTOR CURRENT

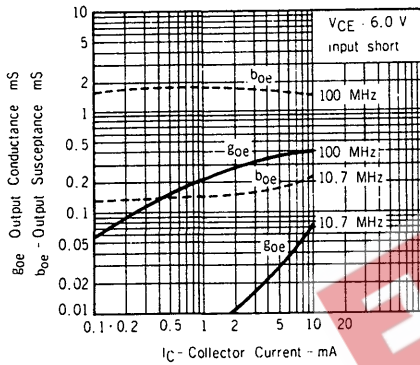

FORWARD TRANSFER ADMITTANCE vs. COLLECTOR CURRENT

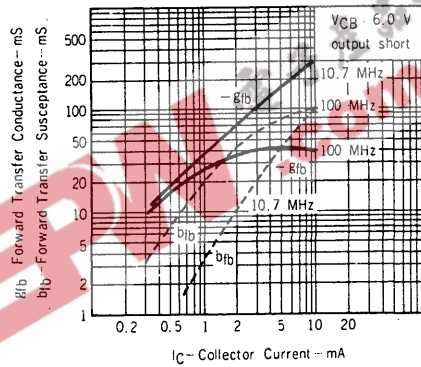

REVERSE TRANSFER ADMITTANCE vs. COLLECTOR CURRENT

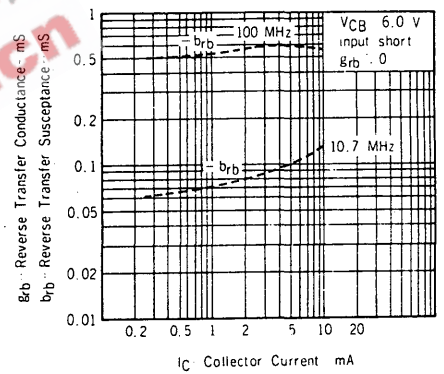

INPUT ADMITTANCE vs. COLLECTOR CURRENT

