

UTC2SC2482

NPN EPITAXIAL SILICON TRANSISTOR

NPN EPITAXIAL PLANAR TRANSISTOR

APPLICATIONS

- *HIGH VOLTAGE SWITCHING AND AMPLIFIER APPLICATIONS
- *COLOR TV HORIZ. DRIVER APPLICATIONS
- *COLOR TV CHROMA OUTPUT APPLICATIONS

FEATURES

- *High Voltage :V(BR)CEO= 300V
- *Small Collector Output Capacitance: Cob=3.0pF(Typ.)

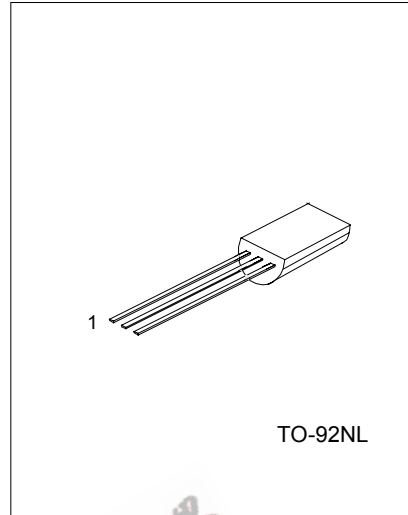

1:EMITTER 2:COLLECTOR 3:BASE

ABSOLUTE MAXIMUM RATINGS (Ta=25°C)

PARAMETER	SYMBOL	LIMITS	UNIT
Collector-Base Voltage	V _{CB0}	300	V
Collector-Emitter Voltage	V _{CEO}	300	V
Emitter-Base Voltage	V _{EB0}	7	V
Collector Current	I _c	100	mA
Base Current	I _b	50	mA
Collector Power Dissipation	P _c	900	mW
Junction Temperature	T _j	150	°C
Storage Temperature	T _{STG}	-55 ~ +150	°C

ELECTRICAL CHARACTERISTICS (Ta=25°C, unless otherwise specified)

PARAMETER	SYMBOL	TEST CONDITIONS	MIN	TYP	MAX	UNIT
Collector Cut-Off Current	I _{cBO}	V _{CB} =240V I _E = 0			1.0	μA
Emitter Cut-Off Current	I _{EBO}	V _{EB} = 7V I _c =0			1.0	μA
DC Current Gain	h _{FE} (1)	V _{CE} =10V, I _c =4mA	20			
	h _{FE} (2)	V _{CE} =10V, I _c =20mA	30		150	
Collector-Emitter Saturation Voltage	V _{CE(sat)}	I _c =10mA, I _b =1mA			1.0	V
Base- Emitter Saturation Voltage	V _{BE(sat)}	I _c =10mA, I _b =1mA			1.0	V
Transition Frequency	f _T	V _{CE} =10V, I _c =20mA	50			MHz
Collector Output Capacitance	C _{ob}	V _{CB} =20V, I _E = 0, f=1MHz		3.0		pF

UTC2SC2482 NPN EPITAXIAL SILICON TRANSISTOR

ELECTRICAL CHARACTERISTICS CURVES

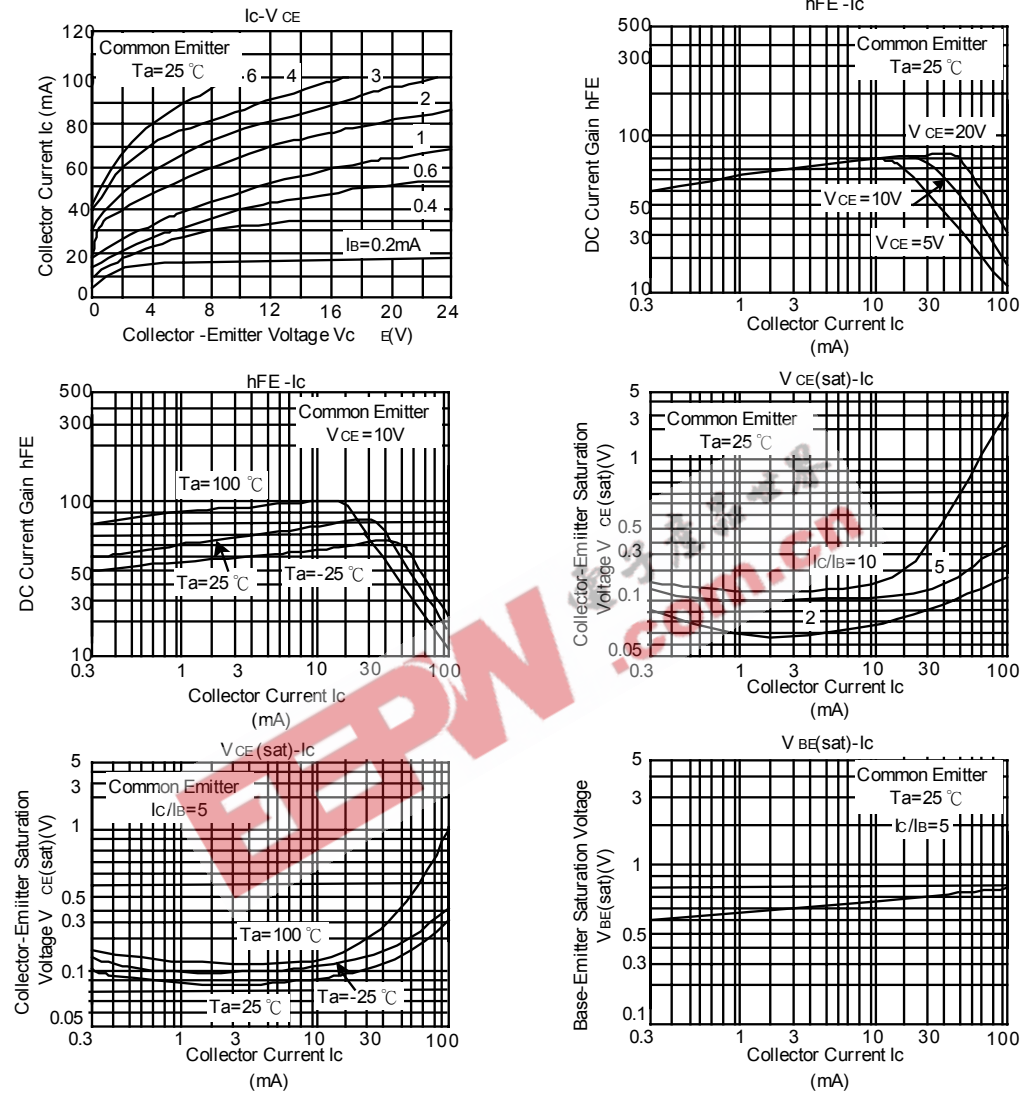

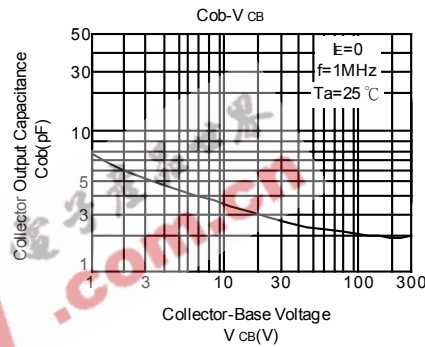
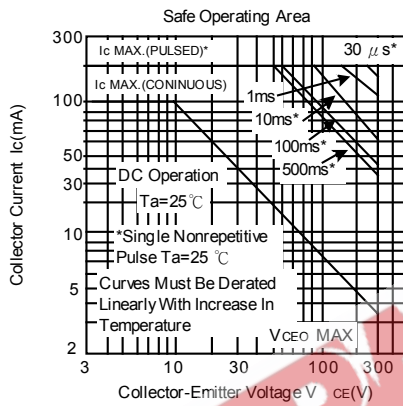
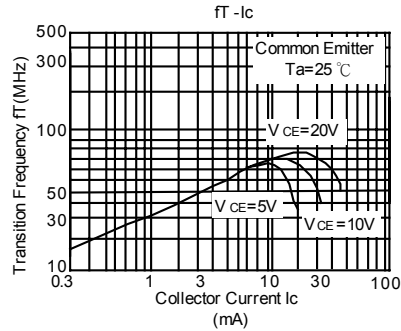
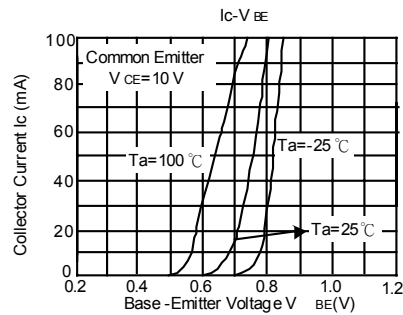

UTC assumes no responsibility for equipment failures that result from using products at values that exceed, even momentarily, rated values (such as maximum ratings, operating condition ranges, or other parameters) listed in products specifications of any and all UTC products described or contained herein. UTC products are not designed for use in life support appliances, devices or systems where malfunction of these products can be reasonably expected to result in personal injury. Reproduction in whole or in part is prohibited without the prior written consent of the copyright owner. The information presented in this document does not form part of any quotation or contract, is believed to be accurate and reliable and may be changed without notice.