

> **Features**

- High Current
- Low On-Resistance
- No Secondary Breakdown
- Low Driving Power
- High Forward Transconductance
- Avalanche Proof
- Including G-S Zener-Diode

> **Applications**

- Motor Control
- General Purpose Power Amplifier
- DC-DC Converters

> **Outline Drawing**

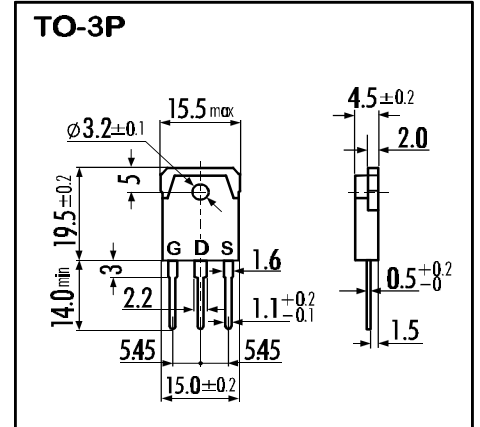

> **Maximum Ratings and Characteristics**

- Absolute Maximum Ratings ( $T_C=25^\circ\text{C}$ ), unless otherwise specified

Item	Symbol	Rating	Unit
Drain-Source-Voltage	$V_{DS}$	60	V
Drain-Gate-Voltage ( $R_{GS}=20K\Omega$ )	$V_{DGR}$	60	V
Continous Drain Current	$I_D$	50	A
Pulsed Drain Current	$I_{D(puls)}$	200	A
Gate-Source-Voltage	$V_{GS}$	$\pm 20$	V
Max. Power Dissipation	$P_D$	125	W
Operating and Storage Temperature Range	$T_{ch}$	150	$^\circ\text{C}$
	$T_{stg}$	-55 ~ +150	$^\circ\text{C}$

> **Equivalent Circuit**

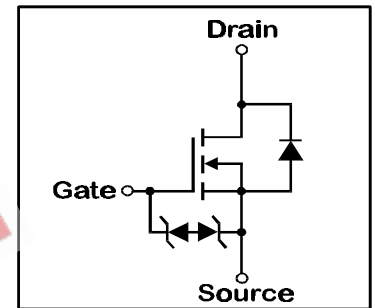

- Electrical Characteristics ( $T_C=25^\circ\text{C}$ ), unless otherwise specified

Item	Symbol	Test conditions	Min.	Typ.	Max.	Unit
Drain-Source Breakdown-Voltage	$V_{(BR)DSS}$	$I_D=1\text{mA}$ $V_{GS}=0\text{V}$	60			V
Gate Threshold Voltage	$V_{GS(th)}$	$I_D=1\text{mA}$ $V_{DS}=V_{GS}$	1,0	1,5	2,0	V
Zero Gate Voltage Drain Current	$I_{DSS}$	$V_{DS}=60\text{V}$ $T_{ch}=25^\circ\text{C}$			500	$\mu\text{A}$
		$V_{GS}=0\text{V}$ $T_{ch}=125^\circ\text{C}$			1,0	mA
Gate Source Leakage Current	$I_{GSS}$	$V_{GS}=\pm 16\text{V}$ $V_{DS}=0\text{V}$			10,0	$\mu\text{A}$
Drain Source On-State Resistance	$R_{DS(on)}$	$I_D=25\text{A}$ $V_{GS}=4\text{V}$		0,019	0,027	$\Omega$
		$I_D=25\text{A}$ $V_{GS}=10\text{V}$		0,013	0,017	$\Omega$
Forward Transconductance	$g_{fs}$	$I_D=25\text{A}$ $V_{DS}=25\text{V}$	20	40		S
Input Capacitance	$C_{iss}$	$V_{DS}=25\text{V}$		2600	3900	pF
Output Capacitance	$C_{oss}$	$V_{GS}=0\text{V}$		1000	1500	pF
Reverse Transfer Capacitance	$C_{rss}$	$f=1\text{MHz}$		630	950	pF
Turn-On-Time $t_{on}$ ( $t_{on}=t_{d(on)}+t_r$ )	$t_{d(on)}$	$V_{CC}=30\text{V}$		20	30	ns
		$I_D=50\text{A}$		210	320	ns
Turn-Off-Time $t_{off}$ ( $t_{off}=t_{d(off)}+t_f$ )	$t_{d(off)}$	$V_{GS}=10\text{V}$		520	780	ns
		$R_{GS}=25\Omega$		420	630	ns
Avalanche Capability	$I_{AV}$	$L=100\mu\text{H}$ $T_{ch}=25^\circ\text{C}$	50			A
Continous Reverse Drain Current	$I_{DR}$				50	A
Pulsed Reverse Drain Current	$I_{DRM}$				200	A
Diode Forward On-Voltage	$V_{SD}$	$I_F=2I_{DR}$ $V_{GS}=0\text{V}$ $T_{ch}=25^\circ\text{C}$		1,45	2,18	V
Reverse Recovery Time	$t_{rr}$	$I_F=I_{DR}$ $V_{GS}=0\text{V}$		85	120	ns
Reverse Recovery Charge	$Q_{rr}$	$-dI_F/dt=100\text{A}/\mu\text{s}$ $T_{ch}=25^\circ\text{C}$		0,16		$\mu\text{C}$

- Thermal Characteristics

Item	Symbol	Test conditions	Min.	Typ.	Max.	Unit
Thermal Resistance	$R_{th(ch-a)}$	channel to air			35	$^\circ\text{C}/\text{W}$
	$R_{th(ch-c)}$	channel to case			1,0	$^\circ\text{C}/\text{W}$

N-channel MOS-FET			
60V	0,017Ω	50A	125W

# 2SK1969-01

## FAP-III A Series



### > Characteristics

Typical Output Characteristics

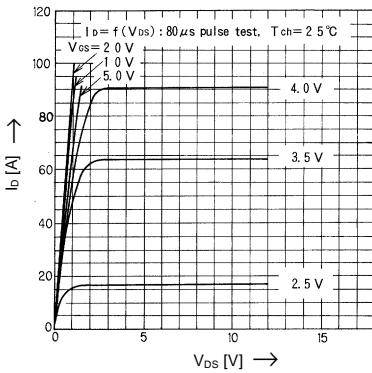

Drain-Source-On-State Resistance vs. T<sub>ch</sub>

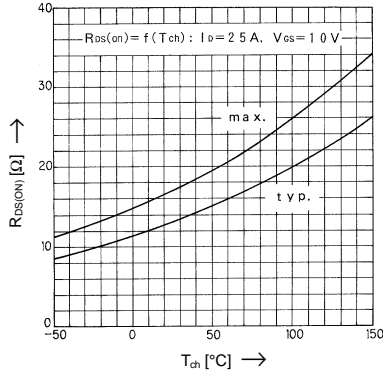

Typical Transfer Characteristics

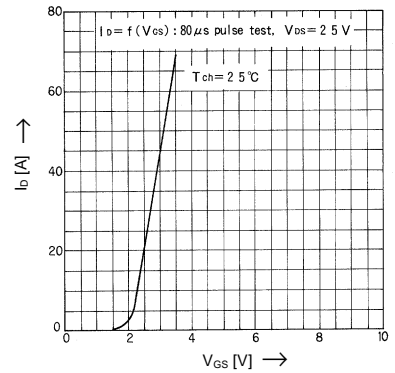

Typical Drain-Source-On-State-Resistance vs. Id

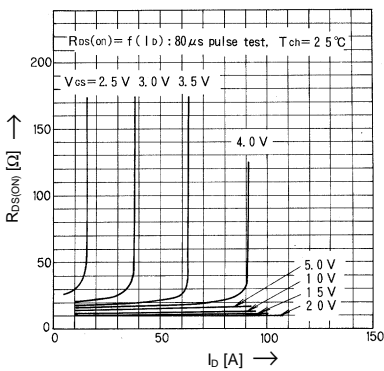

Typical Forward Transconductance vs. Id

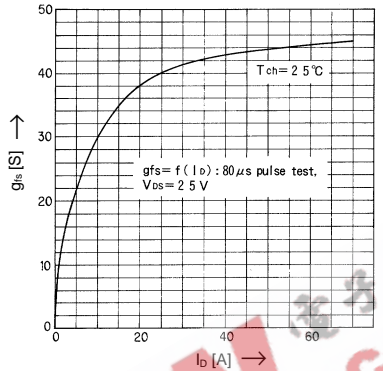

Gate Threshold Voltage vs. T<sub>ch</sub>

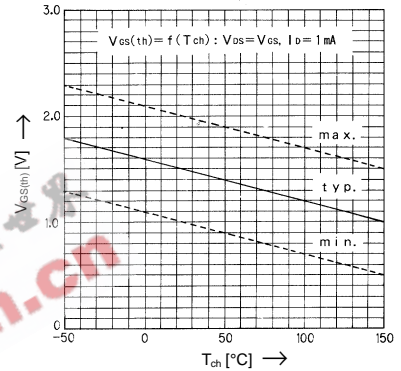

Typical Capacitance vs. V<sub>DS</sub>

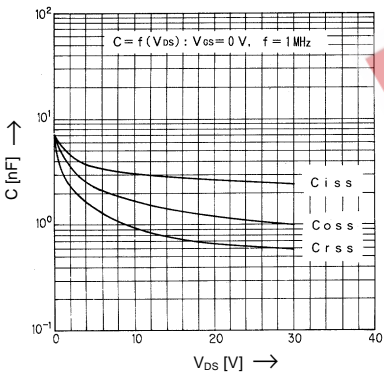

Typical Input Charge

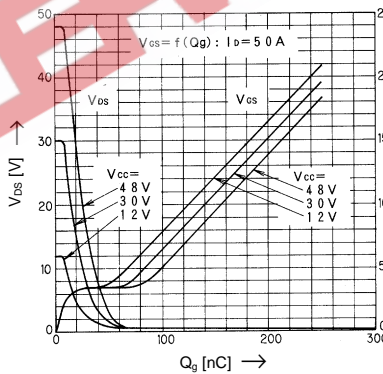

Forward Characteristics of Reverse Diode

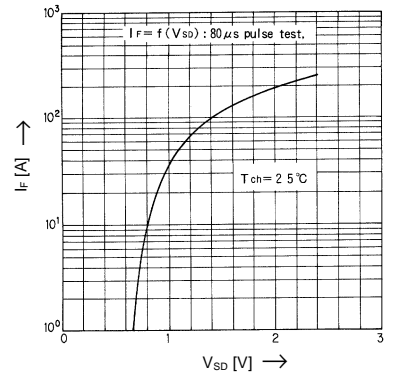

Allowable Power Dissipation vs. T<sub>C</sub>

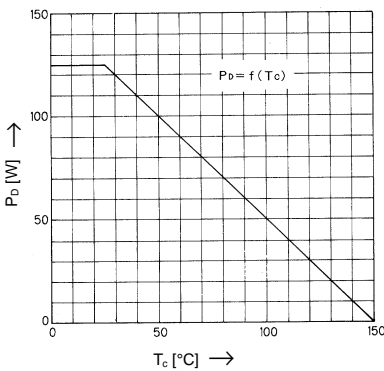

Safe operation area

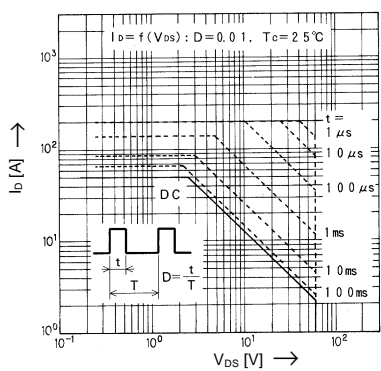

Z<sub>th(j-c)</sub> [K/W]

Transient Thermal impedance

