

> **Features**

- High Speed Switching
- Low On-Resistance
- No Secondary Breakdown
- Low Driving Power
- High Voltage
- $V_{GS} = \pm 30V$ Guarantee
- Avalanche Proof

> **Applications**

- Switching Regulators
- UPS
- DC-DC converters
- General Purpose Power Amplifier

> **Outline Drawing**

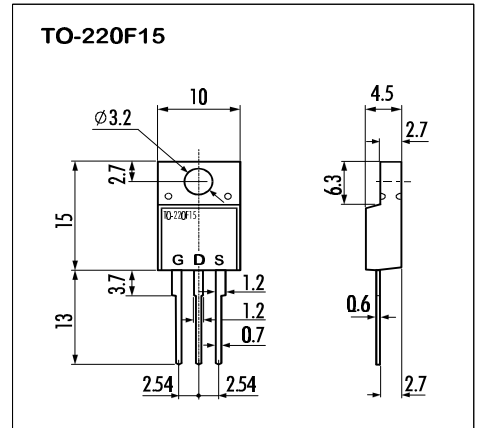

> **Maximum Ratings and Characteristics**

- Absolute Maximum Ratings ($T_C=25^\circ C$), unless otherwise specified

Item	Symbol	Rating	Unit
Drain-Source-Voltage	V_{DS}	200	V
Drain-Gate-Voltage($R_{GS}=20K\Omega$)	V_{DGR}	200	V
Continous Drain Current	I_D	20	A
Pulsed Drain Current	$I_{D(puls)}$	80	A
Gate-Source-Voltage	V_{GS}	± 30	V
Max. Power Dissipation	P_D	50	W
Operating and Storage Temperature Range	T_{ch}	150	$^\circ C$
	T_{stg}	-55 ~ +150	$^\circ C$

> **Equivalent Circuit**

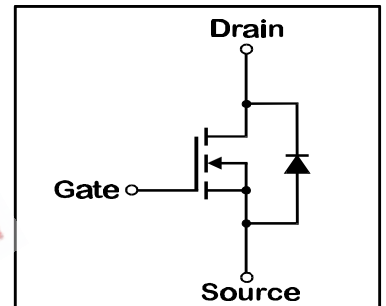

- Electrical Characteristics ($T_C=25^\circ C$), unless otherwise specified

Item	Symbol	Test conditions	Min.	Typ.	Max.	Unit
Drain-Source Breakdown-Voltage	$V_{(BR)DSS}$	$I_D=1mA$ $V_{GS}=0V$	200			V
Gate Threshold Voltage	$V_{GS(th)}$	$I_D=1mA$ $V_{DS}=V_{GS}$	2,5	3,0	3,5	V
Zero Gate Voltage Drain Current	I_{DSS}	$V_{DS}=200V$ $T_{ch}=25^\circ C$		10	500	μA
		$V_{GS}=0V$ $T_{ch}=125^\circ C$		0,2	1,0	mA
Gate Source Leakage Current	I_{GSS}	$V_{GS}=\pm 30V$ $V_{DS}=0V$		10	100	nA
Drain Source On-State Resistance	$R_{DS(on)}$	$I_D=10A$ $V_{GS}=10V$		0,1	0,13	Ω
Forward Transconductance	g_{fs}	$I_D=10A$ $V_{DS}=25V$	7,0	15,0		S
Input Capacitance	C_{iss}	$V_{DS}=25V$		1800	2700	pF
Output Capacitance	C_{oss}	$V_{GS}=0V$		320	480	pF
Reverse Transfer Capacitance	C_{rss}	$f=1MHz$		80	120	pF
Turn-On-Time t_{on} ($t_{on}=t_{d(on)}+t_r$)	$t_{d(on)}$	$V_{CC}=150V$		15	25	ns
	t_r	$I_D=20A$		60	90	ns
Turn-Off-Time t_{off} ($t_{off}=t_{d(off)}+t_f$)	$t_{d(off)}$	$V_{GS}=10V$		65	100	ns
	t_f	$R_{GS}=10\Omega$		60	90	ns
Avalanche Capability	I_{AV}	$L=100\mu H$ $T_{ch}=25^\circ C$	20,0			A
Diode Forward On-Voltage	V_{SD}	$I_F=2I_{DR}$ $V_{GS}=0V$ $T_{ch}=25^\circ C$		1,06	1,59	V
Reverse Recovery Time	t_{rr}	$I_F=I_{DR}$ $V_{GS}=0V$		145		ns
Reverse Recovery Charge	Q_{rr}	$-dI_F/dt=100A/\mu s$ $T_{ch}=25^\circ C$		900		μC

- Thermal Characteristics

Item	Symbol	Test conditions	Min.	Typ.	Max.	Unit
Thermal Resistance	$R_{th(ch-a)}$	channel to air			62,5	$^\circ C/W$
	$R_{th(ch-c)}$	channel to case			2,5	$^\circ C/W$

> Characteristics

Typical Output Characteristics

$I_D=f(V_{DS}); 80\mu s$ pulse test; $T_C=25^\circ C$

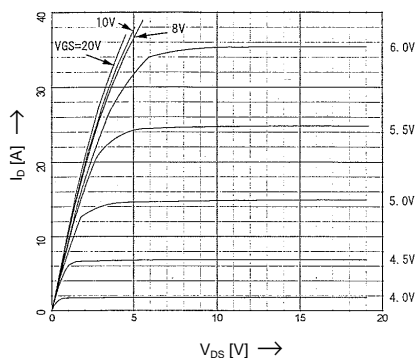

Drain-Source On-State Resistance

$R_{DS(on)}=f(T_{ch}); I_D=10A; V_{GS}=10V$

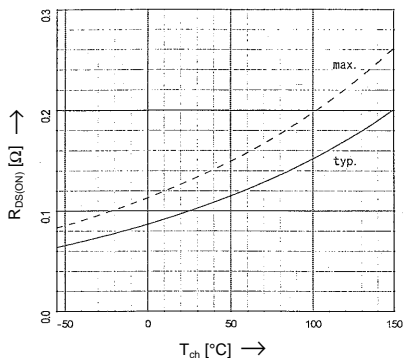

Typical Transfer Characteristics

$I_D=f(V_{GS}); 80\mu s$ pulse test; $V_{DS}=25V; T_{ch}=25^\circ C$

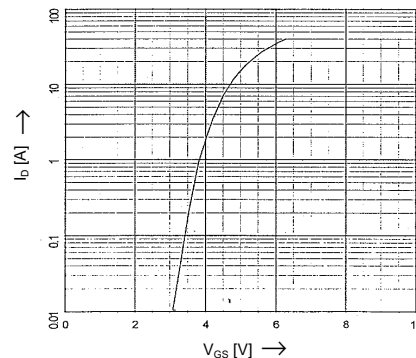

Typical Drain-Source On-State-Resistance

$R_{DS(on)}=f(I_D); T_C=25^\circ C$

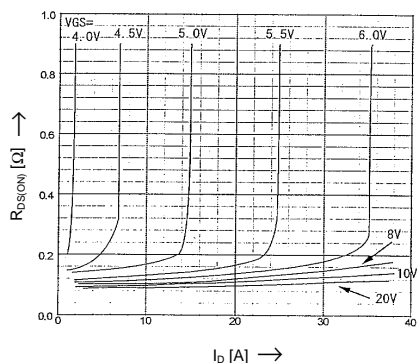

Typical Transconductance

$g_m=f(I_D); 80\mu s$ pulse test; $V_{DS}=25V; T_{ch}=25^\circ C$

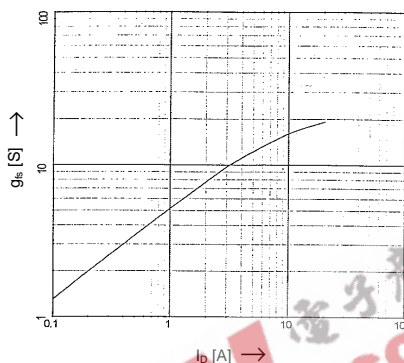

Gate Threshold Voltage

$V_{GS(th)}=f(T_{ch}); I_D=1mA; V_{DS}=V_{GS}$

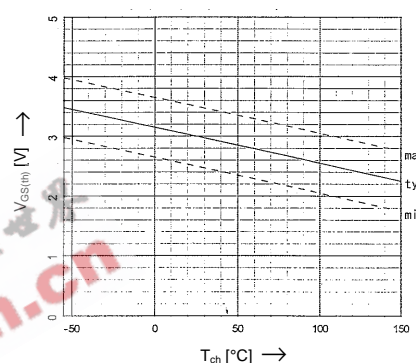

Typical Capacitances

$C=f(V_{DS}); V_{GS}=0V; f=1MHz$

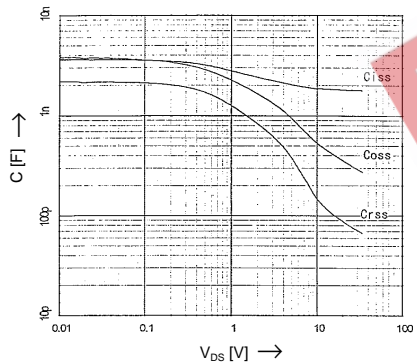

Typical Gate Charge Characteristics

$V_{GS}=f(Q_g); I_D=20A$

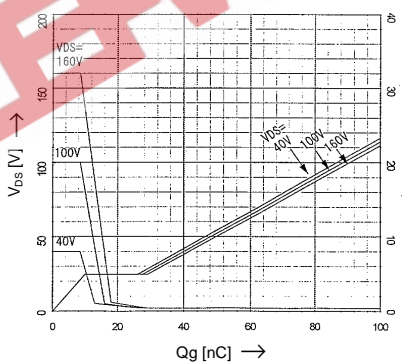

Forward Characteristics of Reverse Diode

$I_F=f(V_{SD}); 80\mu s$ pulse test

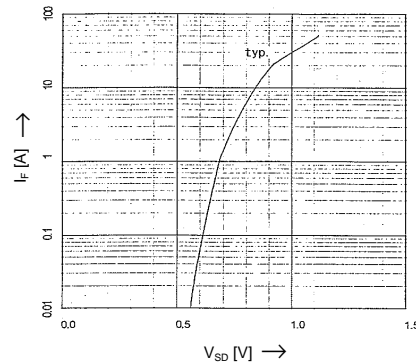

Power Dissipation

$P_D=f(T_C)$

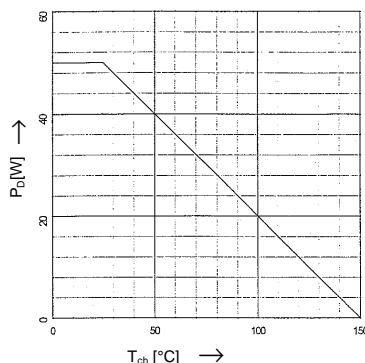

Safe Operation Area

$I_D=f(V_{DS}); D=0,01; T_C=25^\circ C$

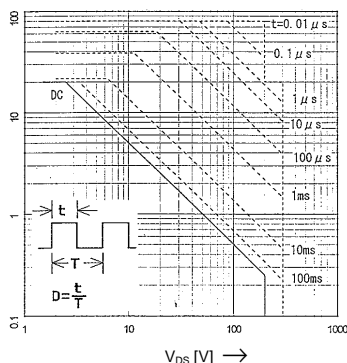

Transient Thermal impedance

Transient Thermal impedance

$Z_{th(j-c)}=f(t)$ parameter: $D=t/T$

