

TOSHIBA FIELD EFFECT TRANSISTOR GaAs N CHANNEL SINGLE GATE MODULATION DOPE TYPE

# 2SK2497

SHF BAND LOW NOISE AMPLIFIER APPLICATIONS.

Unit in mm

- Low Noise Figure : NF=1.2dB (f=12GHz)
- High Gain : Ga=10dB (f=12GHz)

MAXIMUM RATINGS (Ta = 25°C)

CHARACTERISTIC	SYMBOL	RATING	UNIT
Gate-Drain Voltage	V <sub>GDO</sub>	-3	V
Gate-Source Voltage	V <sub>GSO</sub>	-3	V
Drain Current	I <sub>D</sub>	80	mA
Power Dissipation	P <sub>D</sub>	150	mW
Channel Temperature	T <sub>ch</sub>	125	°C
Storage Temperature Range	T <sub>stg</sub>	-55~125	°C

Marking

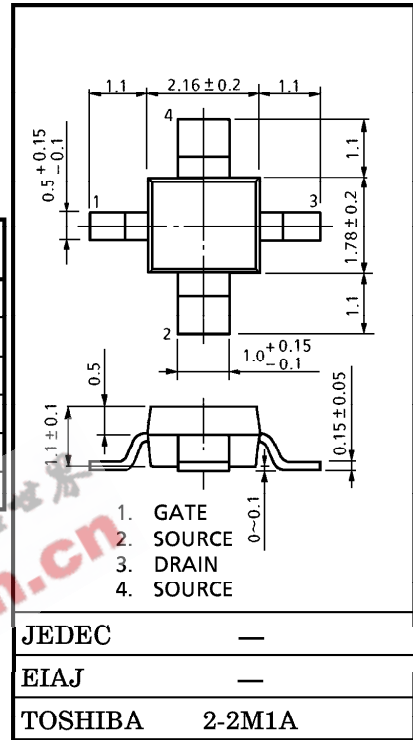
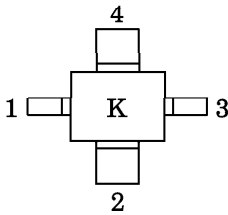

Weight : 0.016g (Typ.)

ELECTRICAL CHARACTERISTICS (Ta = 25°C)

CHARACTERISTIC	SYMBOL	TEST CONDITION	MIN.	TYP.	MAX.	UNIT
Gate Leakage Current	I <sub>GSS</sub>	V <sub>DS</sub> =0, V <sub>GS</sub> =-2V	—	—	-20	μA
Drain Current	I <sub>DSS</sub>	V <sub>DS</sub> =2V, V <sub>GS</sub> =0	15	40	80	mA
Gate-Source Cut-off Voltage	V <sub>GS(OFF)</sub>	V <sub>DS</sub> =2V, I <sub>D</sub> =100μA	-0.2	-0.8	-2	V
Forward Transfer Admittance	Y <sub>fs</sub>	V <sub>DS</sub> =2V, I <sub>D</sub> =10mA, f=1kHz	—	50	—	mS
Noise Figure	NF	V <sub>DS</sub> =2V, I <sub>D</sub> =10mA, f=12GHz	—	1.2	1.6	dB
Associated Gain	Ga	V <sub>DS</sub> =2V, I <sub>D</sub> =10mA, f=12GHz	8.5	10	—	dB

**CAUTION**

GaAs (Gallium Arsenide) is used in this product. The dust or vapor can be dangerous to humans. Do not break, cut, crush or dissolve chemically. Dispose of this product properly according to law. Do not intermingle with normal industrial or domestic waste.

This device electrostatic sensitivity. Please handle with caution.

961001EAC2

● TOSHIBA is continually working to improve the quality and the reliability of its products. Nevertheless, semiconductor devices in general can malfunction or fail due to their inherent electrical sensitivity and vulnerability to physical stress. It is the responsibility of the buyer, when utilizing TOSHIBA products, to observe standards of safety, and to avoid situations in which a malfunction or failure of a TOSHIBA product could cause loss of human life, bodily injury or damage to property. In developing your designs, please ensure that TOSHIBA products are used within specified operating ranges as set forth in the most recent products specifications. Also, please keep in mind the precautions and conditions set forth in the TOSHIBA Semiconductor Reliability Handbook.

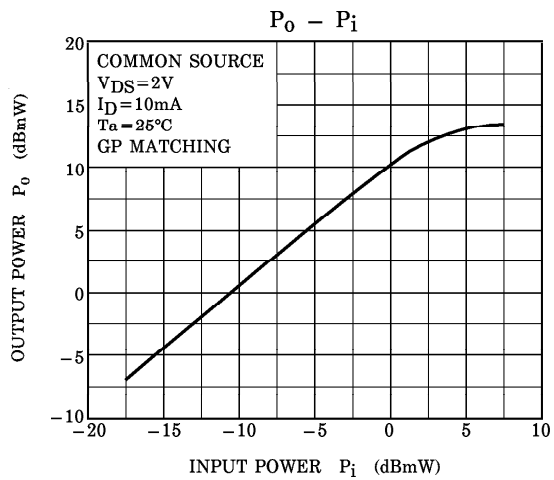
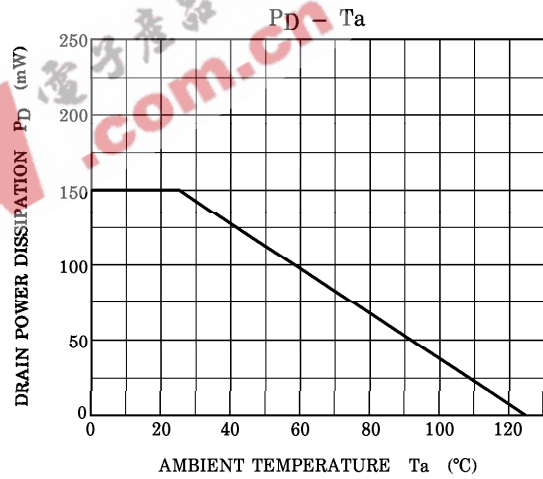
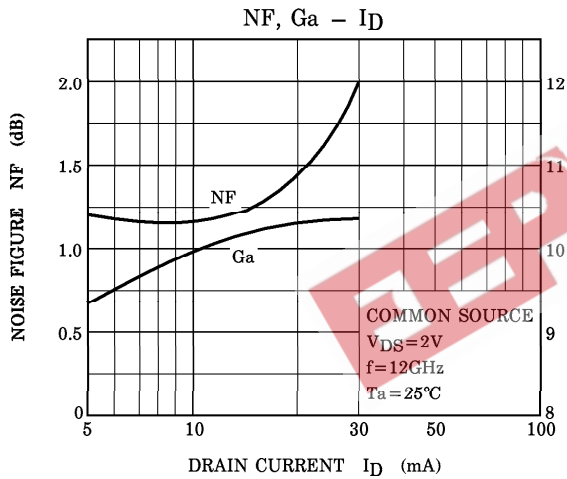
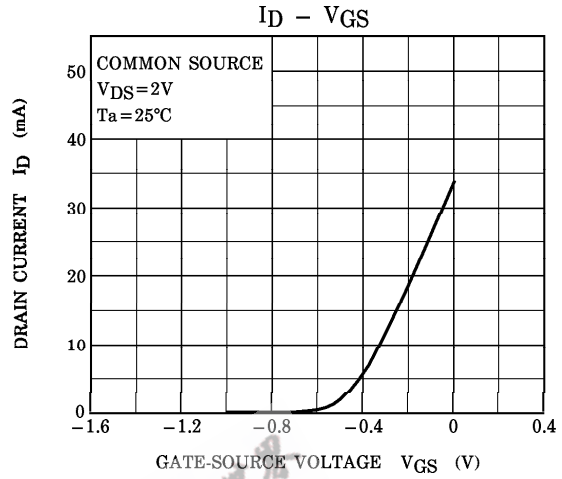
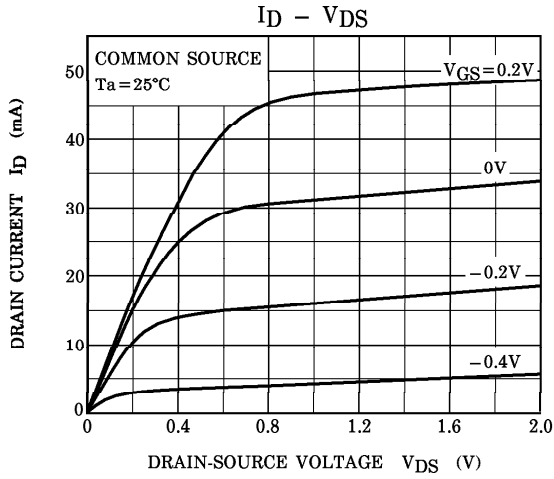

961001EAC2'

- Gallium arsenide (GaAs) is a substance used in the products described in this document. GaAs dust and fumes are toxic. Do not break, cut or pulverize the product, or use chemicals to dissolve them. When disposing of the products, follow the appropriate regulations. Do not dispose of the products with other industrial waste or with domestic garbage.
- The information contained herein is presented only as a guide for the applications of our products. No responsibility is assumed by TOSHIBA CORPORATION for any infringements of intellectual property or other rights of the third parties which may result from its use. No license is granted by implication or otherwise under any intellectual property or other rights of TOSHIBA CORPORATION or others.
- The information contained herein is subject to change without notice.

S-PARAMETER  
 COMMON SOURCE  
 ( $V_{DS}=2V$ ,  $I_D=10mA$ ,  $T_a=25^\circ C$ ,  $Z_o=50\Omega$ )

FREQ. (MHz)	INPUT (S <sub>11</sub> )		FORWARD (S <sub>21</sub> )		REVERSE (S <sub>12</sub> )		OUTPUT (S <sub>22</sub> )	
	MAG	ANG	MAG	ANG	MAG	ANG	MAG	ANG
2000	0.925	-32	5.342	147	0.045	71	0.720	-19
3000	0.843	-50	5.212	131	0.062	62	0.662	-31
4000	0.744	-70	5.000	113	0.079	48	0.597	-43
5000	0.635	-92	4.707	91	0.093	36	0.508	-55
6000	0.540	-116	4.344	77	0.099	27	0.425	-67
7000	0.474	-139	3.908	61	0.106	18	0.367	-79
8000	0.415	-163	3.540	47	0.107	7	0.306	-90
9000	0.378	167	3.205	30	0.108	-5	0.227	-101
10000	0.388	143	2.968	16	0.109	-11	0.175	-119
11000	0.415	124	2.800	3	0.110	-18	0.156	-140
12000	0.446	102	2.587	-16	0.116	-29	0.124	-168
13000	0.485	82	2.403	-31	0.117	-38	0.113	150
14000	0.529	64	2.246	-50	0.120	-50	0.135	118
15000	0.593	43	2.055	-70	0.123	-65	0.185	75
16000	0.657	25	1.781	-87	0.117	-78	0.277	46

**S<sub>11</sub>**  
COMMON SOURCE  
V<sub>DS</sub>=2V  
I<sub>D</sub>=10mA  
T<sub>a</sub>=25°C  
(UNIT : Ω)

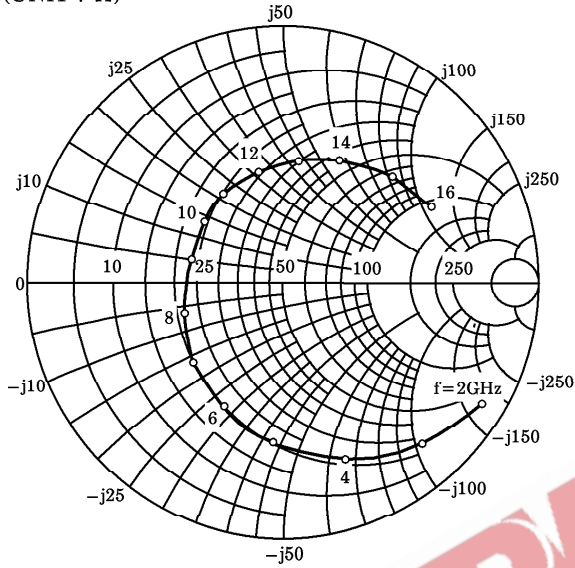

**S<sub>21</sub>**  
COMMON SOURCE  
V<sub>DS</sub>=2V  
I<sub>D</sub>=10mA  
T<sub>a</sub>=25°C

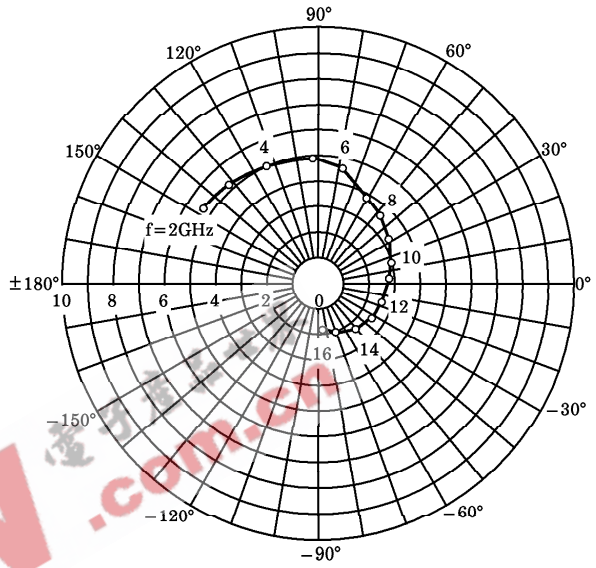

**S<sub>12</sub>**  
COMMON SOURCE  
V<sub>DS</sub>=2V  
I<sub>D</sub>=10mA  
T<sub>a</sub>=25°C

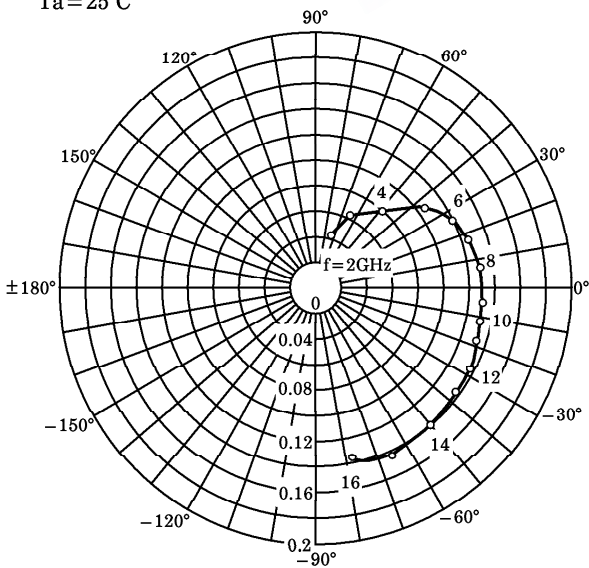

**S<sub>22</sub>**  
COMMON SOURCE  
V<sub>DS</sub>=2V  
I<sub>D</sub>=10mA  
T<sub>a</sub>=25°C  
(UNIT : Ω)

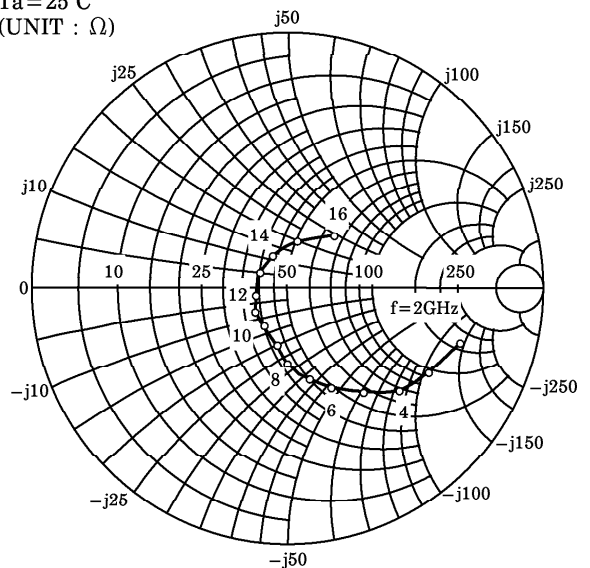

CONSTANT NOISE FIGURE

NF min = 1.20dB,  $\Gamma_{opt} = 0.14 \angle 158$ ,  $R_n = 6.1\Omega$   
@  $V_{DS} = 2V$ ,  $I_D = 10mA$ ,  $f = 12GHz$   
 $T_a = 25^\circ C$ ,  $Z_0 = 50\Omega$

