

### STANDARD RECOVERY DIODES

Stud Version

#### Features

- Diffused diode
- Wide current range
- High voltage ratings up to 1600V
- High surge current capabilities
- Stud cathode and stud anode version

250A

#### Typical Applications

- Converters
- Power supplies
- Machine tool controls
- High power drives
- Medium traction applications

#### Major Ratings and Characteristics

Parameters	70/300U(R)..D	Units
$I_{F(AV)}$	250	A
@ $T_C$	145	°C
$I_{F(RMS)}$	390	A
$I_{FSM}$ @ 50Hz	6550	A
@ 60Hz	6850	A
$I^2t$ @ 50Hz	214	KA <sup>2</sup> s
@ 60Hz	195	KA <sup>2</sup> s
$V_{RRM}$ range	1200 to 1600	V
$T_J$	- 40 to 200	°C

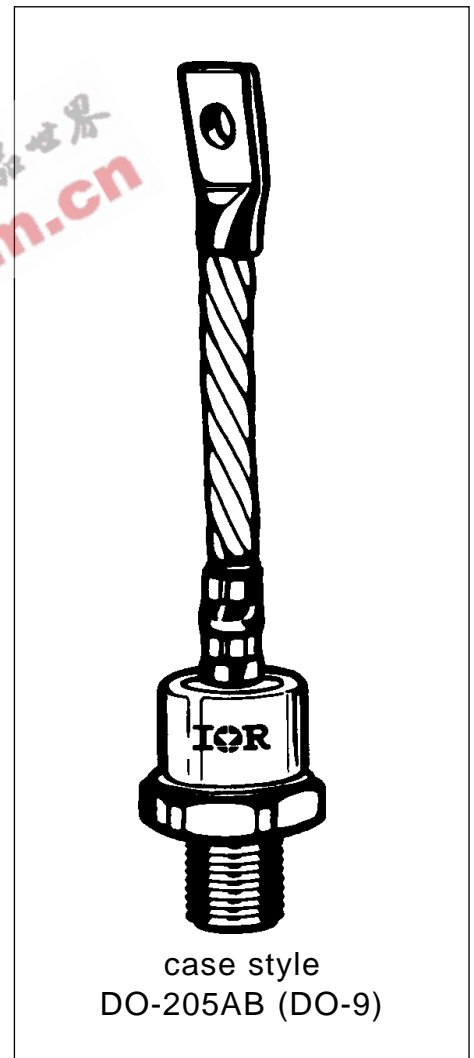

## 70/300U(R)..D Series

### ELECTRICAL SPECIFICATIONS

#### Voltage Ratings

Type number	Voltage Code	$V_{RRM}$ , maximum repetitive peak reverse voltage V	$V_{RSM}$ , maximum non-repetitive peak rev. voltage V	$I_{RRM}$ max. @ $T_J = T_J$ max. mA
70/300U(R)..D	120	1200	1300	60
	160	1600	1700	

#### Forward Conduction

Parameter	70/300U(R)..D	Units	Conditions
$I_{F(AV)}$ Max. average forward current @ Case temperature	250	A	180° conduction, half sine wave
	145	°C	
$I_{F(RMS)}$ Max. RMS forward current	390	A	DC @ 134°C case temperature
$I_{FSM}$ Max. peak, one-cycle forward, non-repetitive surge current	6550	A	t = 10ms No voltage
	6850		t = 8.3ms reapplied
	5500		t = 10ms 100% $V_{RRM}$
	5750		t = 8.3ms reapplied
$I^2t$ Maximum $I^2t$ for fusing	214	KA <sup>2</sup> s	t = 10ms No voltage
	195		t = 8.3ms reapplied
	151		t = 10ms 100% $V_{RRM}$
	138		t = 8.3ms reapplied
$I^2\sqrt{t}$ Maximum $I^2\sqrt{t}$ for fusing	2140	KA <sup>2</sup> √s	t = 0.1 to 10ms, no voltage reapplied
$V_{F(TO)1}$ Low level value of threshold voltage	0.61	V	$(16.7\% \times \pi \times I_{F(AV)} < I < \pi \times I_{F(AV)})$ , $T_J = T_J$ max.
$V_{F(TO)2}$ High level value of threshold voltage	0.83		$(I > \pi \times I_{F(AV)})$ , $T_J = T_J$ max.
$r_{f1}$ Low level value of forward slope resistance	0.75	mΩ	$(16.7\% \times \pi \times I_{F(AV)} < I < \pi \times I_{F(AV)})$ , $T_J = T_J$ max.
$r_{f2}$ High level value of forward slope resistance	0.49		$(I > \pi \times I_{F(AV)})$ , $T_J = T_J$ max.
$V_{FM}$ Max. forward voltage drop	1.30	V	$I_{pk} = 785A$ , $T_J = 25^\circ C$ , $t_p = 10ms$ sinusoidal wave

## Thermal and Mechanical Specifications

Parameter	70/300U(R)..D	Units	Conditions
$T_J$ Max. junction operating temperature range	-40 to 200	°C	
$T_{stg}$ Max. storage temperature range	-40 to 200		
$R_{thJC}$ Max. thermal resistance, junction to case	0.18	K/W	DC operation
$R_{thCS}$ Max. thermal resistance, case to heatsink	0.08		Mounting surface, smooth, flat and greased
$T$ Max. allowed mounting torque +0 -20%	37	Nm	Not lubricated threads
	28		Lubricated threads
wt Approximate weight	250	g	
Case style	DO-205AB (DO-9)		See Outline Table

 $\Delta R_{thJC}$  Conduction

(The following table shows the increment of thermal resistance  $R_{thJC}$  when devices operate at different conduction angles than DC)

Conduction angle	Sinusoidal conduction	Rectangular conduction	Units	Conditions
180°	0.020	0.015	K/W	$T_J = T_J \text{ max.}$
120°	0.024	0.025		
90°	0.031	0.034		
60°	0.045	0.047		
30°	0.077	0.077		

## Ordering Information Table

Device Code	
	<div style="display: flex; justify-content: center; align-items: center; gap: 10px;"> <div style="border: 1px solid black; padding: 2px 5px;">300</div> <div style="border: 1px solid black; padding: 2px 5px;">U</div> <div style="border: 1px solid black; padding: 2px 5px;">F</div> <div style="border: 1px solid black; padding: 2px 5px;">R</div> <div style="border: 1px solid black; padding: 2px 5px;">160</div> <div style="border: 1px solid black; padding: 2px 5px;">A</div> <div style="border: 1px solid black; padding: 2px 5px;">Y</div> <div style="border: 1px solid black; padding: 2px 5px;">P</div> <div style="border: 1px solid black; padding: 2px 5px;">D</div> </div>
	<div style="display: flex; justify-content: center; align-items: center; gap: 10px;"> <span>①</span> <span>②</span> <span>③</span> <span>④</span> <span>⑤</span> <span>⑥</span> <span>⑦</span> <span>⑧</span> <span>⑨</span> </div>
<b>1</b>	<ul style="list-style-type: none"> <li>- 300 = Standard 300U device</li> <li>70 = Standard 70U device</li> <li>302 = 300U Top Threaded version</li> <li>72 = 70U Top Threaded version</li> </ul>
<b>2</b>	- U = Essential Part Number
<b>3</b>	<ul style="list-style-type: none"> <li>- F = Flat Base (with Pinch Bolt)</li> <li>None = Normal Stud</li> </ul>
<b>4</b>	<ul style="list-style-type: none"> <li>- R = Stud Reverse Polarity (Anode to Stud)</li> <li>None = Stud Normal Polarity (Cathode to Stud)</li> </ul>
<b>5</b>	- Voltage code: Code x 10 = $V_{RRM}$ (See Voltage Ratings table)
<b>6</b>	<ul style="list-style-type: none"> <li>- A = Essential Part Number only for 300U Series</li> <li>None = 70U Series</li> </ul>
<b>7</b>	<ul style="list-style-type: none"> <li>- Y = European Lead</li> <li>None = Standard Lead</li> </ul>
<b>8</b>	- P = Forward Selection ( $1.045V < V_{FM} < 1.125V$ , $I_{FM} = 470A$ , $T_J = 25^\circ C$ )
<b>9</b>	- D = Diffused diode

# 70/300U(R)..D Series

## Outline Table

GLASS-METAL SEAL

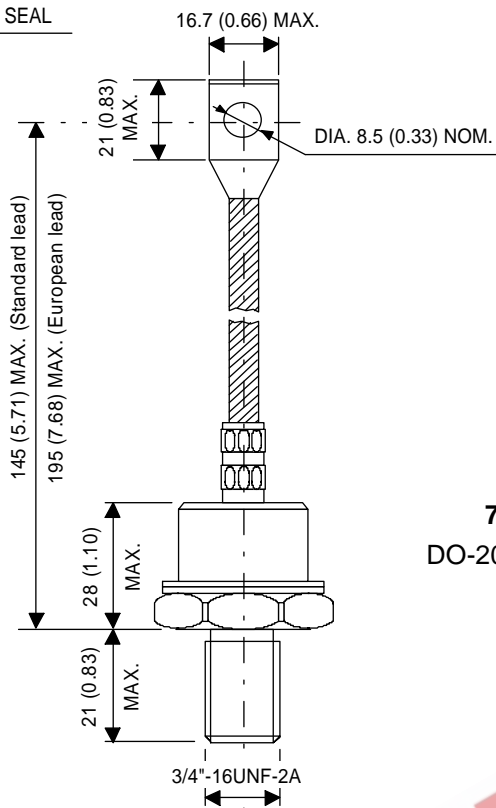

**70/300U**  
DO-205AB (DO-9)

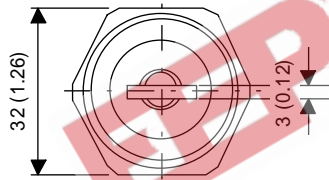

GLASS-METAL SEAL

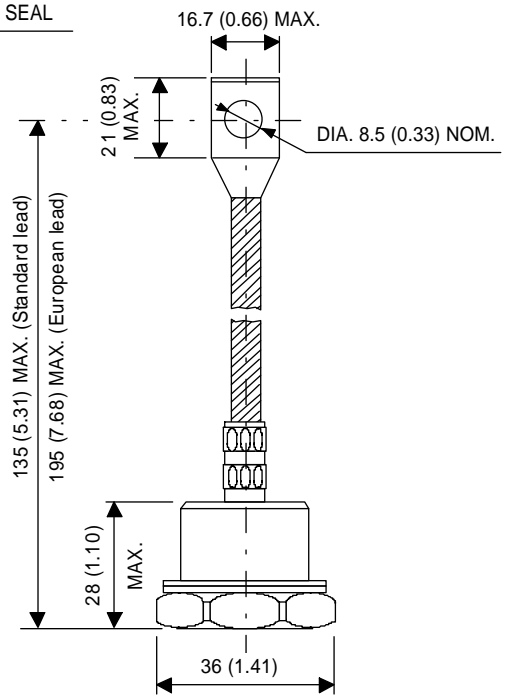

**70/300UF**  
DO-205AB (DO-9)  
Flat Base

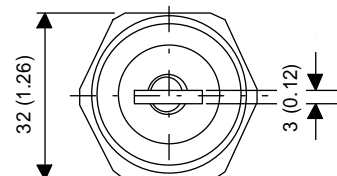

All dimensions in millimeters (inches)

Outline Table

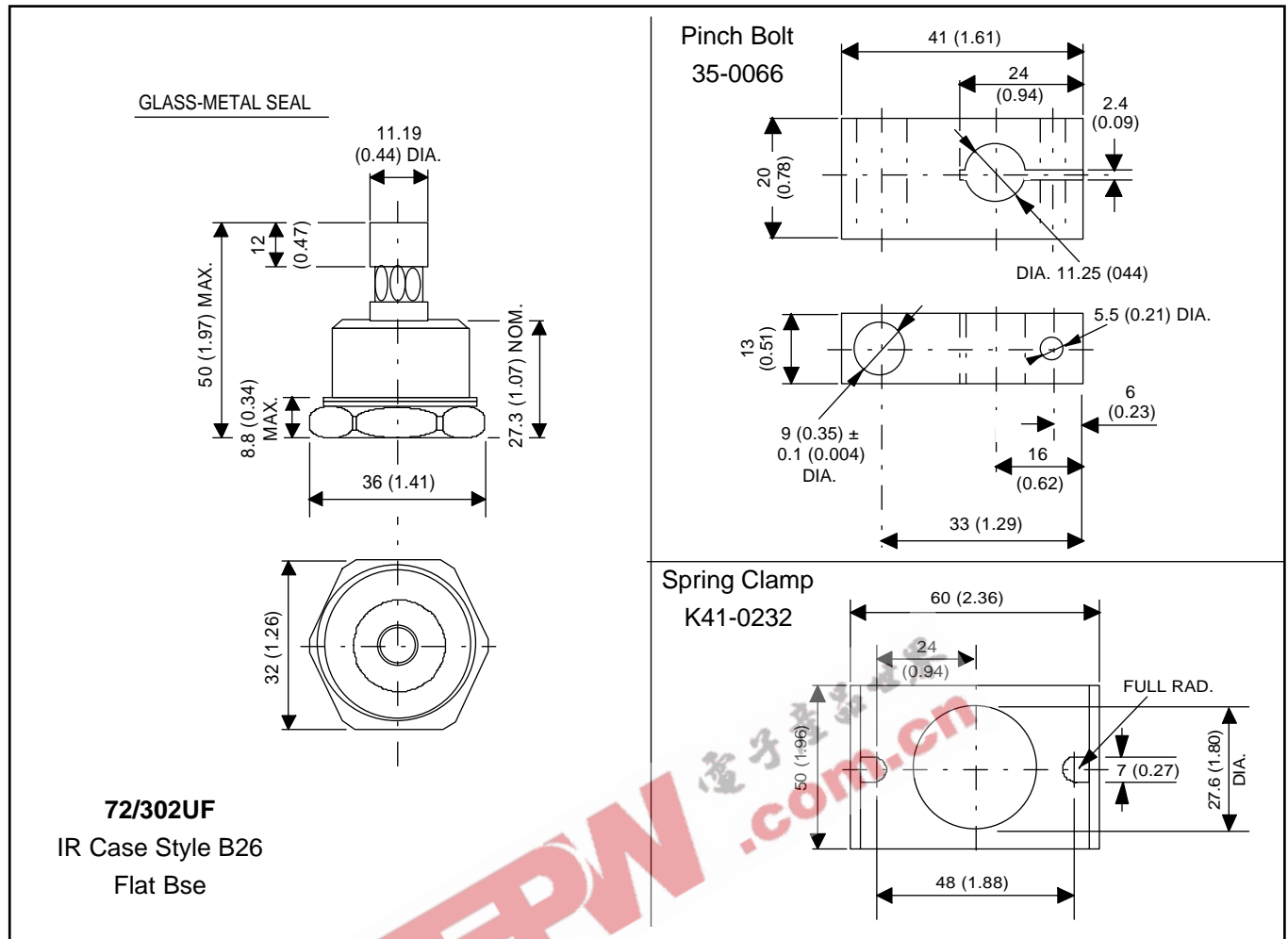

All dimensions in millimeters (inches)

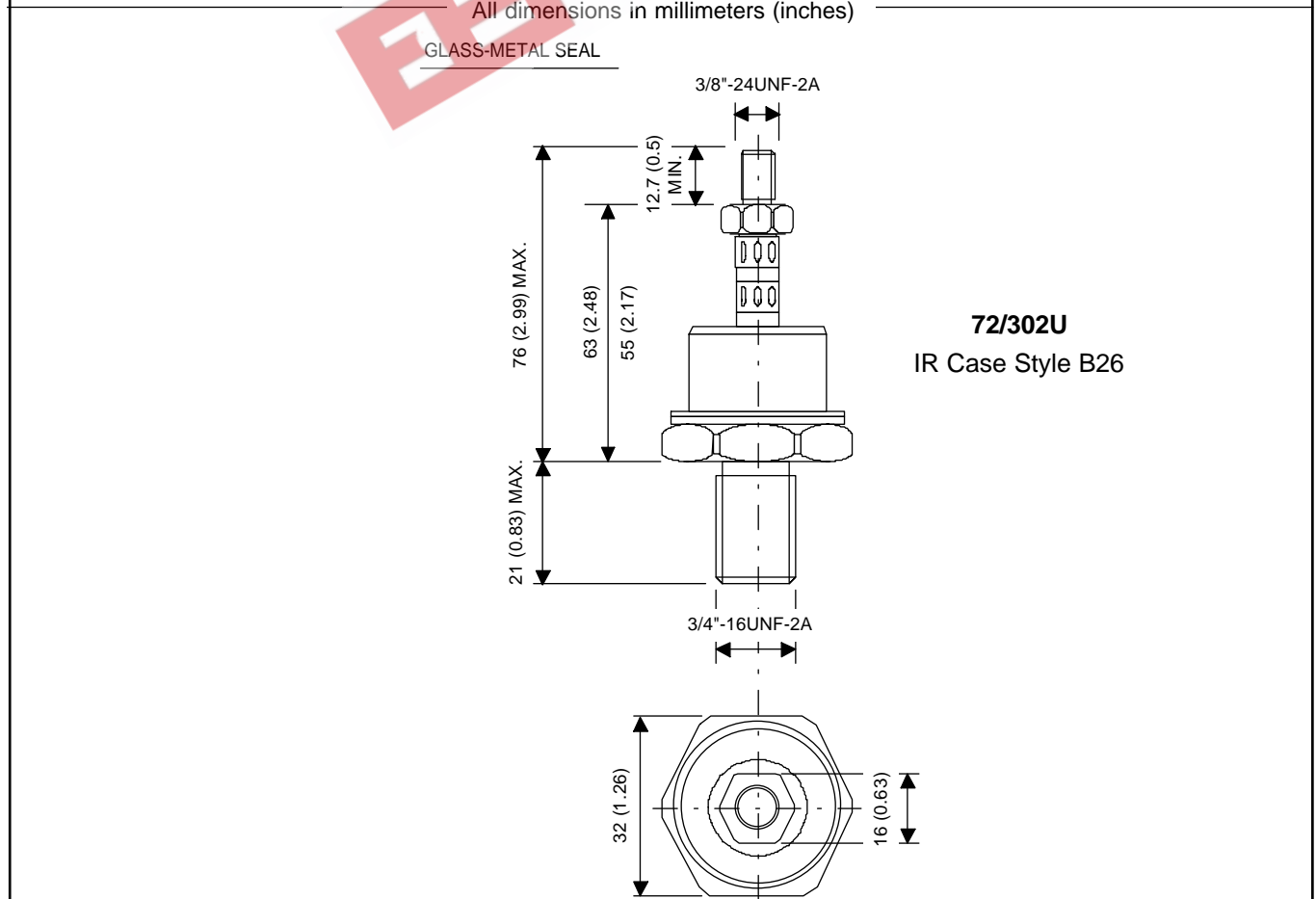

# 70/300U(R)..D Series



Fig. 1 - Current Ratings Characteristics



Fig. 2 - Current Ratings Characteristics



Fig. 3 - Forward Power Loss Characteristics



Fig. 4 - Forward Power Loss Characteristics

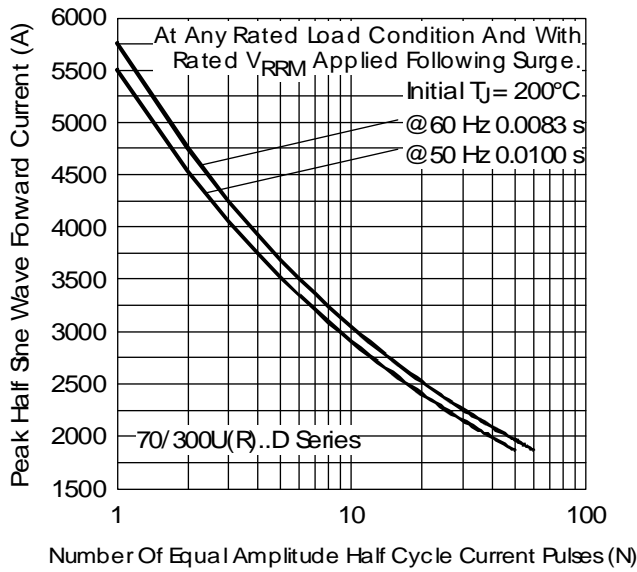

Fig. 5 - Maximum Non-Repetitive Surge Current

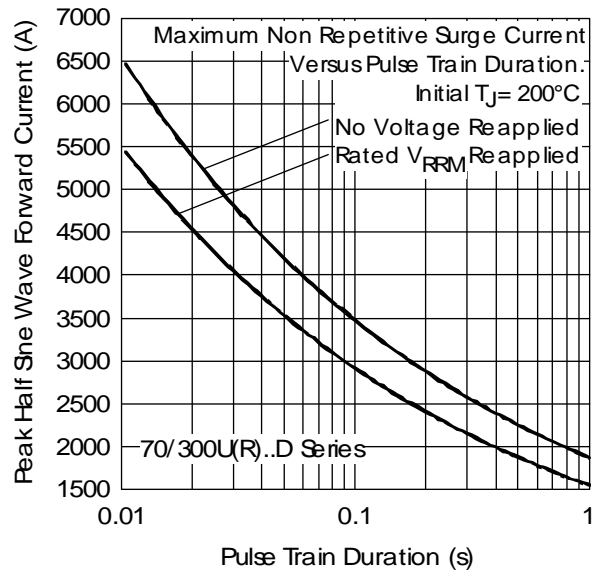

Fig. 6 - Maximum Non-Repetitive Surge Current

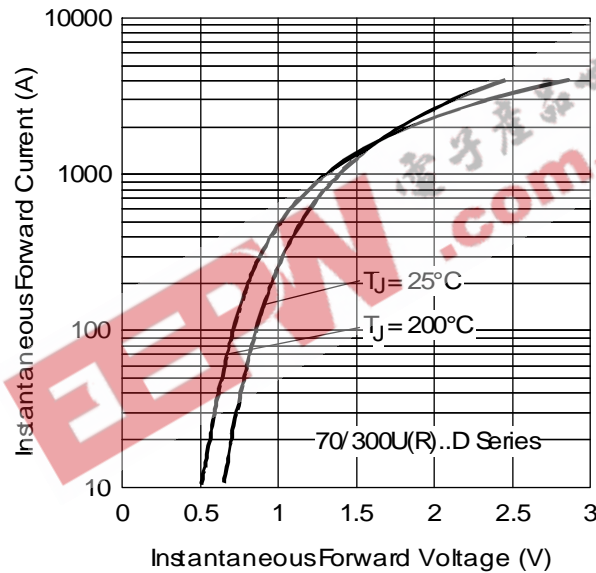

Fig. 7 - Forward Voltage Drop Characteristics

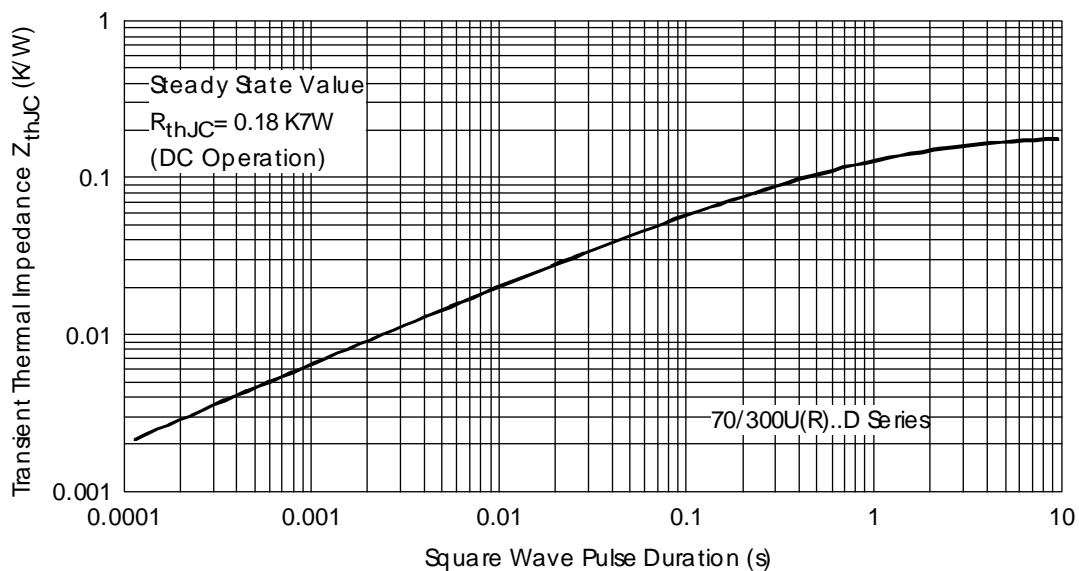

Fig. 8 - Thermal Impedance  $Z_{thJC}$  Characteristic