

**MEC CITEC**  
**POTENTIOMETERS**  
**INDUCTORS, SMDs**  
**SWITCHES, NETWORKS**  
**ENCODERS**  
**POWER COMPONENTS**

---

**Economy Trimmers**  
**TYPE 3140 SERIES**

---



---

A range of tiny single turn trimmers suited to reflow soldering and attractively priced for volume application. Alternative layouts in two and three terminal versions and low profile models (2.2mm) make this a very versatile product. All product is supplied on 12mm tape and reeled on 178mm diameter reels.

---

**MEC CITEC KEY FEATURES**

- STABLE CERMET ELEMENT
  - 0.15 W POWER RATING
  - PACKED IN 12mm STANDARD TAPE
  - ATTRACTIVELY PRICED
  - SUITED TO AUTOMATIC PLACEMENT
  - RANGE OF TERMINAL LAYOUTS
  - TEMP RANGE -25°C TO +85°C
  - GOOD VACUUM PICK UP ON HEAD
-

## SPECIFICATION

### ELECTRICAL

Resistance Range:	100R to 1M
Resistance Tolerance:	± 25%
Power Rating:	0.15W @ 70°C derating to zero at 85°C
Max. Input Voltage:	50 vdc or ac RMS max
Max. Wiper Current:	50mA
Electrical Angle, Nominal:	270° ± 10°
End Resistance, Max:	5%
Contact Resistance Variation:	5% max
Operating Temperature:	-25°C to + 85°C
Temp. Coefficient, of Resistance:	± 250 ppm/°C
Insulation Resistance, Min:	100 M Ω (DC 250V)

### DERATING CURVE

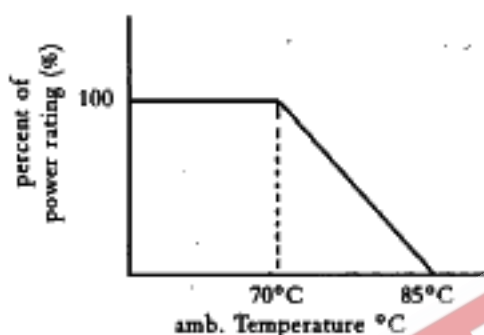

When the ambient temperature exceeds 70°C, reduce the rated power and current in accordance with the derating curve given.

### MECHANICAL

Mechanical Angle:	Continuous
Operating Torque, Max:	2.0-24.5 mNm
Solder Strength Min:	300 gF cm (3 directions)

### ENVIRONMENTAL

Humidity Exposure:	Res. Change : ± 3%
High Temperature Exposure:	Res. Change : ± 3%
Humidity Load Life:	Res. Change : ± 3%
Load Life:	Res. Change : ± 3%
Temperature Cycle:	Res. Change : ± 3%
Effect of Soldering:	Res. Change : ± 10% (10 cycle)

### ALTERNATIVE STYLES

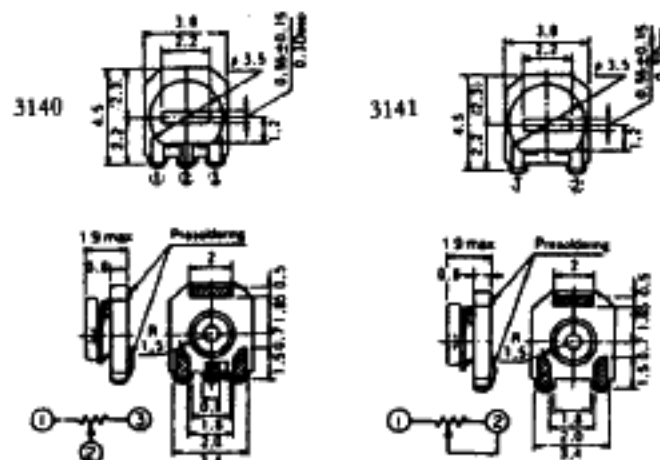

## DIMENSIONS

All dimensions are nominal and in 'mm' unless otherwise stated. Do not scale.

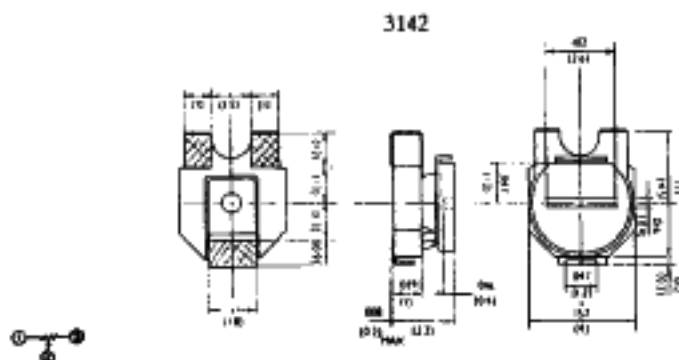

## PACKAGING (TAPE)

To meet EIA 481  
IEC 286 PT3

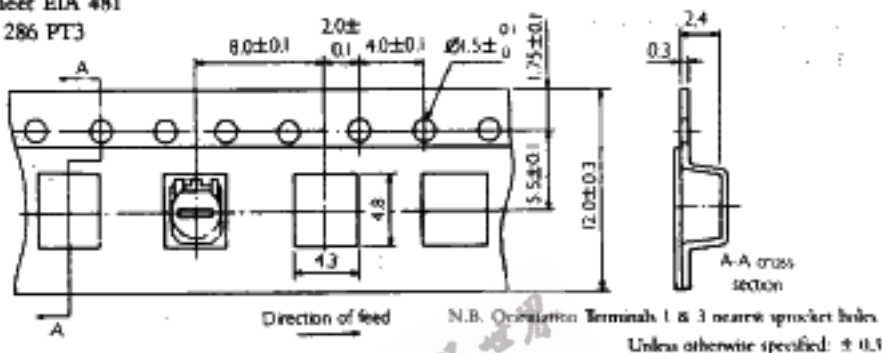

## PACKAGING (REEL)

Reel Qty  
800 pcs

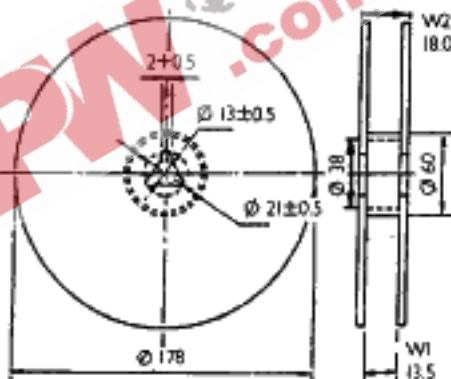

## SUBSTRATE LAYOUT

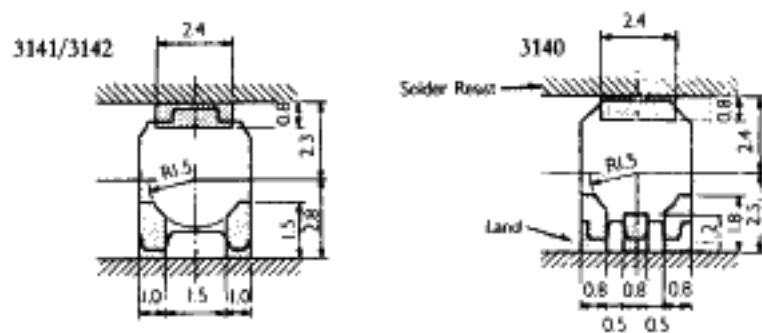

## HOW TO ORDER

COMMON PART	ORIENTATION	RESISTANCE VALUE	TOLERANCE
3140 - 3 Terminals in line 3141 - 2 Terminals in line 3142 - 3 Terminals offset	X = Terminals 1 and 3 away from sprocket holes  W = Terminals 1 and 3 towards sprocket holes	The first digits are significant figures of resistance value and the third one denotes the number of zeroes following.  Example 1 k : 102 5 k : 502 100 k : 104	P = $\pm 25\%$

## APPLICATION NOTES

### SOLDERING CONDITIONS

If soldering is repeated, please note that the allowance time is the accumulated time.  
Solder : Co-crystalized solder  
Flux : Rosin Flux

### REFLOW SOLDERING- NO PREHEAT

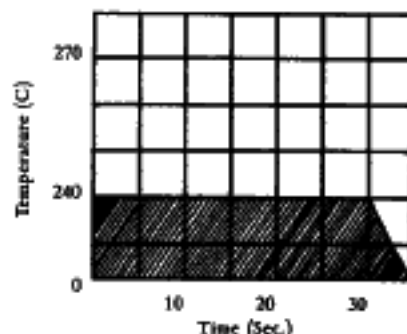

### REFLOW SOLDERING RECOMMENDED

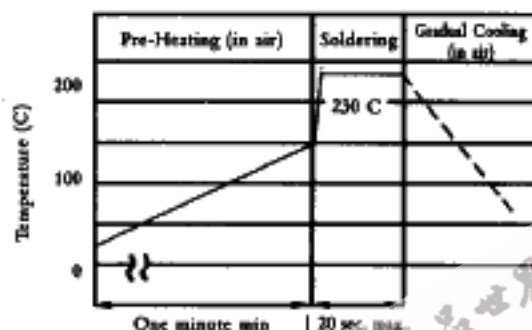

### SOLDERING WITH IRON

The following conditions must be strictly obeyed when using a soldering iron.

Soldering Iron : 20W maximum  
Tip temperature : 280°C maximum  
Soldering time : 5 seconds maximum

### CLEANING CONDITIONS

After soldering, use cleaning solvents such as chlorosen or dyefreon.

### CAUTION ON SOLDERING

The following conditions must be strictly obeyed when using a soldering iron for rework:

Soldering iron : 20W maximum  
Tip temperature : 280°C maximum (To be used only once)  
Soldering time : 3 seconds maximum

Be careful not to cause excessive force to be applied to the potentiometer after mounting.  
Reduce effects of solder temperature and time as much as possible by giving maximum allowable pre-heating.

### STORAGE

To prevent damage to the electrode, be sure to observe the following cautions for storage.

- Store in 40°C maximum ambient temperature, and 70°C maximum ambient RH.
- For maximum possible shelf life do not disturb polythene sleeve until you are ready to use potentiometers.
- Store where there are no harmful gasses containing sulphur or chlorine.

All inquires should be directed to:

Piher International Corp.  
903 Feehanville Drive.  
Mt Pleasant, IL 60056