



74ABT244

Octal Buffer/Line Driver with 3-STATE Outputs

Features

- Non-inverting buffers
- Output sink capability of 64mA, source capability of 32mA
- Guaranteed output skew
- Guaranteed multiple output switching specifications
- Output switching specified for both 50pF and 250pF loads
- Guaranteed simultaneous switching, noise level and dynamic threshold performance
- Guaranteed latchup protection
- High-impedance, glitch-free bus loading during entire power up and power down cycle
- Nondestructive, hot-insertion capability
- Disable time less than enable time to avoid bus contention

General Description

The ABT244 is an octal buffer and line driver with 3-STATE outputs designed to be employed as a memory and address driver, clock driver, or bus-oriented transmitter/receiver.

Ordering Information

| Order Number | Package Number | Package Description |
|---------------------------------|----------------|---|
| 74ABT244CSC | M20B | 20-Lead Small Outline Integrated Circuit (SOIC), JEDEC MS-013, 0.300" Wide |
| 74ABT244CSJ | M20D | 20-Lead Small Outline Package (SOP), EIAJ TYPE II, 5.3mm Wide |
| 74ABT244CMSA | MSA20 | 20-Lead Shrink Small Outline Package (SSOP), JEDEC MO-150, 5.3mm Wide |
| 74ABT244CMSAX_NL ⁽¹⁾ | MSA20 | 20-Lead Shrink Small Outline Package (SSOP), JEDEC MO-150, 5.3mm Wide |
| 74ABT244CMTC | MTC20 | 20-Lead Thin Shrink Small Outline Package (TSSOP), JEDEC MO-153, 4.4mm Wide |
| 74ABT244CMTCX_NL ⁽¹⁾ | MTC20 | 20-Lead Thin Shrink Small Outline Package (TSSOP), JEDEC MO-153, 4.4mm Wide |

Device also available in Tape and Reel. Specify by appending suffix letter "X" to the ordering number.
Pb-Free package per JEDEC J-STD-020B.

Note:

1. Device available in Tape and Reel only.

Connection Diagram

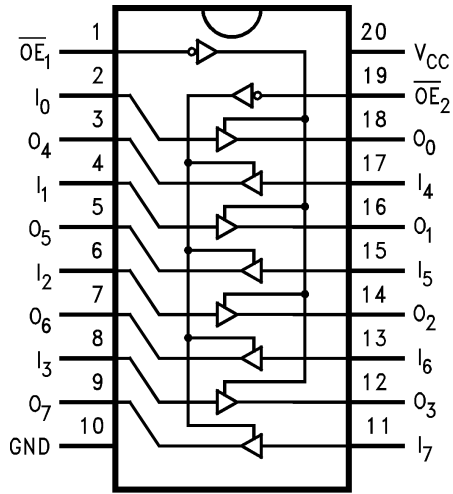

Pin Descriptions

| Pin Names | Description |
|------------------------------------|----------------------------------|
| $\overline{OE}_1, \overline{OE}_2$ | Output Enable Input (Active LOW) |
| I_0-I_7 | Inputs |
| O_0-O_7 | Outputs |

Truth Table

| \overline{OE}_1 | I_{0-3} | O_{0-3} | \overline{OE}_2 | I_{4-7} | O_{4-7} |
|-------------------|-----------|-----------|-------------------|-----------|-----------|
| H | X | Z | H | X | Z |
| L | H | H | L | H | H |
| L | L | L | L | L | L |

H = HIGH Voltage Level

L = LOW Voltage Level

X = Immaterial

Z = High Impedance



Absolute Maximum Ratings

Stresses exceeding the absolute maximum ratings may damage the device. The device may not function or be operable above the recommended operating conditions and stressing the parts to these levels is not recommended. In addition, extended exposure to stresses above the recommended operating conditions may affect device reliability. The absolute maximum ratings are stress ratings only.

| Symbol | Parameter | Rating |
|-----------|--|------------------------------------|
| T_{STG} | Storage Temperature | -65°C to +150°C |
| T_A | Ambient Temperature Under Bias | -55°C to +125°C |
| T_J | Junction Temperature Under Bias | -55°C to +150°C |
| V_{CC} | V_{CC} Pin Potential to Ground Pin | -0.5V to +7.0V |
| V_{IN} | Input Voltage ⁽²⁾ | -0.5V to +7.0V |
| I_{IN} | Input Current ⁽²⁾ | -30mA to +5.0mA |
| V_O | Voltage Applied to Any Output Disabled or Power-Off State HIGH State | -0.5V to 5.5V -0.5V to V_{CC} |
| | Current Applied to Output in LOW State (Max.) | twice the rated I_{OL} (mA) |
| | DC Latchup Source Current | -500mA |
| | Over Voltage Latchup (I/O) | 10V |

Note:

2. Either voltage limit or current limit is sufficient to protect inputs.

Recommended Operating Conditions

The Recommended Operating Conditions table defines the conditions for actual device operation. Recommended operating conditions are specified to ensure optimal performance to the datasheet specifications. Fairchild does not recommend exceeding them or designing to absolute maximum ratings.

| Symbol | Parameter | Rating |
|-----------------------|------------------------------|----------------|
| T_A | Free Air Ambient Temperature | -40°C to +85°C |
| V_{CC} | Supply Voltage | +4.5V to +5.5V |
| $\Delta V / \Delta t$ | Minimum Input Edge Rate | |
| | Data Input | 50mV/ns |
| | Enable Input | 20mV/ns |

DC Electrical Characteristics

| Symbol | Parameter | | V _{CC} | Conditions | Min. | Typ. | Max. | Units |
|------------------|--|-----------------|-----------------|---|------|------|------|--------|
| V _{IH} | Input HIGH Voltage | | | Recognized HIGH Signal | 2.0 | | | V |
| V _{IL} | Input LOW Voltage | | | Recognized LOW Signal | | | 0.8 | V |
| V _{CD} | Input Clamp Diode Voltage | | Min. | I _{IN} = -18mA | | | -1.2 | V |
| V _{OH} | Output HIGH Voltage | | Min. | I _{OH} = -3mA | 2.5 | | | V |
| | | | | I _{OH} = -32mA | 2.0 | | | |
| V _{OL} | Output LOW Voltage | | | I _{OL} = 64mA | | | 0.55 | V |
| I _{IH} | Input HIGH Current | | Max. | V _{IN} = 2.7V ⁽⁴⁾ | | | 1 | μA |
| | | | | V _{IN} = V _{CC} | | | 1 | |
| I _{BVI} | Input HIGH Current Breakdown Test | | Max. | V _{IN} = 7.0V | | | 7 | μA |
| I _{IL} | Input LOW Current | | Max. | V _{IN} = 0.5V ⁽⁴⁾ | | | -1 | μA |
| | | | | V _{IN} = 0.0V | | | -1 | |
| V _{ID} | Input Leakage Test | | 0.0 | I _{ID} = 1.9μA, All Other Pins Grounded | 4.75 | | | V |
| I _{OZH} | Output Leakage Current | | 0-5.5V | V _{OUT} = 2.7V, $\overline{OE}_n = 2.0V$ | | | 10 | μA |
| I _{OZL} | Output Leakage Current | | 0-5.5V | V _{OUT} = 0.5V, $\overline{OE}_n = 2.0V$ | | | -10 | μA |
| I _{OS} | Output Short-Circuit Current | | Max. | V _{OUT} = 0.0V | -100 | | -275 | mA |
| I _{CEX} | Output High Leakage Current | | Max. | V _{OUT} = V _{CC} | | | 50 | μA |
| I _{ZZ} | Bus Drainage Test | | 0.0 | V _{OUT} = 5.5V, All Others GND | | | 100 | μA |
| I _{CCH} | Power Supply Current | | Max. | All Outputs HIGH | | | 50 | μA |
| I _{CCL} | Power Supply Current | | Max. | All Outputs LOW | | | 30 | mA |
| I _{CCZ} | Power Supply Current | | Max. | $\overline{OE}_n = V_{CC}$, All Others at V _{CC} or Ground | | | 50 | μA |
| I _{CC1} | Additional I _{CC} /Input | Outputs Enabled | Max. | V _I = V _{CC} - 2.1V | | | 2.5 | mA |
| | | Outputs 3-STATE | | Enable Input V _I = V _{CC} - 2.1V | | | 2.5 | |
| | | Outputs 3-STATE | | Data Input V _I = V _{CC} - 2.1V, All Others at V _{CC} or Ground | | | 50 | |
| I _{CCD} | Dynamic I _{CC} No Load ⁽⁴⁾ | | Max. | Outputs OPEN, $\overline{OE}_n = GND$ ⁽³⁾ , One-Bit Toggling, 50% Duty Cycle | | | 0.1 | mA/MHz |

Notes:

- For 8-bit toggling, I_{CCD} < 0.8mA/MHz.
- Guaranteed, but not tested.

DC Electrical Characteristics

SOIC package.

| Symbol | Parameter | V _{CC} | Conditions C _L = 50pF, R _L = 500Ω | Min. | Typ. | Max. | Units |
|------------------|--|-----------------|---|------|------|------|-------|
| V _{OLP} | Quiet Output Maximum Dynamic V _{OL} | 5.0 | T _A = 25°C ⁽⁵⁾ | | 0.5 | 0.8 | V |
| V _{OLV} | Quiet Output Minimum Dynamic V _{OL} | 5.0 | T _A = 25°C ⁽⁵⁾ | -1.3 | -0.8 | | V |
| V _{OHV} | Minimum HIGH Level Dynamic Output Voltage | 5.0 | T _A = 25°C ⁽⁷⁾ | 2.7 | 3.1 | | V |
| V _{IHD} | Minimum HIGH Level Dynamic Input Voltage | 5.0 | T _A = 25°C ⁽⁶⁾ | 2.0 | 1.5 | | V |
| V _{ILD} | Maximum LOW Level Dynamic Input Voltage | 5.0 | T _A = 25°C ⁽⁶⁾ | | 1.1 | 0.8 | V |

Notes:

- Max number of outputs defined as (n). n – 1 data inputs are driven 0V to 3V. One output at LOW. Guaranteed, but not tested.
- Max number of data inputs (n) switching. n – 1 inputs switching 0V to 3V. Input-under-test switching: 3V to threshold (V_{ILD}), 0V to threshold (V_{IHD}). Guaranteed, but not tested.
- Max number of outputs defined as (n). n – 1 data inputs are driven 0V to 3V. One output HIGH. Guaranteed, but not tested.

AC Electrical Characteristics

SOIC and SSOP package.

| Symbol | Parameter | T _A = +25°C, V _{CC} = +5V, C _L = 50pF | | | T _A = -55°C to +125°C, V _{CC} = 4.5V–5.5V, C _L = 50pF | | T _A = -40°C to +85°C, V _{CC} = 4.5V–5.5V, C _L = 50pF | | Units |
|------------------|--------------------------------------|--|------|------|--|------|---|------|-------|
| | | Min. | Typ. | Max. | Min. | Max. | Min. | Max. | |
| t _{PLH} | Propagation Delay Data to Outputs | 1.0 | 2.5 | 3.6 | 1.0 | 5.3 | 1.0 | 3.6 | ns |
| t _{PHL} | | 1.0 | 2.3 | 3.6 | 1.0 | 5.0 | 1.0 | 3.6 | |
| t _{PZH} | Output Enable Time | 1.5 | 3.5 | 6.0 | 0.8 | 6.5 | 1.5 | 6.0 | ns |
| t _{PZL} | | 1.5 | 3.6 | 6.0 | 1.2 | 7.9 | 1.5 | 6.0 | |
| t _{PHZ} | Output Disable Time | 1.7 | 3.5 | 5.6 | 1.2 | 7.6 | 1.7 | 5.6 | ns |
| t _{PLZ} | | 1.7 | 3.3 | 5.6 | 1.0 | 7.9 | 1.7 | 5.6 | |

Extended AC Electrical Characteristics

SOIC package.

| Symbol | Parameter | $T_A = -40^\circ\text{C to } +85^\circ\text{C}$, $V_{CC} = 4.5\text{V} - 5.5\text{V}$, $C_L = 50\text{pF}$, 8 Outputs Switching ⁽⁸⁾ | | | $T_A = -40^\circ\text{C to } +85^\circ\text{C}$, $V_{CC} = 4.5\text{V} - 5.5\text{V}$, $C_L = 250\text{pF}$, 1 Output Switching ⁽⁹⁾ | | $T_A = -40^\circ\text{C to } +85^\circ\text{C}$, $V_{CC} = 4.5\text{V} - 5.5\text{V}$, $C_L = 250\text{pF}$, 8 Outputs Switching ⁽¹⁰⁾ | | Units |
|---------------------|---------------------------------------|---|------|------|---|------|---|------|-------|
| | | Min. | Typ. | Max. | Min. | Max. | Min. | Max. | |
| f_{TOGGLE} | Max Toggle Frequency | | 100 | | | | | | MHz |
| t_{PLH} | Propagation Delay, Data to Outputs | 1.5 | | 5.0 | 1.5 | 6.0 | 2.5 | 8.5 | ns |
| t_{PHL} | | 1.5 | | 5.0 | 1.5 | 6.0 | 2.5 | 8.5 | |
| t_{PZH} | Output Enable Time | 1.5 | | 6.5 | 2.5 | 7.5 | 2.5 | 10.0 | ns |
| t_{PZL} | | 1.5 | | 6.5 | 2.5 | 7.5 | 2.5 | 12.0 | |
| t_{PHZ} | Output Disable Time | 1.0 | | 5.6 | (11) | | (11) | | ns |
| t_{PLZ} | | 1.0 | | 5.6 | | | | | |

Notes:

8. This specification is guaranteed but not tested. The limits apply to propagation delays for all paths described switching in phase (i.e., all LOW-to-HIGH, HIGH-to-LOW, etc.).
9. This specification is guaranteed but not tested. The limits represent propagation delay with 250pF load capacitors in place of the 50pF load capacitors in the standard AC load. This specification pertains to single output switching only.
10. This specification is guaranteed but not tested. The limits represent propagation delays for all paths described switching in phase (i.e., all LOW-to-HIGH, HIGH-to-LOW, etc.) with 250pF load capacitors in place of the 50pF load capacitors in the standard AC load.
11. The 3-STATE delays are dominated by the RC network (500Ω, 250pF) on the output and have been excluded from the datasheet.

Skew

| Symbol | Parameter | $T_A = -40^\circ\text{C to } +85^\circ\text{C},$ $V_{CC} = 4.5\text{V}–5.5\text{V},$ $C_L = 50\text{pF},$ 8 Outputs Switching ⁽¹⁴⁾ | $T_A = -40^\circ\text{C to } +85^\circ\text{C},$ $V_{CC} = 4.5\text{V}–5.5\text{V},$ $C_L = 250\text{pF},$ 8 Outputs Switching ⁽¹⁵⁾ | Units |
|-------------------|---|--|---|-------|
| | | Max. | Max. | |
| $t_{OSHL}^{(12)}$ | Pin to Pin Skew, HL Transitions | 0.8 | 1.8 | ns |
| $t_{OSLH}^{(12)}$ | Pin to Pin Skew, LH Transitions | 0.8 | 1.8 | ns |
| $t_{PS}^{(16)}$ | Duty Cycle, LH–HL Skew | 1.0 | 2.5 | ns |
| $t_{OST}^{(12)}$ | Pin to Pin Skew, LH/HL Transitions | 1.0 | 2.5 | ns |
| $t_{PV}^{(13)}$ | Device to Device Skew, LH/HL Transitions | 1.5 | 3.0 | ns |

Notes:

- Skew is defined as the absolute value of the difference between the actual propagation delays for any two separate outputs of the same device. The specification applies to any outputs switching HIGH-to-LOW (t_{OSHL}), LOW-to-HIGH (t_{OSLH}), or any combination switching LOW-to-HIGH and/or HIGH-to-LOW (t_{OST}). The specification is guaranteed but not tested.
- Propagation delay variation for a given set of conditions (i.e., temperature and V_{CC}) from device to device. This specification is guaranteed but not tested.
- This specification is guaranteed but not tested. The limits apply to propagation delays for all paths described switching in phase (i.e., all LOW-to-HIGH, HIGH-to-LOW, etc.)
- These specifications guaranteed but not tested. The limits represent propagation delays with 250pF load capacitors in place of the 50pF load capacitors in the standard AC load.
- This describes the difference between the delay of the LOW-to-HIGH and the HIGH-to-LOW transition on the same pin. It is measured across all the outputs (drivers) on the same chip, the worst (largest delta) number is the guaranteed specification. This specification is guaranteed but not tested.

Capacitance

| Symbol | Parameter | Conditions $T_A = 25^\circ\text{C}$ | Typ. | Units |
|------------------|--------------------|--|------|-------|
| C_{IN} | Input Capacitance | $V_{CC} = 0\text{V}$ | 5.0 | pF |
| $C_{OUT}^{(17)}$ | Output Capacitance | $V_{CC} = 5.0\text{V}$ | 9.0 | pF |

Note:

- C_{OUT} is measured at frequency $f = 1\text{MHz}$, per MIL-STD-883, Method 3012.

AC Loading

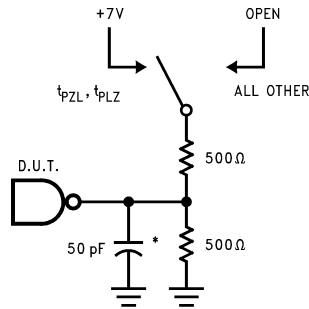

*Includes jig and probe capacitance

Figure 1. Standard AC Test Load

AC Waveforms

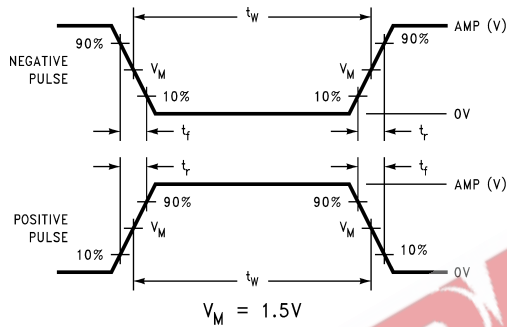

Figure 2. Test Input Signal Levels

| Amplitude | Rep. Rate | t_w | t_r | t_f |
|-----------|-----------|-------|-------|-------|
| 3.0V | 1 MHz | 500ns | 2.5ns | 2.5ns |

Figure 3. Test Input Signal Requirements

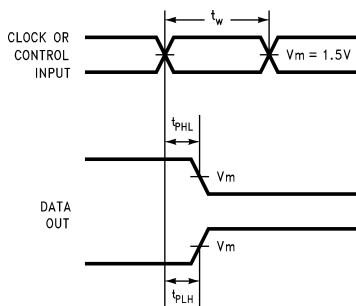

Figure 4. Propagation Delay, Pulse Width Waveforms

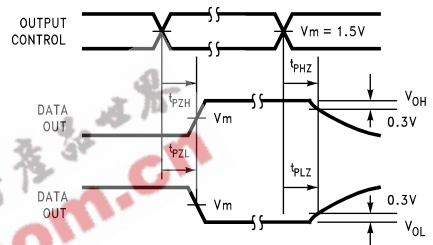

Figure 5. 3-STATE Output HIGH and LOW Enable and Disable Times

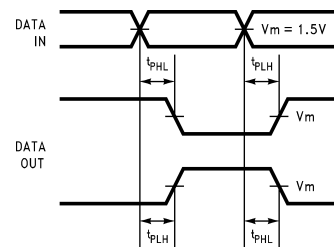

Figure 6. Propagation Delay Waveforms for Inverting and Non-Inverting Functions

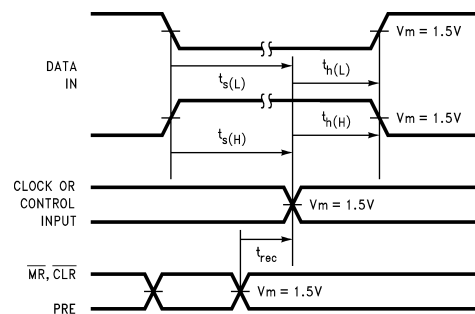

Figure 7. Setup Time, Hold Time and Recovery Time Waveforms

Physical Dimensions

Dimensions are in inches (millimeters) unless otherwise noted.

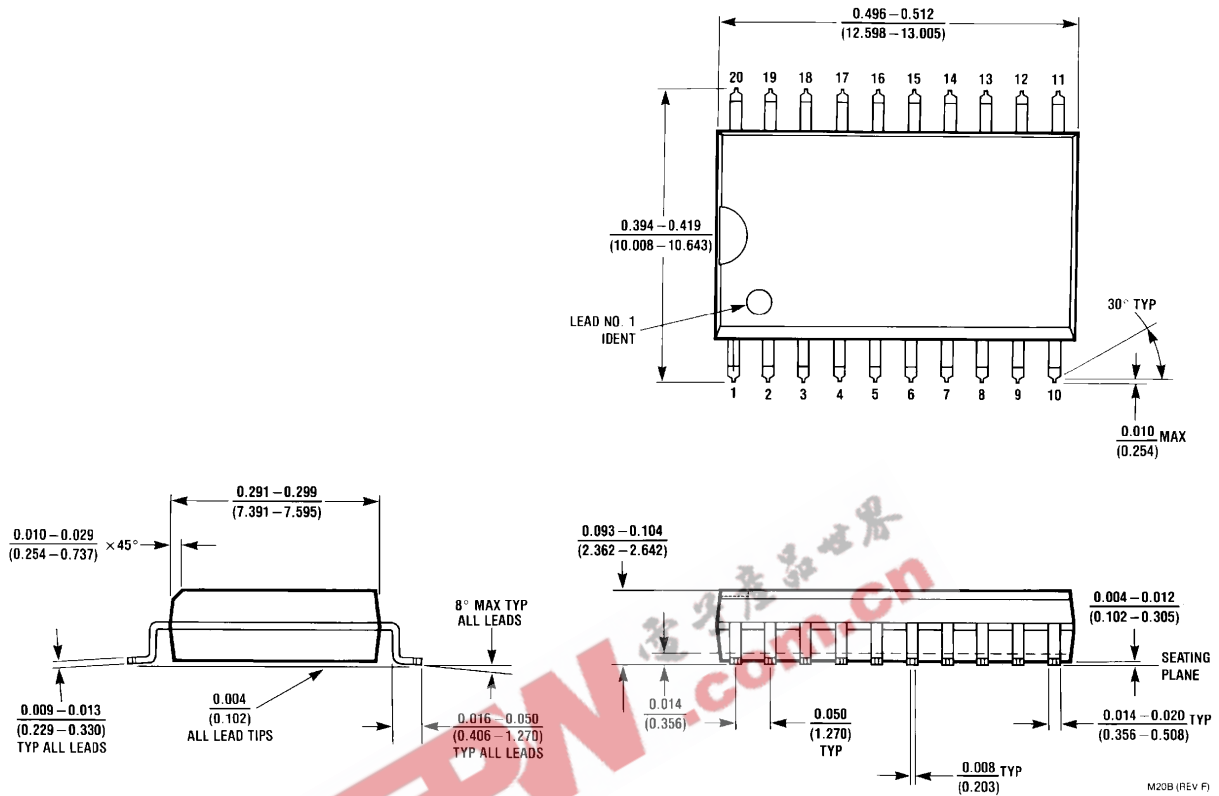
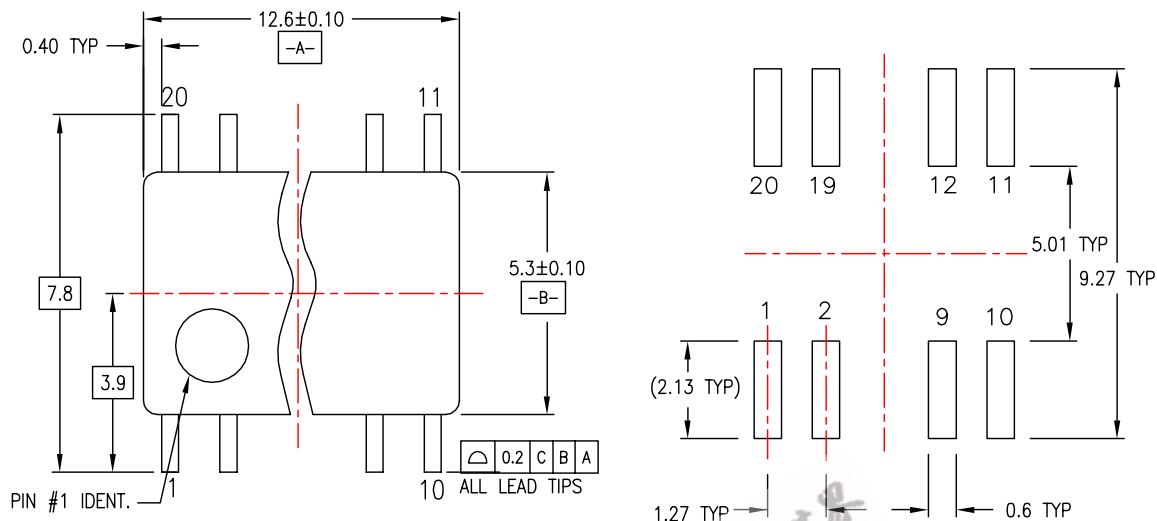

Figure 8. 20-Lead Small Outline Integrated Circuit (SOIC), JEDEC MS-013, 0.300" Wide Package Number M20B

Physical Dimensions (Continued)

Dimensions are in millimeters unless otherwise noted.



LAND PATTERN RECOMMENDATION

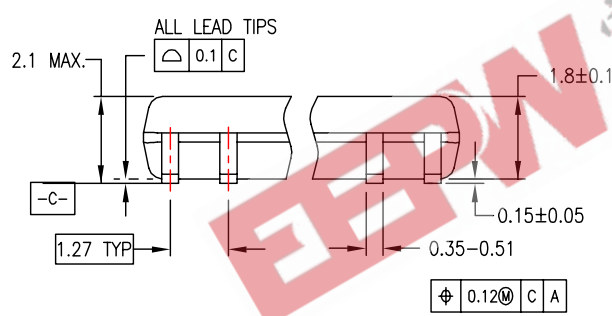

DIMENSIONS ARE IN MILLIMETERS

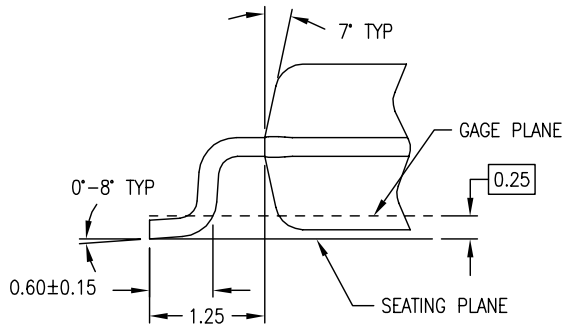
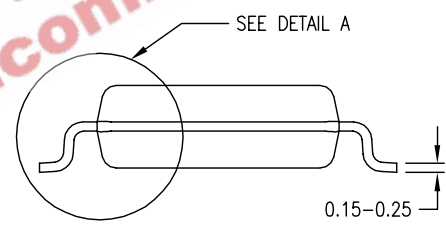

DETAIL A

- NOTES:
- A. CONFORMS TO EIAJ EDR-7320 REGISTRATION, ESTABLISHED IN DECEMBER, 1998.
 - B. DIMENSIONS ARE IN MILLIMETERS.
 - C. DIMENSIONS ARE EXCLUSIVE OF BURRS, MOLD FLASH, AND TIE BAR EXTRUSIONS.

M20DREV C

Figure 9. 20-Lead Small Outline Package (SOP), EIAJ TYPE II, 5.3mm Wide Package Number M20D

Physical Dimensions (Continued)

Dimensions are in millimeters unless otherwise noted.

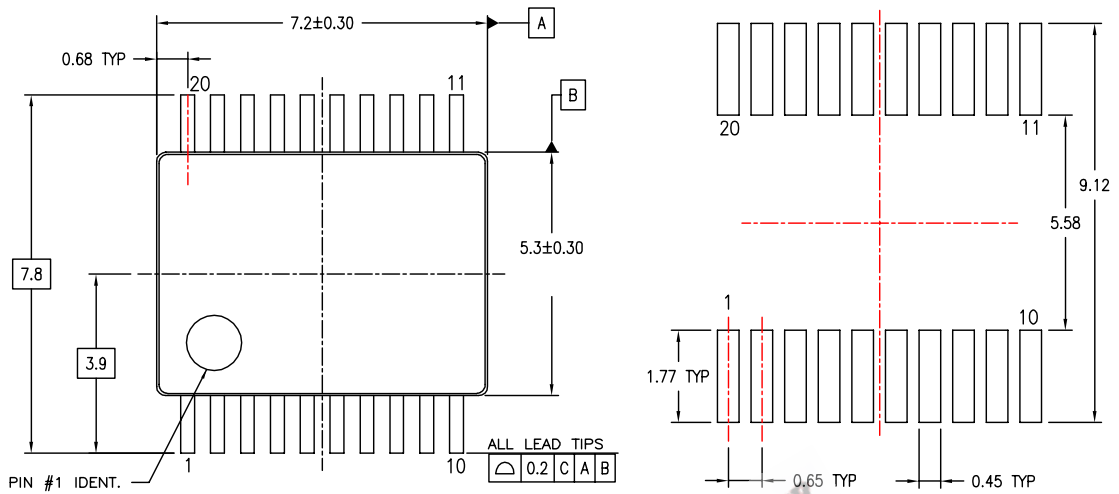

| | | | | |
|---------------|--------------|---|---|---|
| ALL LEAD TIPS | Δ 0.2 | C | A | B |
|---------------|--------------|---|---|---|

LAND PATTERN RECOMMENDATIONS

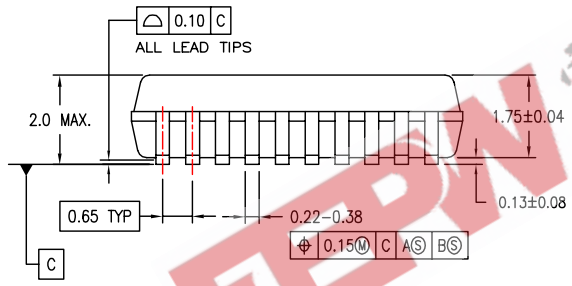

DIMENSIONS ARE IN MILLIMETERS

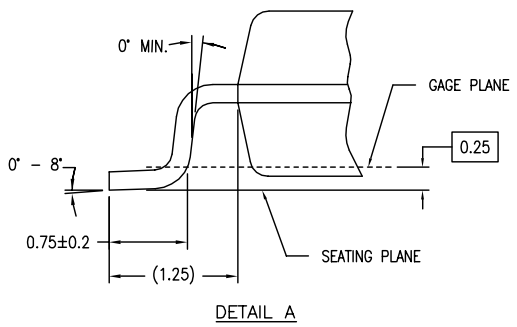
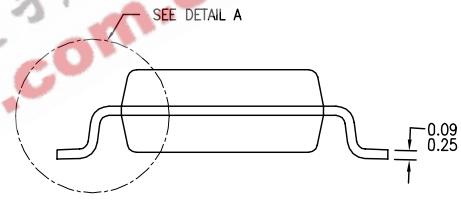

NOTES:

- A. CONFORMS TO JEDEC REGISTRATION MO-150, VARIATION AE, DATE 1/94.
- B. DIMENSIONS ARE IN MILLIMETERS.
- C. DIMENSIONS ARE EXCLUSIVE OF BURRS, MOLD FLASH, AND TIE BAR EXTRUSIONS.
- D. DIMENSIONS AND TOLERANCES PER ASME Y14.5M - 1994.

MSA20REVB

Figure 10. 20-Lead Shrink Small Outline Package (SSOP), JEDEC MO-150, 5.3mm Wide Package Number MSA20



TRADEMARKS

The following are registered and unregistered trademarks Fairchild Semiconductor owns or is authorized to use and is not intended to be an exhaustive list of all such trademarks.

| | | | |
|--------------------------------------|--------------------|----------------------------|-----------------|
| ACEx® | HiSeC™ | Programmable Active Droop™ | TinyLogic® |
| Across the board. Around the world.™ | i-Lo™ | QFET® | TINYOPTO™ |
| ActiveArray™ | ImpliedDisconnect™ | QS™ | TinyPower™ |
| Bottomless™ | IntelliMAX™ | QT Optoelectronics™ | TinyWire™ |
| Build it Now™ | ISOPLANAR™ | Quiet Series™ | TruTranslation™ |
| CoolFET™ | MICROCOUPLER™ | RapidConfigure™ | μSerDes™ |
| CROSSVOLT™ | MicroPak™ | RapidConnect™ | UHC® |
| CTL™ | MICROWIRE™ | ScalarPump™ | UniFET™ |
| Current Transfer Logic™ | MSX™ | SMART START™ | VCX™ |
| DOME™ | MSXPro™ | SPM® | Wire™ |
| E ² CMOS™ | OCX™ | STEALTH™ | |
| EcoSPARK® | OCXPro™ | SuperFET™ | |
| EnSigna™ | OPTOLOGIC® | SuperSOT™-3 | |
| FACT Quiet Series™ | OPTOPLANAR® | SuperSOT™-6 | |
| FACT® | PACMAN™ | SuperSOT™-8 | |
| FAST® | POP™ | SyncFET™ | |
| FASTr™ | Power220® | TCM™ | |
| FPS™ | Power247® | The Power Franchise® | |
| FRFET® | PowerEdge™ | TinyBoost™ | |
| GlobalOptoisolator™ | PowerSaver™ | TinyBuck™ | |
| GTO™ | PowerTrench® | | |

DISCLAIMER

FAIRCHILD SEMICONDUCTOR RESERVES THE RIGHT TO MAKE CHANGES WITHOUT FURTHER NOTICE TO ANY PRODUCTS HEREIN TO IMPROVE RELIABILITY, FUNCTION OR DESIGN. FAIRCHILD DOES NOT ASSUME ANY LIABILITY ARISING OUT OF THE APPLICATION OR USE OF ANY PRODUCT OR CIRCUIT DESCRIBED HEREIN; NEITHER DOES IT CONVEY ANY LICENSE UNDER ITS PATENT RIGHTS, NOR THE RIGHTS OF OTHERS. THESE SPECIFICATIONS DO NOT EXPAND THE TERMS OF FAIRCHILD'S WORLDWIDE TERMS AND CONDITIONS, SPECIFICALLY THE WARRANTY THEREIN, WHICH COVERS THESE PRODUCTS.

LIFE SUPPORT POLICY

FAIRCHILD'S PRODUCTS ARE NOT AUTHORIZED FOR USE AS CRITICAL COMPONENTS IN LIFE SUPPORT DEVICES OR SYSTEMS WITHOUT THE EXPRESS WRITTEN APPROVAL OF FAIRCHILD SEMICONDUCTOR CORPORATION.

As used herein:

1. Life support devices or systems are devices or systems which, (a) are intended for surgical implant into the body or (b) support or sustain life, and (c) whose failure to perform when properly used in accordance with instructions for use provided in the labeling, can be reasonably expected to result in a significant injury of the user.
2. A critical component in any component of a life support, device, or system whose failure to perform can be reasonably expected to cause the failure of the life support device or system, or to affect its safety or effectiveness.

PRODUCT STATUS DEFINITIONS

Definition of Terms

| Datasheet Identification | Product Status | Definition |
|--------------------------|------------------------|--|
| Advance Information | Formative or In Design | This datasheet contains the design specifications for product development. Specifications may change in any manner without notice. |
| Preliminary | First Production | This datasheet contains preliminary data; supplementary data will be published at a later date. Fairchild Semiconductor reserves the right to make changes at any time without notice to improve design. |
| No Identification Needed | Full Production | This datasheet contains final specifications. Fairchild Semiconductor reserves the right to make changes at any time without notice to improve design. |
| Obsolete | Not In Production | This datasheet contains specifications on a product that has been discontinued by Fairchild Semiconductor. The datasheet is printed for reference information only. |

Rev. I24