

74ABT16373 16-Bit Transparent D-Type Latch with 3-STATE Outputs

General Description

The ABT16373 contains sixteen non-inverting latches with 3-STATE outputs and is intended for bus oriented applications. The device is byte controlled. The flip-flops appear transparent to the data when the Latch Enable (LE) is HIGH. When LE is LOW, the data that meets the setup time is latched. Data appears on the bus when the Output Enable (\overline{OE}) is LOW. When \overline{OE} is HIGH, the outputs are in high Z state.

Features

- Separate control logic for each byte
- 16-bit version of the ABT373
- High impedance glitch free bus loading during entire power up and power down cycle
- Non-destructive hot insertion capability
- Guaranteed latch-up protection

Ordering Code:

Order Number	Package Number	Package Description
74ABT16373CSSC	MS48A	48-Lead Small Shrink Outline Package (SSOP), JEDEC MO-118, 0.300" Wide
74ABT16373CMTD	MTD48	48-Lead Thin Shrink Small Outline Package (TSSOP), JEDEC MO-153, 6.1mm Wide

Devices also available in Tape and Reel. Specify by appending suffix letter "X" to the ordering code.

Logic Symbol



Connection Diagram

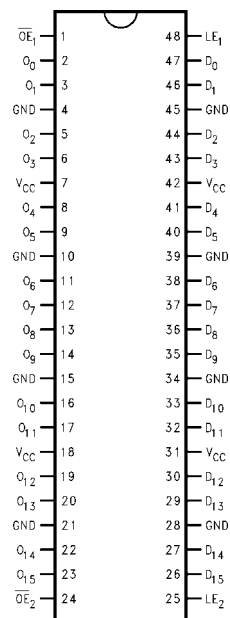

Pin Descriptions

Pin Names	Description
\overline{OE}_n	Output Enable Input (Active LOW)
LE_n	Latch Enable Input
D_0 - D_{15}	Data Inputs
O_0 - O_{15}	Outputs

Functional Description

The ABT16373 contains sixteen D-type latches with 3-STATE standard outputs. The device is byte controlled with each byte functioning identically, but independent of the other. Control pins can be shorted together to obtain full 16-bit operation. The following description applies to each byte. When the Latch Enable (LE_n) input is HIGH, data on the D_n enters the latches. In this condition the latches are transparent, i.e., a latch output will change states each time its D input changes. When LE_n is LOW, the latches store information that was present on the D inputs a setup time preceding the HIGH-to-LOW transition of LE_n . The 3-STATE standard outputs are controlled by the Output Enable (\overline{OE}_n) input. When \overline{OE}_n is LOW, the standard outputs are in the 2-state mode. When \overline{OE}_n is HIGH, the standard outputs are in the high impedance mode but this does not interfere with entering new data into the latches.

Truth Tables

Inputs			Outputs
LE_1	\overline{OE}_1	D_0-D_7	O_0-O_7
X	H	X	Z
H	L	L	L
H	L	H	H
L	L	X	(Previous)

Inputs			Outputs
LE_2	\overline{OE}_2	D_8-D_{15}	O_8-O_{15}
X	H	X	Z
H	L	L	L
H	L	H	H
L	L	X	(Previous)

H = HIGH Voltage Level

L = LOW Voltage Level

X = Immaterial

Z = High Impedance

Previous = previous output prior to HIGH-to-LOW transition of LE

Logic Diagrams

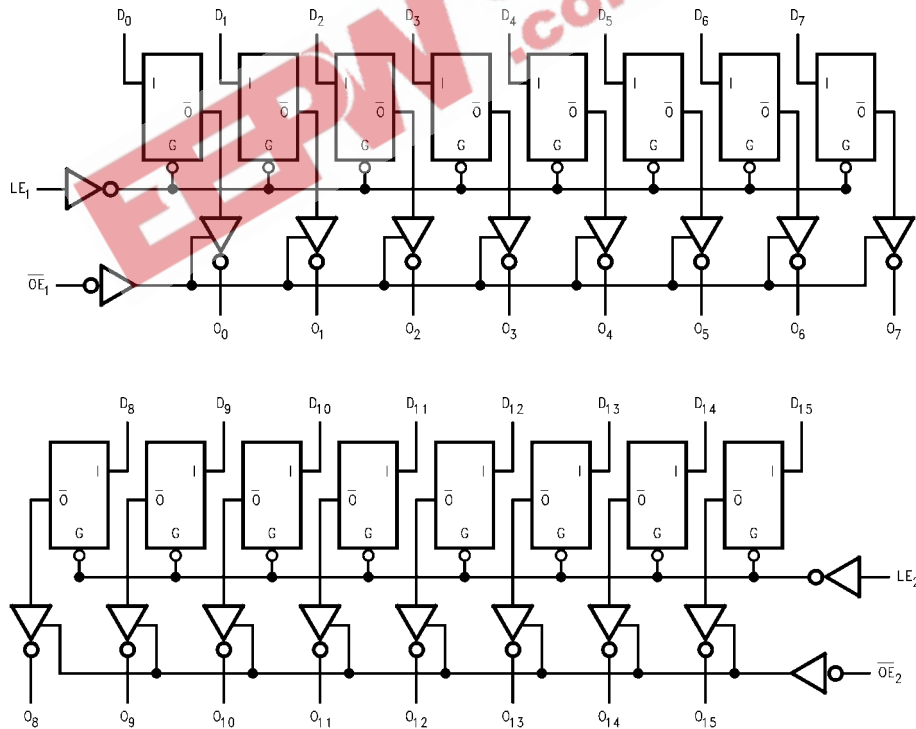

Absolute Maximum Ratings (Note 1)		Recommended Operating Conditions	
Storage Temperature	-65°C to +150°C	Free Air Ambient Temperature	-40°C to +85°C
Ambient Temperature under Bias	-55°C to +125°C	Supply Voltage	+4.5V to +5.5V
Junction Temperature under Bias	-55°C to +150°C	Minimum Input Edge Rate ($\Delta V/\Delta t$)	
V_{CC} Pin Potential to Ground Pin	-0.5V to +7.0V	Data Input	50 mV/ns
Input Voltage (Note 2)	-0.5V to +7.0V	Enable Input	20 mV/ns
Input Current (Note 2)	-30 mA to +5.0 mA		
Voltage Applied to Any Output in the Disabled or Power-Off State	-0.5V to +5.5V		
in the HIGH State	-0.5V to V_{CC}		
Current Applied to Output in LOW State (Max)	twice the rated I_{OL} (mA)		
DC Latchup Source Current: \overline{OE} Pin (Across Comm Operating Range)	-350 mA		
Other Pins	-500 mA		
Over Voltage Latchup (I/O)	10V		

Note 1: Absolute maximum ratings are values beyond which the device may be damaged or have its useful life impaired. Functional operation under these conditions is not implied.

Note 2: Either voltage limit or current limit is sufficient to protect inputs.

DC Electrical Characteristics

Symbol	Parameter	Min	Typ	Max	Units	V_{CC}	Conditions
V_{IH}	Input HIGH Voltage	2.0			V		Recognized HIGH Signal
V_{IL}	Input LOW Voltage			0.8	V		Recognized LOW Signal
V_{CD}	Input Clamp Diode Voltage			-1.2	V	Min	$I_{IN} = -18$ mA
V_{OH}	Output HIGH Voltage	2.5 2.0				Min	$I_{OH} = -3$ mA $I_{OH} = -32$ mA
V_{OL}	Output LOW Voltage			0.55	V	Min	$I_{OL} = 64$ mA
I_{IH}	Input HIGH Current			1 1	μ A	Max	$V_{IN} = 2.7V$ (Note 3) $V_{IN} = V_{CC}$
I_{BVI}	Input HIGH Current Breakdown Test			7	μ A	Max	$V_{IN} = 7.0V$
I_{IL}	Input LOW Current			-1 -1	μ A	Max	$V_{IN} = 0.5V$ (Note 3) $V_{IN} = 0.0V$
V_{ID}	Input Leakage Test	4.75			V	0.0	$I_{ID} = 1.9$ μ A All Other Pins Grounded
I_{OZH}	Output Leakage Current			10	μ A	0 - 5.5V	$V_{OUT} = 2.7V$; $\overline{OE} = 2.0V$
I_{OZL}	Output Leakage Current			-10	μ A	0 - 5.5V	$V_{OUT} = 0.5V$; $\overline{OE} = 2.0V$
I_{OS}	Output Short-Circuit Current	-100		-275	mA	Max	$V_{OUT} = 0.0V$
I_{CEX}	Output HIGH Leakage Current			50	μ A	Max	$V_{OUT} = V_{CC}$
I_{ZZ}	Bus Drainage Test			100	μ A	0.0	$V_{OUT} = 5.5V$; All Others GND
I_{CCH}	Power Supply Current			2.0	mA	Max	All Outputs HIGH
I_{CCL}	Power Supply Current			62	mA	Max	All Outputs LOW
I_{CCZ}	Power Supply Current			2.0	mA	Max	$\overline{OE} = V_{CC}$ All Others at V_{CC} or GND
I_{CCT}	Additional I_{CC} /Input			2.5 2.5 2.5	mA	Max	$V_1 = V_{CC} - 2.1V$ Enable Input $V_1 = V_{CC} - 2.1V$ Data Input $V_1 = V_{CC} - 2.1V$ All Others at V_{CC} or GND
I_{CCD}	Dynamic I_{CC} (Note 3)			0.15	mA/ MHz	Max	Outputs Open, $LE = V_{CC}$ $\overline{OE} = GND$, (Note 4) One Bit Toggling, 50% Duty Cycle

Note 3: Guaranteed, but not tested.

Note 4: For 8 bits toggling, $I_{CCD} < 0.8$ mA/MHz.

74ABT16373

AC Electrical Characteristics							
(SOIC and SSOP Packages)							
Symbol	Parameter	T _A = +25°C V _{CC} = +5.0V C _L = 50 pF			T _A = -40°C to +85°C V _{CC} = 4.5V to 5.5V C _L = 50 pF		Units
		Min	Typ	Max	Min	Max	
t _{PLH}	Propagation Delay	1.4		5.6	1.4	5.6	ns
t _{PHL}	D _n to O _n	1.4		5.6	1.4	5.6	
t _{PLH}	Propagation Delay	1.7		6.0	1.7	6.0	ns
t _{PHL}	LE to O _n	1.7		5.5	1.7	5.5	
t _{PZH}	Output Enable Time	1.1		6.1	1.1	6.1	ns
t _{PZL}		1.5		5.6	1.5	5.6	
t _{PHZ}	Output Disable Time	2.4		7.1	2.4	7.1	ns
t _{PLZ}		1.6		6.5	1.6	6.5	

AC Operating Requirements							
(SOIC and SSOP Packages)							
Symbol	Parameter	T _A = +25°C V _{CC} = +5.0V C _L = 50 pF			T _A = -40°C to +85°C V _{CC} = 4.5V to 5.5V C _L = 50 pF		Units
		Min	Typ	Max	Min	Max	
t _{TOGGLE}	Maximum Toggle Frequency		100				MHz
t _{S(H)}	Setup Time, HIGH	1.5			1.5		ns
t _{S(L)}	or LOW D _n to LE	1.5			1.5		
t _{H(H)}	Hold Time, HIGH	1.0			1.0		ns
t _{H(L)}	or LOW D _n to LE	1.0			1.0		
t _{W(H)}	Pulse Width, LE HIGH	3.0			3.0		ns

Capacitance				
Symbol	Parameter	Typ	Units	Conditions (T _A = 25°C)
C _{IN}	Input Capacitance	5	pF	V _{CC} = 0V
C _{OUT} (Note 5)	Output Capacitance	11	pF	V _{CC} = 5.0V

Note 5: C_{OUT} is measured at frequency f = 1 MHz, per MIL-STD-883, Method 3012.

Physical Dimensions inches (millimeters) unless otherwise noted

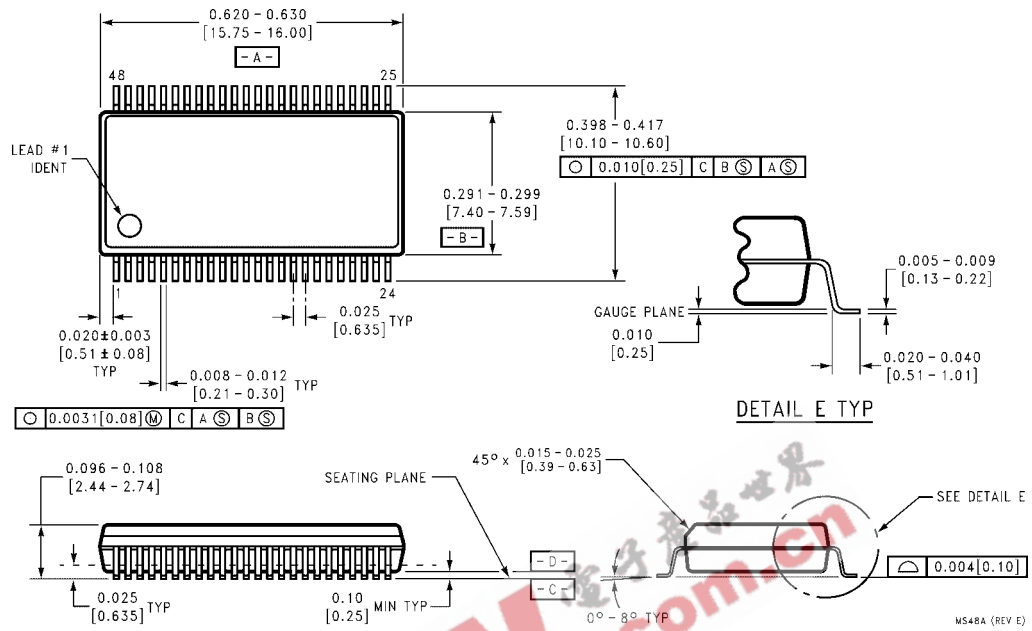

**48-Lead Small Shrink Outline Package (SSOP), JEDEC MO-118, 0.300" Wide
Package Number MS48A**

Physical Dimensions inches (millimeters) unless otherwise noted (Continued)

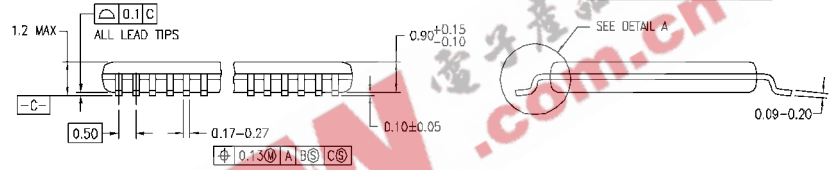
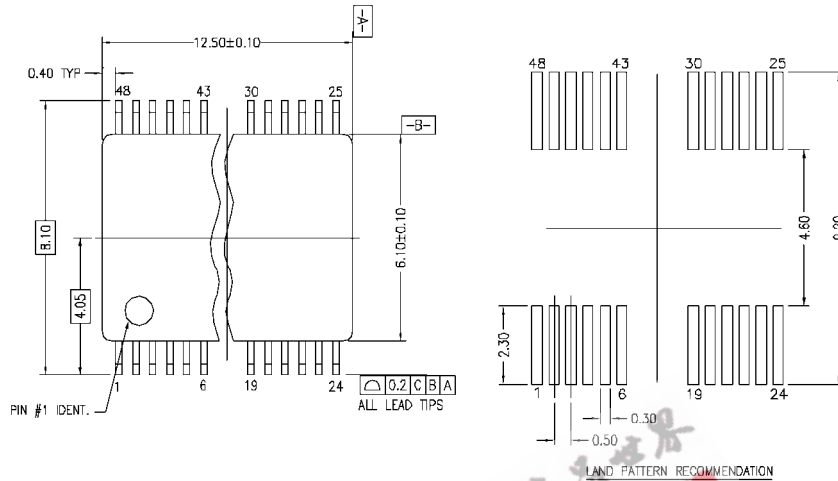

DIMENSIONS ARE IN MILLIMETERS

NOTES:

- A. CONFORMS TO JEDEC REGISTRATION MO-153, VARIATION ED, DATE 4/97.
- B. DIMENSIONS ARE IN MILLIMETERS.
- C. DIMENSIONS ARE EXCLUSIVE OF BURRS, MOLD FLASH, AND TIE BAR EXTRUSIONS.
- D. DIMENSIONS AND TOLERANCES PER ANSI Y14.5M, 1982.

MTD48REV C

48-Lead Thin Shrink Small Outline Package (TSSOP), JEDEC MO-153, 6.1mm Wide Package Number MTD48

Fairchild does not assume any responsibility for use of any circuitry described, no circuit patent licenses are implied and Fairchild reserves the right at any time without notice to change said circuitry and specifications.

LIFE SUPPORT POLICY

FAIRCHILD'S PRODUCTS ARE NOT AUTHORIZED FOR USE AS CRITICAL COMPONENTS IN LIFE SUPPORT DEVICES OR SYSTEMS WITHOUT THE EXPRESS WRITTEN APPROVAL OF THE PRESIDENT OF FAIRCHILD SEMICONDUCTOR CORPORATION. As used herein:

1. Life support devices or systems are devices or systems which, (a) are intended for surgical implant into the body, or (b) support or sustain life, and (c) whose failure to perform when properly used in accordance with instructions for use provided in the labeling, can be reasonably expected to result in a significant injury to the user.
2. A critical component in any component of a life support device or system whose failure to perform can be reasonably expected to cause the failure of the life support device or system, or to affect its safety or effectiveness.

www.fairchildsemi.com