

DM74LS253

3-STATE Data Selector/Multiplexer

General Description

Each of these Schottky-clamped data selectors/multiplexers contains inverters and drivers to supply fully complementary, on-chip, binary decoding data selection to the AND-OR gates. Separate output control inputs are provided for each of the two four-line sections.

The 3-STATE outputs can interface directly with data lines of bus-organized systems. With all but one of the common outputs disabled (at a high impedance state), the low impedance of the single enabled output will drive the bus line to a HIGH or LOW logic level.

Features

- 3-STATE version of DM74LS153 with same pinout
- Schottky-diode-clamped transistors
- Permit multiplexing from N-lines to one line
- Performs parallel-to-serial conversion
- Strobe/output control
- High fanout totem-pole outputs
- Typical propagation delay
 - Data to output 12 ns
 - Select to output 21 ns
- Typical power dissipation 35 mW

Ordering Code:

Order Number	Package Number	Package Description
DM74LS253M	M16A	16-Lead Small Outline Integrated Circuit (SOIC), JEDEC MS-012, 0.150 Narrow
DM74LS253N	N16E	16-Lead Plastic Dual-In-Line Package (PDIP), JEDEC MS-001, 0.300 Wide

Devices also available in Tape and Reel. Specify by appending the suffix letter "X" to the ordering code.

Connection Diagram

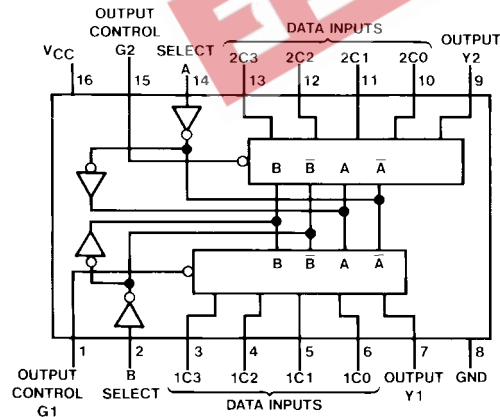

Function Table

Select Inputs		Data Inputs				Output Control	Output
B	A	C0	C1	C2	C3	G	Y
X	X	X	X	X	X	H	Z
L	L	L	X	X	X	L	L
L	L	H	X	X	X	L	H
L	H	X	L	X	X	L	L
L	H	X	H	X	X	L	H
H	L	X	X	L	X	L	L
H	L	X	X	H	X	L	H
H	H	X	X	X	L	L	L
H	H	X	X	X	H	L	H

Address Inputs A and B are common to both sections.

H = HIGH Level
L = LOW Level
X = Don't Care
Z = High Impedance (OFF)

Logic Diagram

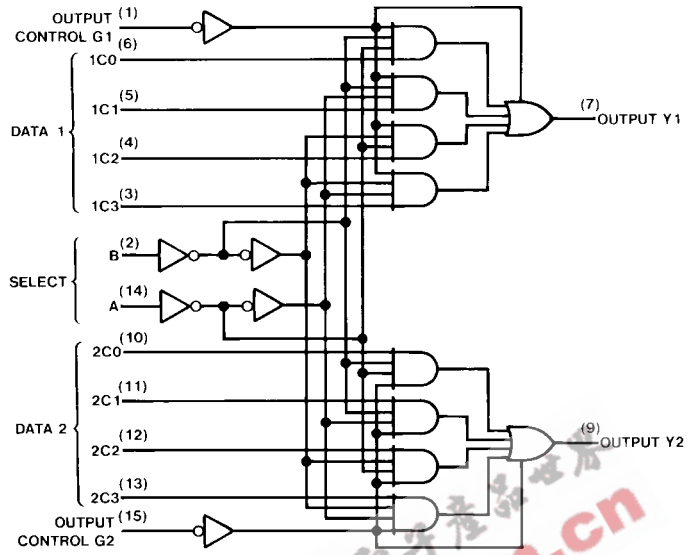

EEPW.com.cn

Absolute Maximum Ratings(Note 1)

Supply Voltage	7V
Input Voltage	7V
Operating Free Air Temperature Range	0°C to +70°C
Storage Temperature Range	-65°C to +150°C

Note 1: The "Absolute Maximum Ratings" are those values beyond which the safety of the device cannot be guaranteed. The device should not be operated at these limits. The parametric values defined in the "Electrical Characteristics" table are not guaranteed at the absolute maximum ratings. The "Recommended Operating Conditions" table will define the conditions for actual device operation.

Recommended Operating Conditions

Symbol	Parameter	Min	Nom	Max	Units
V _{CC}	Supply Voltage	4.75	5	5.25	V
V _{IH}	HIGH Level Input Voltage	2			V
V _{IL}	LOW Level Input Voltage			0.8	V
I _{OH}	HIGH Level Output Current			-2.6	mA
I _{OL}	LOW Level Output Current			24	mA
T _A	Free Air Operating Temperature	0		70	°C

Electrical Characteristics

over recommended operating free air temperature range (unless otherwise noted)

Symbol	Parameter	Conditions	Min	Typ (Note 2)	Max	Units
V _I	Input Clamp Voltage	V _{CC} = Min, I _I = -18 mA			-1.5	V
V _{OH}	HIGH Level Output Voltage	V _{CC} = Min, I _{OH} = Max V _{IL} = Max, V _{IH} = Min	2.4	3.1		V
V _{OL}	LOW Level Output Voltage	V _{CC} = Min, I _{OL} = Max V _{IL} = Max, V _{IH} = Min			0.5	V
		I _{OL} = 12 mA, V _{CC} = Min			0.4	
I _I	Input Current @ Max Input Voltage	V _{CC} = Max, V _I = 7V			0.1	mA
I _{IH}	HIGH Level Input Current	V _{CC} = Max, V _I = 2.7V			20	μA
I _{IL}	LOW Level Input Current	V _{CC} = Max, V _I = 0.4V			-0.4	mA
I _{OZH}	Off-State Output Current with HIGH Level Output Voltage Applied	V _{CC} = Max, V _O = 2.7V V _{IH} = Min, V _{IL} = Max			20	μA
		V _{CC} = Max, V _O = 0.4V V _{IH} = Min, V _{IL} = Max			-20	
I _{OS}	Short Circuit Output Current	V _{CC} = Max (Note 3)	-20		-100	mA
I _{CC1}	Supply Current	V _{CC} = Max (Note 4)		7	12	mA
I _{CC2}	Supply Current	V _{CC} = Max (Note 5)		8.5	14	mA

Note 2: All typicals are at V_{CC} = 5V, T_A = 25°C.

Note 3: Not more than one output should be shorted at a time, and the duration should not exceed one second.

Note 4: I_{CC1} is measured with all outputs OPEN, and all the inputs grounded.

Note 5: I_{CC2} is measured with the outputs OPEN, OUTPUT CONTROL at 4.5V and all other inputs grounded.

Switching Characteristics

at $V_{CC} = 5V$ and $T_A = 25^\circ C$

Symbol	Parameter	From (Input) To (Output)	$R_L = 667\Omega$				Units
			$C_L = 45\text{ pF}$		$C_L = 150\text{ pF}$		
			Min	Max	Min	Max	
t_{PLH}	Propagation Delay Time LOW-to-HIGH Level Output	Data to Y		25		35	ns
t_{PHL}	Propagation Delay Time HIGH-to-LOW Level Output	Data to Y		20		30	ns
t_{PLH}	Propagation Delay Time LOW-to-HIGH Level Output	Select to Y		45		54	ns
t_{PHL}	Propagation Delay Time HIGH-to-LOW Level Output	Select to Y		32		44	ns
t_{PZH}	Output Enable Time to HIGH Level Output	Output Control to Y		18		32	ns
t_{PZL}	Output Enable Time to LOW Level Output	Output Control to Y		23		35	ns
t_{PHZ}	Output Disable Time from HIGH Level Output (Note 6)	Output Control to Y		41			ns
t_{PLZ}	Output Disable Time from LOW Level Output (Note 6)	Output Control to Y		27			ns

Note 6: $C_L = 5\text{ pF}$.

Physical Dimensions inches (millimeters) unless otherwise noted

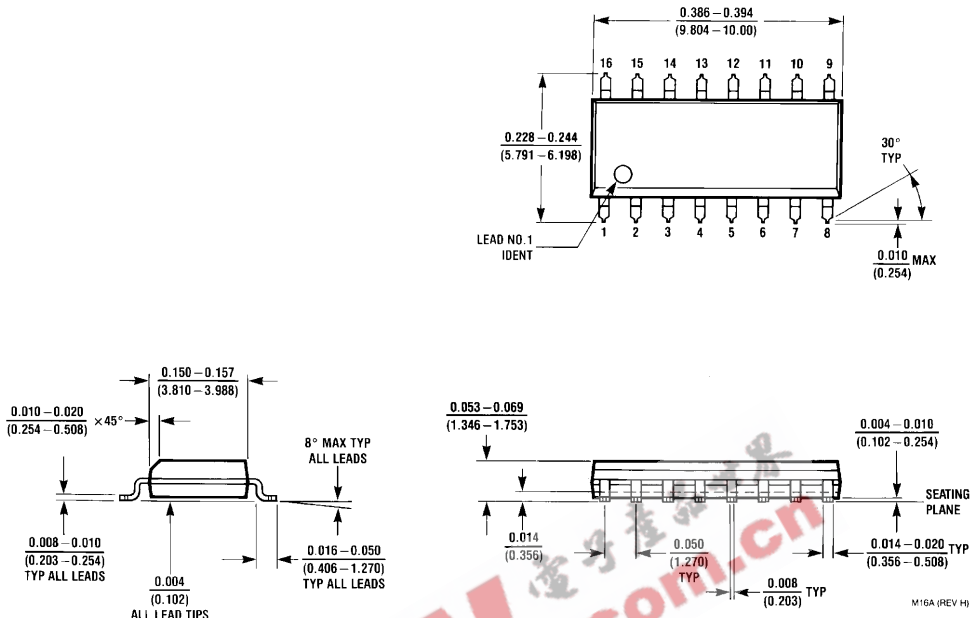

**16-Lead Small Outline Integrated Circuit (SOIC), JEDEC MS-012, 0.150 Narrow
Package Number M16A**

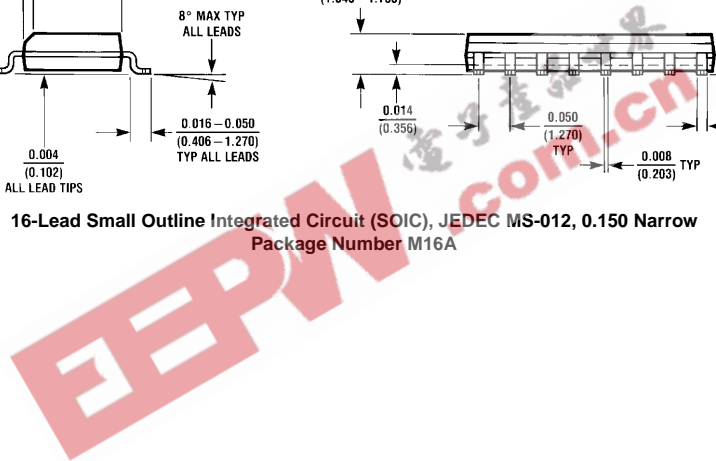

Physical Dimensions inches (millimeters) unless otherwise noted (Continued)

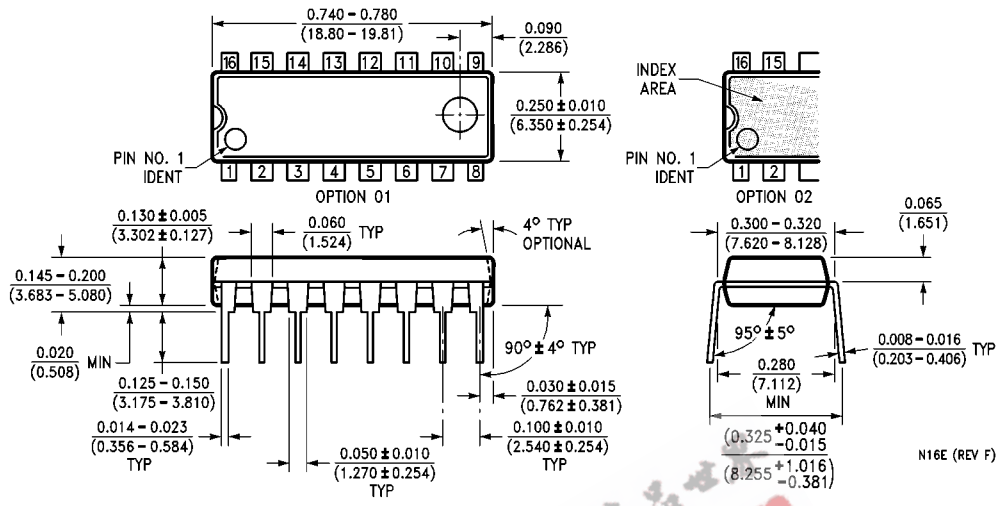

**16-Lead Plastic Dual-In-Line Package (PDIP), JEDEC MS-001, 0.300 Wide
Package Number N16E**

N16E (REV F)

Fairchild does not assume any responsibility for use of any circuitry described, no circuit patent licenses are implied and Fairchild reserves the right at any time without notice to change said circuitry and specifications.

LIFE SUPPORT POLICY

FAIRCHILD'S PRODUCTS ARE NOT AUTHORIZED FOR USE AS CRITICAL COMPONENTS IN LIFE SUPPORT DEVICES OR SYSTEMS WITHOUT THE EXPRESS WRITTEN APPROVAL OF THE PRESIDENT OF FAIRCHILD SEMICONDUCTOR CORPORATION. As used herein:

1. Life support devices or systems are devices or systems which, (a) are intended for surgical implant into the body, or (b) support or sustain life, and (c) whose failure to perform when properly used in accordance with instructions for use provided in the labeling, can be reasonably expected to result in a significant injury to the user.
2. A critical component in any component of a life support device or system whose failure to perform can be reasonably expected to cause the failure of the life support device or system, or to affect its safety or effectiveness.

www.fairchildsemi.com