

MONOLITHIC 5-TAP 3.3V FIXED DELAY LINE (SERIES 3D3215)



FEATURES

- All-silicon, low-power 3.3V CMOS technology
- Vapor phase, IR and wave solderable
- Auto-insertable (DIP pkg.)
- Low ground bounce noise
- Leading- and trailing-edge accuracy
- **Delay range:** 1.5ns through 300ns
- **Total delay tolerance:** 2% or 0.5ns (3.3V, 25C)
- **Temperature stability:** $\pm 1\%$ typical (0C-70C)
- **Vdd stability:** $\pm 1\%$ typical (3.0V-3.6V)
- **Static Idd:** 1.3ma typical
- **Minimum input pulse width:** 25% of total delay

PACKAGES

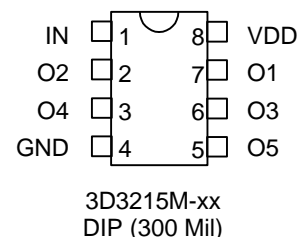
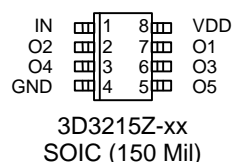

For mechanical dimensions, click [here](#).
For package marking details, click [here](#).

FUNCTIONAL DESCRIPTION

The 3D3215 5-Tap Delay Line product family consists of fixed-delay 3.3V CMOS integrated circuits. Each package contains a single delay line, tapped and buffered at 5 points spaced uniformly in time. Tap-to-tap (incremental) delay values can range from 1.5ns through 60ns. The input is reproduced at the outputs without inversion, shifted in time as per the user-specified dash number. The 3D3215 is 3.3V CMOS-compatible and features both rising- and falling-edge accuracy.

The all-CMOS 3D3215 integrated circuit has been designed as a reliable, economic alternative to hybrid fixed delay lines. It is offered in a standard 8-pin auto-insertable DIP and a space saving surface mount 8-pin SOIC.

PIN DESCRIPTIONS

IN	Delay Line Input
O1	Tap 1 Output (20%)
O2	Tap 2 Output (40%)
O3	Tap 3 Output (60%)
O4	Tap 4 Output (80%)
O5	Tap 5 Output (100%)
VDD	+3.3 Volts
GND	Ground
N/C	No Connection

TABLE 1: PART NUMBER SPECIFICATIONS

DASH # 3D3215Z-xx 3D3215M-xx	DELAY SPECIFICATIONS		INPUT RESTRICTIONS			
	TOTAL DELAY (ns)	TAP-TAP DELAY (ns)	RECOMMENDED		ABSOLUTE	
			Max Freq	Min P.W.	Max Freq	Min P.W.
-1.5	6.0 \pm 0.5*	1.5 \pm 0.7	23.8 MHz	21.0 ns	83.3 MHz	6.00 ns
-2	8.0 \pm 0.5*	2.0 \pm 0.8	20.8 MHz	24.0 ns	83.3 MHz	6.00 ns
-2.5	10.0 \pm 0.5*	2.5 \pm 1.0	18.5 MHz	27.0 ns	66.7 MHz	7.50 ns
-3	12.0 \pm 0.5*	3.0 \pm 1.3	16.7 MHz	30.0 ns	55.6 MHz	9.00 ns
-4	16.0 \pm 0.5*	4.0 \pm 1.3	13.9 MHz	36.0 ns	50.0 MHz	10.00 ns
-5	20.0 \pm 0.5*	5.0 \pm 1.4	11.9 MHz	42.0 ns	40.0 MHz	12.50 ns
-6	24.0 \pm 0.5*	6.0 \pm 1.4	10.4 MHz	48.0 ns	55.6 MHz	9.00 ns
-8	40.0 \pm 0.8	8.0 \pm 1.4	8.33 MHz	60.0 ns	41.7 MHz	12.00 ns
-10	50.0 \pm 1.0	10.0 \pm 1.5	6.67 MHz	75.0 ns	40.0 MHz	12.50 ns
-12	60.0 \pm 1.2	12.0 \pm 1.5	5.56 MHz	90.0 ns	33.3 MHz	15.00 ns
-15	75.0 \pm 1.5	15.0 \pm 1.5	4.42 MHz	113 ns	26.7 MHz	18.75 ns
-20	100 \pm 2.0	20.0 \pm 2.0	3.33 MHz	150 ns	20.0 MHz	25.00 ns
-25	125 \pm 2.5	25.0 \pm 2.5	2.66 MHz	188 ns	16.0 MHz	31.25 ns
-30	150 \pm 3.0	30.0 \pm 3.0	2.22 MHz	225 ns	13.3 MHz	37.50 ns
-40	200 \pm 4.0	40.0 \pm 4.0	1.67 MHz	300 ns	10.0 MHz	50.00 ns
-50	250 \pm 5.0	50.0 \pm 5.0	1.33 MHz	375 ns	8.0 MHz	62.50 ns
-60	300 \pm 6.0	60.0 \pm 6.0	1.11 MHz	450 ns	6.7 MHz	75.00 ns

* Total delay referenced to Tap1 output; Input-to-Tap1 = 7.5ns \pm 1.5ns

NOTE: Any dash number between 1.5 and 60 not shown is also available as standard

©2001 Data Delay Devices

APPLICATION NOTES

OPERATIONAL DESCRIPTION

The 3D3215 five-tap delay line architecture is shown in Figure 1. The delay line is composed of a number of delay cells connected in series. Each delay cell produces at its output a replica of the signal present at its input, shifted in time. The delay cells are matched and share the same compensation signals, which minimizes tap-to-tap delay deviations over temperature and supply voltage variations.

INPUT SIGNAL CHARACTERISTICS

The Frequency and/or Pulse Width (high or low) of operation may adversely impact the specified delay accuracy of the particular device. The reasons for the dependency of the output delay accuracy on the input signal characteristics are varied and complex. Therefore a **Recommended Maximum** and an **Absolute Maximum** operating input frequency and a **Recommended Minimum** and an **Absolute Minimum** operating pulse width have been specified.

OPERATING FREQUENCY

The **Absolute Maximum Frequency** specification, tabulated in Table 1, determines the highest frequency of the delay line input signal that can be reproduced, shifted in time at the device output, with acceptable duty cycle distortion.

The **Recommended Maximum Frequency** specification determines the highest frequency of the delay line input signal for which the output

delay accuracy is guaranteed. To guarantee the Table 1 delay accuracy for input frequencies higher than the Recommended Maximum Frequency, the 3D3215 must be tested at the user operating frequency. Therefore, to facilitate production and device identification, the part number will include a custom reference designator identifying the intended frequency of operation. The programmed delay accuracy of the device is guaranteed, therefore, only at the user specified input frequency. Small input frequency variation about the selected frequency will only marginally impact the programmed delay accuracy, if at all. **Nevertheless, it is strongly recommended that the engineering staff at DATA DELAY DEVICES be consulted.**

OPERATING PULSE WIDTH

The **Absolute Minimum Pulse Width** (high or low) specification, tabulated in Table 1, determines the smallest Pulse Width of the delay line input signal that can be reproduced, shifted in time at the device output, with acceptable pulse width distortion.

The **Recommended Minimum Pulse Width** (high or low) specification determines the smallest Pulse Width of the delay line input signal for which the output delay accuracy tabulated in Table 1 is guaranteed.

To guarantee the Table 1 delay accuracy for input pulse width smaller than the Recommended Minimum Pulse Width, the 3D3215 must be tested at the user operating pulse width. Therefore, to facilitate production and device

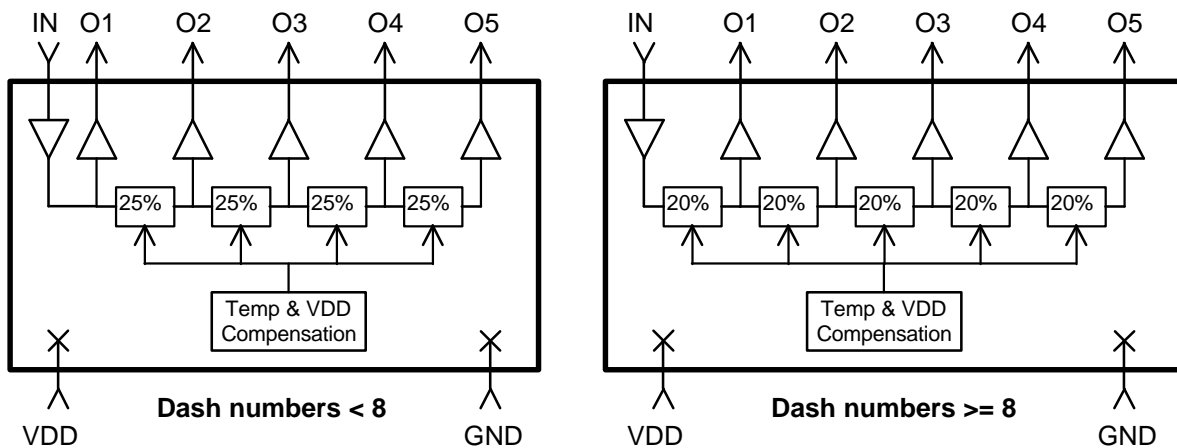

Figure 1: 3D3215 Functional Diagram

APPLICATION NOTES (CONT'D)

identification, the part number will include a custom reference designator identifying the intended frequency and duty cycle of operation. The programmed delay accuracy of the device is guaranteed, therefore, only for the user specified input characteristics. Small input pulse width variation about the selected pulse width will only marginally impact the programmed delay accuracy, if at all. **Nevertheless, it is strongly recommended that the engineering staff at DATA DELAY DEVICES be consulted.**

POWER SUPPLY AND TEMPERATURE CONSIDERATIONS

The delay of CMOS integrated circuits is strongly dependent on power supply and temperature. The monolithic 3D3215 delay line utilizes novel and innovative compensation circuitry to minimize the delay variations induced by fluctuations in power supply and/or temperature.

The thermal coefficient is reduced to 200 PPM/C, which is equivalent to a variation, over the 0C-70C operating range, of $\pm 1\%$ or 0.25ns (whichever is greater) from the 25C delay settings. The power supply coefficient is reduced, over the 3.0V-3.6V operating range, to $\pm 1\%$ or 1ns (whichever is greater) of the delay settings at the nominal 3.3VDC power supply.

The temperature and power supply sensitivities are based on the measured delay of Tap 5 with respect to Tap 1. The sensitivity of the Input-to-Tap 1 delay will be somewhat higher, particularly with the smaller dash numbers.

It is essential that the power supply pin be adequately bypassed and filtered. In addition, the power bus should be of as low an impedance construction as possible. Power planes are preferred.

DEVICE SPECIFICATIONS

TABLE 2: ABSOLUTE MAXIMUM RATINGS

PARAMETER	SYMBOL	MIN	MAX	UNITS	NOTES
DC Supply Voltage	V_{DD}	-0.3	7.0	V	
Input Pin Voltage	V_{IN}	-0.3	$V_{DD}+0.3$	V	
Input Pin Current	I_{IN}	-1.0	1.0	mA	25C
Storage Temperature	T_{STRG}	-55	150	C	
Lead Temperature	T_{LEAD}		300	C	10 sec

TABLE 3: DC ELECTRICAL CHARACTERISTICS

(0C to 70C, 3.0V to 3.6V)

PARAMETER	SYMBOL	MIN	TYP	MAX	UNITS	NOTES
Static Supply Current*	I_{DD}		1.3	2.0	mA	$V_{DD} = 3.6V$
High Level Input Voltage	V_{IH}	2.0			V	
Low Level Input Voltage	V_{IL}			0.8	V	
High Level Input Current	I_{IH}	-0.1	0.0	0.1	μA	$V_{IH} = V_{DD}$
Low Level Input Current	I_{IL}	-0.1	0.0	0.1	μA	$V_{IL} = 0V$
High Level Output Current	I_{OH}		-8.0	-6.0	mA	$V_{DD} = 3.0V$ $V_{OH} = 2.4V$
Low Level Output Current	I_{OL}	6.0	7.5		mA	$V_{DD} = 3.0V$ $V_{OL} = 0.4V$
Output Rise & Fall Time	T_R & T_F		2		ns	$C_{LD} = 5$ pf

* $I_{DD}(\text{Dynamic}) = 5 * C_{LD} * V_{DD} * F$
 where: C_{LD} = Average capacitance load/tap (pf)
 F = Input frequency (GHz)

Input Capacitance = 10 pf typical
 Output Load Capacitance (C_{LD}) = 25 pf max

SILICON DELAY LINE AUTOMATED TESTING

TEST CONDITIONS

INPUT:

Ambient Temperature: $25^{\circ}\text{C} \pm 3^{\circ}\text{C}$
Supply Voltage (Vcc): $3.3\text{V} \pm 0.1\text{V}$
Input Pulse: High = $3.3\text{V} \pm 0.1\text{V}$
 Low = $0.0\text{V} \pm 0.1\text{V}$
Source Impedance: 50Ω Max.
Rise/Fall Time: 3.0 ns Max. (measured between 0.6V and 2.4V)
Pulse Width: $\text{PW}_{\text{IN}} = 1.5 \times \text{Total Delay}$
Period: $\text{PER}_{\text{IN}} = 3.0 \times \text{Total Delay}$

OUTPUT:

R_{load}: $10\text{K}\Omega \pm 10\%$
C_{load}: $5\text{pf} \pm 10\%$
Threshold: 1.5V (Rising & Falling)

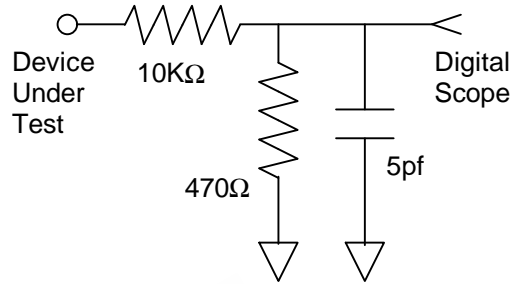

NOTE: The above conditions are for test only and do not in any way restrict the operation of the device.

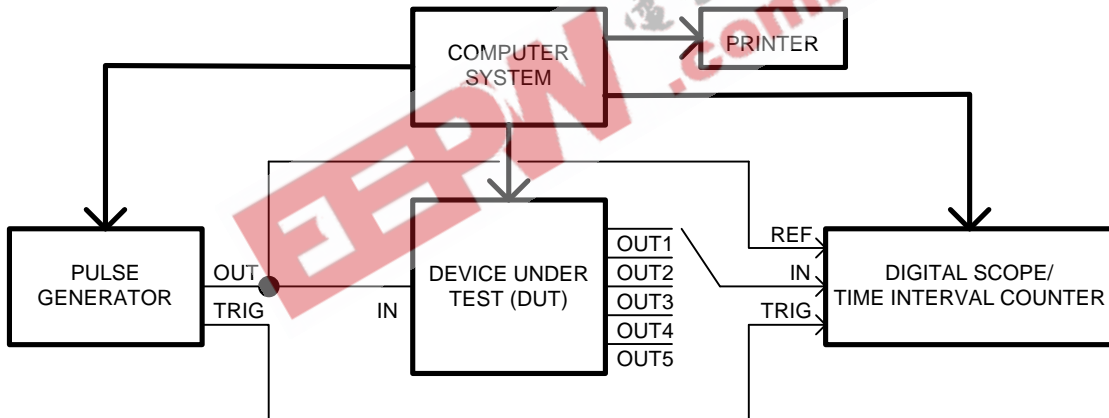

Figure 2: Test Setup

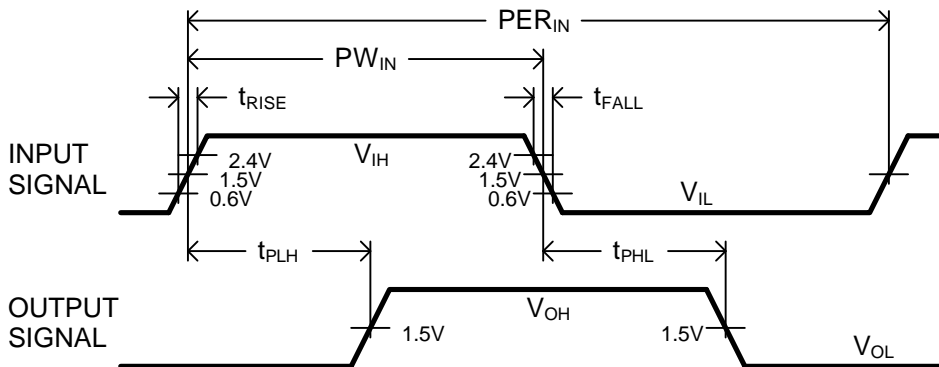

Figure 3: Timing Diagram