

74AC16244 • 74ACT16244

16-Bit Buffer/Line Driver with 3-STATE Outputs

General Description

The AC16244 and ACT16244 contain sixteen non-inverting buffers with 3-STATE outputs designed to be employed as a memory and address driver, clock driver, or bus oriented transmitter/receiver. The device is nibble controlled. Each nibble has separate 3-STATE control inputs which can be shorted together for full 16-bit operation.

Features

- Separate control logic for each byte and nibble
- 16-bit version of the AC244/ACT244
- Outputs source/sink 24 mA
- ACT16244 has TTL-compatible inputs

Ordering Code:

| Order Number | Package Number | Package Description |
|---------------|----------------|---|
| 74AC16244SSC | MS48A | 48-Lead Small Shrink Outline Package (SSOP), JEDEC MO-118, 0.300" Wide |
| 74ACT16244SSC | MS48A | 48-Lead Small Shrink Outline Package (SSOP), JEDEC MO-118, 0.300" Wide |
| 74ACT16244MTD | MTD48 | 48-Lead Thin Shrink Small Outline Package (TSSOP), JEDEC MO-153, 6.1mm Wide |

Device also available in Tape and Reel. Specify by appending suffix letter "X" to the ordering code.

Logic Symbol

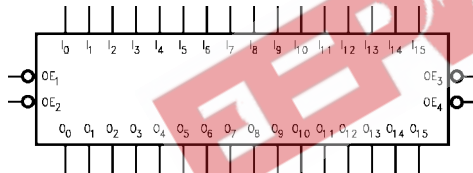

Connection Diagram

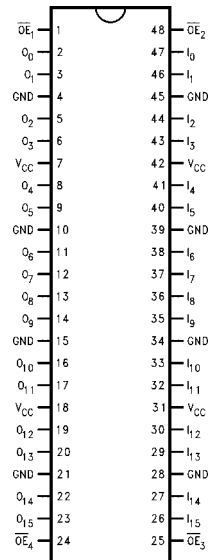

Pin Descriptions

| Pin Names | Description |
|-------------------|----------------------------------|
| \overline{OE}_n | Output Enable Input (Active LOW) |
| $I_0 - I_{15}$ | Inputs |
| $O_0 - O_{15}$ | Outputs |

FACT™ is a trademark of Fairchild Semiconductor Corporation.

Functional Description

The AC16244 and ACT16244 contain sixteen non-inverting buffers with 3-STATE standard outputs. The device is nibble (4 bits) controlled with each nibble functioning identically, but independent of the other. The control pins can be shorted together to obtain full 16-bit operation. The

3-STATE outputs are controlled by an Output Enable (\overline{OE}_n) input for each nibble. When \overline{OE}_n is LOW, the outputs are in 2-state mode. When \overline{OE}_n is HIGH, the outputs are in the high impedance mode, but this does not interfere with entering new data into the inputs.

Truth Tables

| Inputs | | Outputs |
|-------------------|--------------------------------|--------------------------------|
| \overline{OE}_1 | I ₀ -I ₃ | O ₀ -O ₃ |
| L | L | L |
| L | H | H |
| H | X | Z |

| Inputs | | Outputs |
|-------------------|--------------------------------|--------------------------------|
| \overline{OE}_2 | I ₄ -I ₇ | O ₄ -O ₇ |
| L | L | L |
| L | H | H |
| H | X | Z |

| Inputs | | Outputs |
|-------------------|---------------------------------|---------------------------------|
| \overline{OE}_3 | I ₈ -I ₁₁ | O ₈ -O ₁₁ |
| L | L | L |
| L | H | H |
| H | X | Z |

| Inputs | | Outputs |
|-------------------|----------------------------------|----------------------------------|
| \overline{OE}_4 | I ₁₂ -I ₁₅ | O ₁₂ -O ₁₅ |
| L | L | L |
| L | H | H |
| H | X | Z |

L = LOW Voltage Level
H = HIGH Voltage Level

X = Immaterial
Z = High Impedance

Logic Diagram

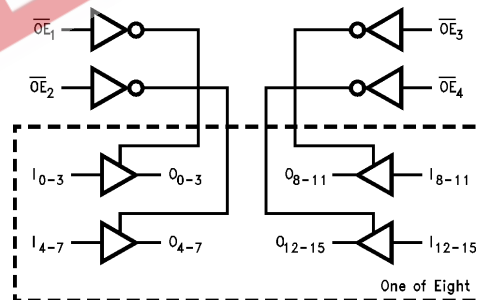

Absolute Maximum Ratings (Note 1)

| | |
|---|--------------------------|
| Supply Voltage (V_{CC}) | -0.5V to +7.0V |
| DC Input Diode Current (I_{IK}) | |
| $V_I = -0.5V$ | -20 mA |
| $V_I = V_{CC} + 0.5V$ | +20 mA |
| DC Output Diode Current (I_{OK}) | |
| $V_O = -0.5V$ | -20 mA |
| $V_O = V_{CC} + 0.5V$ | +20 mA |
| DC Output Voltage (V_O) | -0.5V to $V_{CC} + 0.5V$ |
| DC Output Source/Sink Current (I_O) | ± 50 mA |
| DC V_{CC} or Ground Current | |
| per Output Pin | ± 50 mA |
| Junction Temperature | +140°C |
| Storage Temperature | -65°C to +150°C |

Recommended Operating Conditions

| | |
|---|----------------|
| Supply Voltage (V_{CC}) | |
| AC | 2.0V to 6.0V |
| ACT | 4.5V to 5.5V |
| Input Voltage (V_I) | 0V to V_{CC} |
| Output Voltage (V_O) | 0V to V_{CC} |
| Operating Temperature (T_A) | -40°C to +85°C |
| Minimum Input Edge Rate ($\Delta V/\Delta t$) | |
| AC Devices | |
| V_{IN} from 30% to 70% | |
| V_{CC} @ 3.3V, 4.5V, 5.5V | 125 mV/ns |
| Minimum Input Edge Rate ($\Delta V/\Delta t$) | |
| ACT Devices | |
| V_{IN} from 0.8V to 2.0V | |
| V_{CC} @ 4.5V, 5.5V | 125 mV/ns |

Note 1: Absolute maximum ratings are those values beyond which damage to the device may occur. The databook specifications should be met, with-out exception to ensure that the system design is reliable over its power supply, temperature, and output/input loading variables. Fairchild does not recommend operation of FACT™ circuits outside databook specifications.

DC Electrical Characteristics for AC

| Symbol | Parameter | V_{CC} (V) | $T_A = +25^\circ\text{C}$ | | $T_A = -40^\circ\text{C to } +85^\circ\text{C}$ | | Units | Conditions |
|-----------|--|-----------------|---------------------------|-------------------|---|-------------------|--|------------|
| | | | Typ | Guaranteed Limits | Typ | Guaranteed Limits | | |
| V_{IH} | Minimum HIGH Input Voltage | 3.0 | 1.5 | 2.1 | 2.1 | V | $V_{OUT} = 0.1V$ or $V_{CC} - 0.1V$ | |
| | | 4.5 | 2.25 | 3.15 | 3.15 | | | |
| | | 5.5 | 2.75 | 3.85 | 3.85 | | | |
| V_{IL} | Maximum LOW Input Voltage | 3.0 | 1.5 | 0.9 | 0.9 | V | $V_{OUT} = 0.1V$ or $V_{CC} - 0.1V$ | |
| | | 4.5 | 2.25 | 1.35 | 1.35 | | | |
| | | 5.5 | 2.75 | 1.65 | 1.65 | | | |
| V_{OH} | Minimum HIGH Output Voltage | 3.0 | 2.99 | 2.9 | 2.9 | V | $I_{OUT} = -50 \mu\text{A}$ | |
| | | 4.5 | 4.49 | 4.4 | 4.4 | | | |
| | | 5.5 | 5.49 | 5.4 | 5.4 | | | |
| | | 3.0 | | 2.56 | 2.46 | V | $I_{OH} = -12 \text{ mA}$ $I_{OH} = -24 \text{ mA}$ $I_{OH} = -24 \text{ mA (Note 2)}$ | |
| | | 4.5 | | 3.86 | 3.76 | | | |
| | | 5.5 | | 4.86 | 4.76 | | | |
| V_{OL} | Maximum LOW Output Voltage | 3.0 | 0.002 | 0.1 | 0.1 | V | $I_{OUT} = 50 \mu\text{A}$ | |
| | | 4.5 | 0.001 | 0.1 | 0.1 | | | |
| | | 5.5 | 0.001 | 0.1 | 0.1 | | | |
| | | 3.0 | | 0.36 | 0.44 | V | $I_{OL} = 12 \text{ mA}$ $I_{OL} = 24 \text{ mA}$ $I_{OL} = 24 \text{ mA (Note 2)}$ | |
| | | 4.5 | | 0.36 | 0.44 | | | |
| | | 5.5 | | 0.36 | 0.44 | | | |
| I_{OZ} | Maximum 3-STATE Leakage Current | 5.5 | | 0.50 | ± 5.0 | μA | V_I (OE) = V_{IL} , V_{IH} $V_I = V_{CC}$, GND $V_O = V_{CC}$, GND | |
| I_{IN} | Maximum Input Leakage Current (Note 3) | 5.5 | | ± 0.1 | ± 1.0 | μA | $V_I = V_{CC}$, GND | |
| I_{CC} | Max Quiescent Supply Current (Note 3) | 5.5 | | 8.0 | 80.0 | μA | $V_{IN} = V_{CC}$ or GND | |
| I_{OLD} | Minimum Dynamic | 5.5 | | | 75 | mA | $V_{OLD} = 1.65V$ Max | |
| I_{OHD} | Output Current (Note 4) | 5.5 | | | -75 | mA | $V_{OHD} = 3.85V$ Min | |

Note 2: All outputs loaded; thresholds associated with output under test.

Note 3: I_{IN} and I_{CC} @ 3.0V are guaranteed to be less than or equal to the respective limit @ 5.5V V_{CC} .

Note 4: Maximum test duration 2.0 millisecond; one output loaded at a time.

DC Electrical Characteristics for ACT

| Symbol | Parameter | V _{CC} (V) | T _A = +25°C | | T _A = -40°C to +85°C | Units | Conditions |
|------------------|---------------------------------|------------------------|------------------------|-------------------|---------------------------------|-------|---|
| | | | Typ | Guaranteed Limits | | | |
| V _{IH} | Minimum HIGH Input Voltage | 4.5 | 1.5 | 2.0 | 2.0 | V | V _{OUT} = 0.1V or V _{CC} - 0.1V |
| | | 5.5 | 1.5 | 2.0 | 2.0 | | |
| V _{IL} | Maximum LOW Input Voltage | 4.5 | 1.5 | 0.8 | 0.8 | V | V _{OUT} = 0.1V or V _{CC} - 0.1V |
| | | 5.5 | 1.5 | 0.8 | 0.8 | | |
| V _{OH} | Minimum HIGH Output Voltage | 4.5 | 4.49 | 4.4 | 4.4 | V | I _{OUT} = -50 μA |
| | | 5.5 | 5.49 | 5.4 | 5.4 | | |
| | | 4.5 | | 3.86 | 3.76 | V | V _{IN} = V _{IL} or V _{IH} I _{OH} = -24 mA I _{OH} = -24 mA (Note 5) |
| | | 5.5 | | 4.86 | 4.76 | | |
| V _{OL} | Maximum LOW Output Voltage | 4.5 | 0.001 | 0.1 | 0.1 | V | I _{OUT} = 50 μA |
| | | 5.5 | 0.001 | 0.1 | 0.1 | | |
| | | 4.5 | | 0.36 | 0.44 | V | V _{IN} = V _{IL} or V _{IH} I _{OH} = 24 mA I _{OH} = 24 mA (Note 5) |
| | | 5.5 | | 0.36 | 0.44 | | |
| I _{OZ} | Maximum 3-STATE Leakage Current | 5.5 | | ± 0.5 | ± 5.0 | μA | V _I = V _{IL} , V _{IH} V _O = V _{CC} , GND |
| I _{IN} | Maximum Input Leakage Current | 5.5 | | ± 0.1 | ± 1.0 | μA | V _I = V _{CC} , GND |
| I _{CCT} | Maximum I _{CC} /Input | 5.5 | 0.6 | | 1.5 | mA | V _I = V _{CC} - 2.1V |
| I _{CC} | Max Quiescent Supply Current | 5.5 | | 8.0 | 80.0 | μA | V _{IN} = V _{CC} or GND |
| I _{OLD} | Minimum Dynamic | 5.5 | | | 75 | mA | V _{OLD} = 1.65V Max |
| I _{OHD} | Output Current (Note 6) | | | | -75 | mA | V _{OHD} = 3.85V Min |

Note 5: All outputs loaded; thresholds associated with output under test.

Note 6: Maximum test duration 2.0 millisecond; one output loaded at a time.

| AC Electrical Characteristics for AC | | | | | | | | |
|--------------------------------------|---------------------|------------------------------------|--|-----|------|---|------|-------|
| Symbol | Parameter | V _{CC} (V) (Note 7) | T _A = +25°C C _L = 50 pF | | | T _A = -40°C to +85°C C _L = 50 pF | | Units |
| | | | Min | Typ | Max | Min | Max | |
| t _{PLH} | Propagation Delay | 3.3 | 2.0 | 6.3 | 9.4 | 2.0 | 10.8 | ns |
| | Data to Output | 5.0 | 1.6 | 4.6 | 6.5 | 1.6 | 7.1 | |
| t _{PHL} | Propagation Delay | 3.3 | 2.4 | 5.7 | 10.7 | 2.4 | 11.8 | ns |
| | Data to Output | 5.0 | 2.0 | 4.3 | 7.0 | 2.0 | 7.9 | |
| t _{PZH} | Output Enable Time | 3.3 | 2.2 | 6.2 | 10 | 2.2 | 11.5 | ns |
| | | 5.0 | 1.7 | 4.6 | 6.7 | 1.7 | 7.5 | |
| t _{PZL} | Output Enable Time | 3.3 | 2.9 | 6.4 | 13.0 | 2.9 | 14.6 | ns |
| | | 5.0 | 2.2 | 4.7 | 8.1 | 2.2 | 9.0 | |
| t _{PHZ} | Output Disable Time | 3.3 | 3.1 | 5.5 | 8.4 | 3.1 | 9.1 | ns |
| | | 5.0 | 1.9 | 3.9 | 7.8 | 1.9 | 8.4 | |
| t _{PLZ} | Output Disable Time | 3.3 | 2.4 | 4.7 | 8.1 | 2.4 | 8.8 | ns |
| | | 5.0 | 1.7 | 3.6 | 7.2 | 1.7 | 7.6 | |

Note 7: Voltage Range 5.0 is 5.0V ± 0.5V.
Voltage Range 3.3 is 3.3V ± 0.3V.

| AC Electrical Characteristics for ACT | | | | | | | | |
|---------------------------------------|-------------------|------------------------------------|--|-----|-----|---|-----|-------|
| Symbol | Parameter | V _{CC} (V) (Note 8) | T _A = +25°C C _L = 50 pF | | | T _A = -40°C to +85°C C _L = 50 pF | | Units |
| | | | Min | Typ | Max | Min | Max | |
| t _{PLH} | Propagation Delay | 5.0 | 3.0 | 5.2 | 7.3 | 3.0 | 7.8 | ns |
| t _{PHL} | Data to Output | | 2.5 | 4.8 | 6.8 | 2.5 | 7.3 | |
| t _{PZH} | Output Enable | 5.0 | 2.5 | 5.0 | 7.4 | 2.5 | 7.9 | ns |
| t _{PZL} | Time | | 2.7 | 4.6 | 7.5 | 2.7 | 8.0 | |
| t _{PHZ} | Output Disable | 5.0 | 2.3 | 5.0 | 7.9 | 2.3 | 8.2 | ns |
| t _{PLZ} | Time | | 2.0 | 4.6 | 7.4 | 2.0 | 7.9 | |

Note 8: Voltage Range 5.0 is 5.0V ± 0.5V.

| Capacitance | | | | | |
|------------------|-------------------------------|------------|-------|------------------------|------------------------|
| Symbol | Parameter | Typ | Units | Conditions | |
| C _{IN} | Input Pin Capacitance | 4.5 | pF | V _{CC} = 5.0V | |
| C _{OUT} | Output Pin Capacitance | 12 | pF | V _{CC} = 5.0V | |
| C _{PD} | Power Dissipation Capacitance | 74AC16244 | 35 | pF | V _{CC} = 5.0V |
| | | 74ACT16244 | 30 | | |

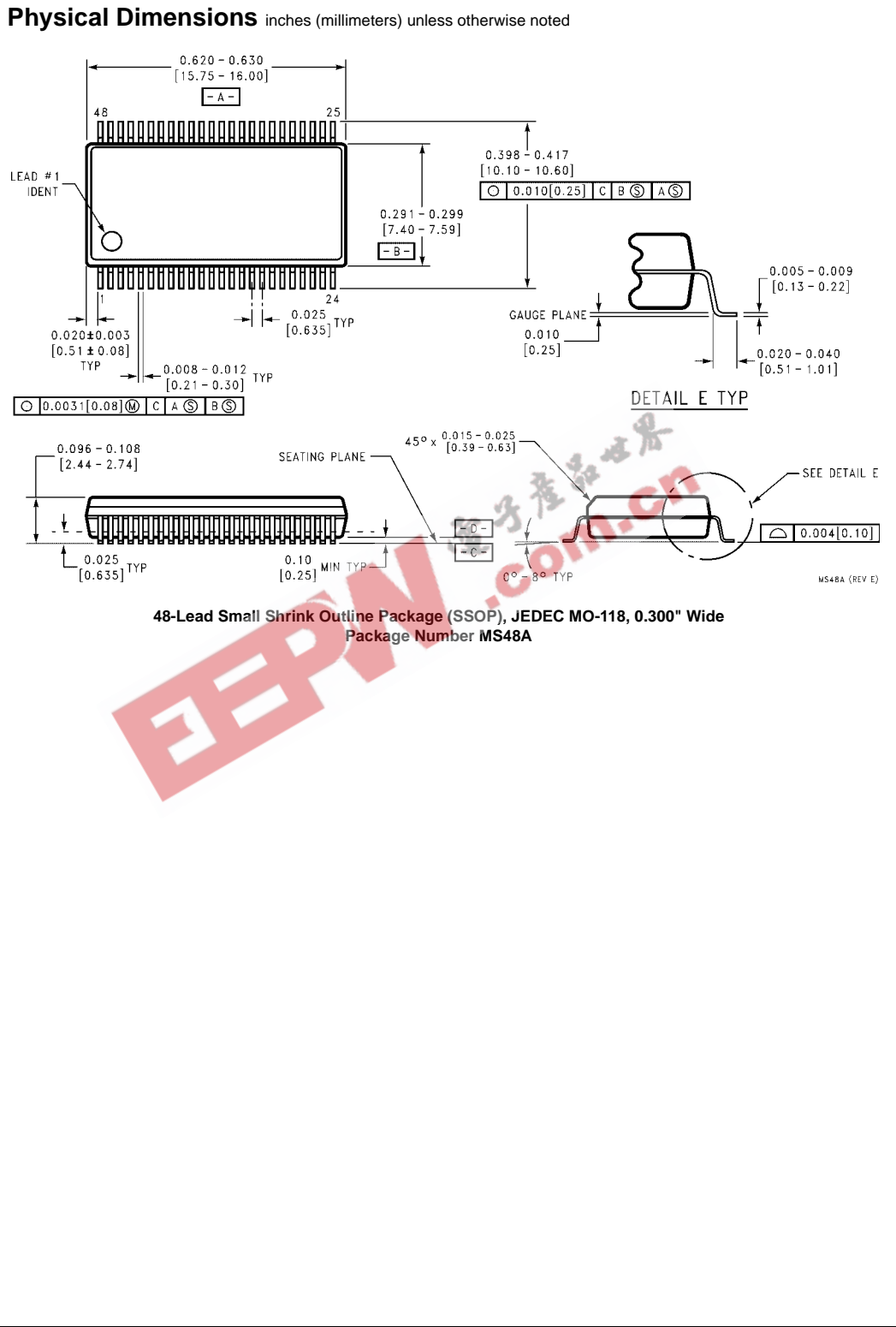

Physical Dimensions inches (millimeters) unless otherwise noted (Continued)

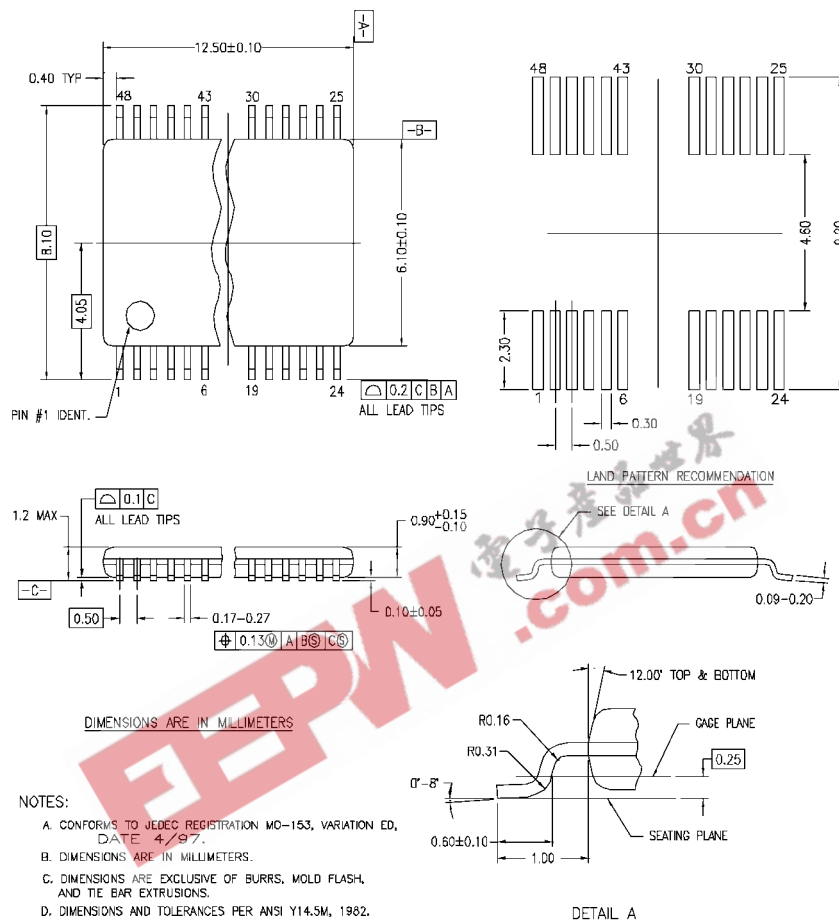

MTD48REVC

48-Lead Thin Shrink Small Outline Package (TSSOP), JEDEC MO-153, 6.1mm Wide Package Number MTD48

Fairchild does not assume any responsibility for use of any circuitry described, no circuit patent licenses are implied and Fairchild reserves the right at any time without notice to change said circuitry and specifications.

LIFE SUPPORT POLICY

FAIRCHILD'S PRODUCTS ARE NOT AUTHORIZED FOR USE AS CRITICAL COMPONENTS IN LIFE SUPPORT DEVICES OR SYSTEMS WITHOUT THE EXPRESS WRITTEN APPROVAL OF THE PRESIDENT OF FAIRCHILD SEMICONDUCTOR CORPORATION. As used herein:

- Life support devices or systems are devices or systems which, (a) are intended for surgical implant into the body, or (b) support or sustain life, and (c) whose failure to perform when properly used in accordance with instructions for use provided in the labeling, can be reasonably expected to result in a significant injury to the user.
- A critical component in any component of a life support device or system whose failure to perform can be reasonably expected to cause the failure of the life support device or system, or to affect its safety or effectiveness.

www.fairchildsemi.com