

# DATA SHEET

## 74ALVT162823

18-bit bus-interface D-type flip-flop  
with reset and enable  
with  $30\Omega$  termination resistors (3-State)

Product specification

1998 Aug 27

IC24 Data Handbook

## 2.5V/3.3V 18-bit bus-interface D-type flip-flop with reset and enable with 30Ω termination resistors (3-State)

74ALVT162823

### FEATURES

- Two sets of high speed parallel registers with positive edge-triggered D-type flip-flops
- 5V I/O Compatible
- Ideal where high speed, light loading, or increased fan-in are required with MOS microprocessors
- Live insertion/extraction permitted
- Power-up 3-State
- Power-up Reset
- Output capability: +12mA/-12mA
- Latch-up protection exceeds 500mA per Jedec Std 17
- ESD protection exceeds 2000 V per MIL STD 883 Method 3015 and 200 V per Machine Model
- Bus hold data inputs eliminate the need for external pull-up resistors to hold unused inputs
- Outputs include series resistance of 30Ω making external termination resistors unnecessary

### DESCRIPTION

The 74ALVT162823 18-bit bus interface register is designed to eliminate the extra packages required to buffer existing registers and provide extra data width for wider data/address paths of buses carrying parity.

The 74ALVT162823 has two 9-bit wide buffered registers with Clock Enable ( $\overline{nCE}$ ) and Master Reset ( $\overline{nMR}$ ) which are ideal for parity bus interfacing in high microprogrammed systems.

The registers are fully edge-triggered. The state of each D input, one set-up time before the Low-to-High clock transition is transferred to the corresponding flip-flop's Q output.

The 74ALVT162823 is designed with 30Ω series resistance in both the pull-up and pull-down output structures. This design reduces line noise in applications such as memory address drivers, clock drivers, and bus receivers/transmitters.

### QUICK REFERENCE DATA

SYMBOL	PARAMETER	CONDITIONS $T_{amb} = 25^{\circ}\text{C}; \text{GND} = 0\text{V}$	TYPICAL		UNIT
			2.5V	3.3V	
$t_{PLH}$ $t_{PHL}$	Propagation delay nCP to nQx	$C_L = 50\text{pF}$	4.2 3.4	3.0 2.8	ns
$C_{IN}$	Input capacitance	$V_I = 0\text{V}$ or $V_{CC}$	3	3	pF
$C_{OUT}$	Output capacitance	$V_{I/O} = 0\text{V}$ or 3.0V	9	9	pF
$I_{CCZ}$	Total supply current	Outputs disabled	40	70	μA

### ORDERING INFORMATION

PACKAGES	TEMPERATURE RANGE	OUTSIDE NORTH AMERICA	NORTH AMERICA	DWG NUMBER
56-Pin Plastic SSOP Type III	-40°C to +85°C	74ALVT162823 DL	AV162823 DL	SOT371-1
56-Pin Plastic TSSOP Type II	-40°C to +85°C	74ALVT162823 DGG	AV162823 DGG	SOT364-1

### PIN DESCRIPTION

PIN NUMBER	SYMBOL	FUNCTION
2, 27	1OE, 2OE	Output enable input (active-Low)
54, 52, 51, 49, 48, 47, 45, 44, 43 42, 41, 40, 38, 37, 36, 34, 33, 31	1D0-1D8 2D0-2D8	Data inputs
3, 5, 6, 8, 9, 10, 12, 13, 14 15, 16, 17, 19, 20, 21, 23, 24, 26	1Q0-1Q8 2Q0-2Q8	Data outputs
56, 29	1CP, 2CP	Clock pulse input (active rising edge)
55, 30	1CE, 2CE	Clock enable input (active-Low)
1, 28	1MR, 2MR	Master reset input (active-Low)
4, 11, 18, 25, 32, 39, 46, 53	GND	Ground (0V)
7, 22, 35, 50	$V_{CC}$	Positive supply voltage

2.5V/3.3V 18-bit bus-interface D-type flip-flop with reset and enable with 30Ω termination resistors (3-State)

74ALVT162823

PIN CONFIGURATION

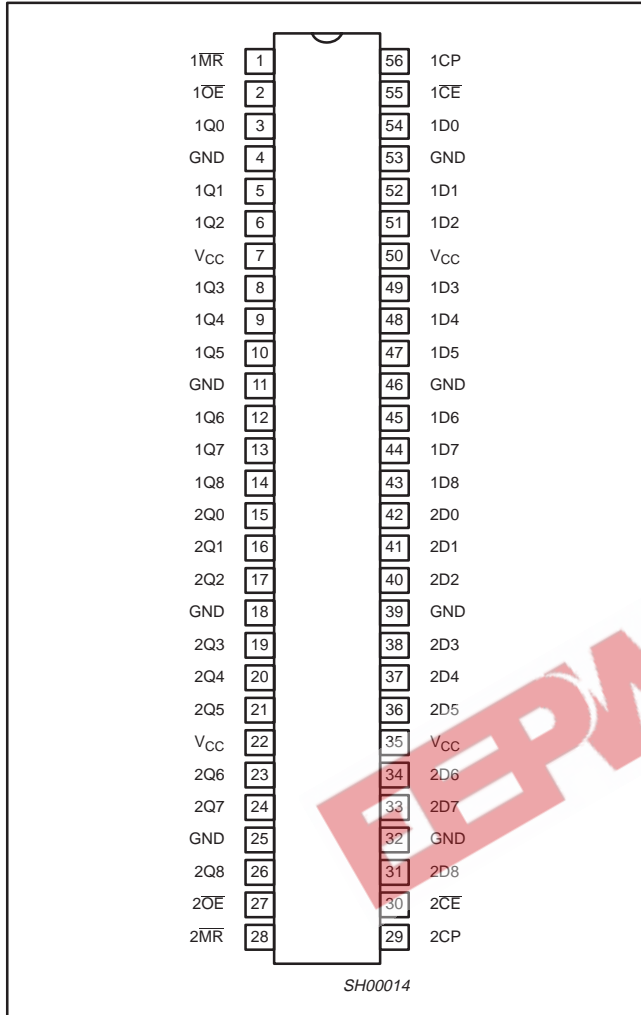

LOGIC SYMBOL (IEEE/IEC)

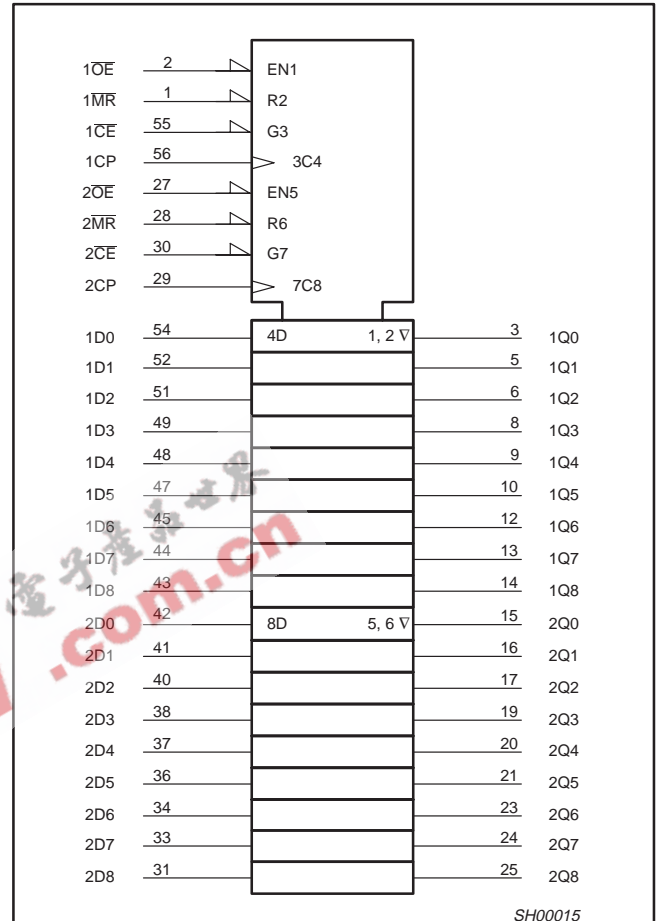

LOGIC DIAGRAM

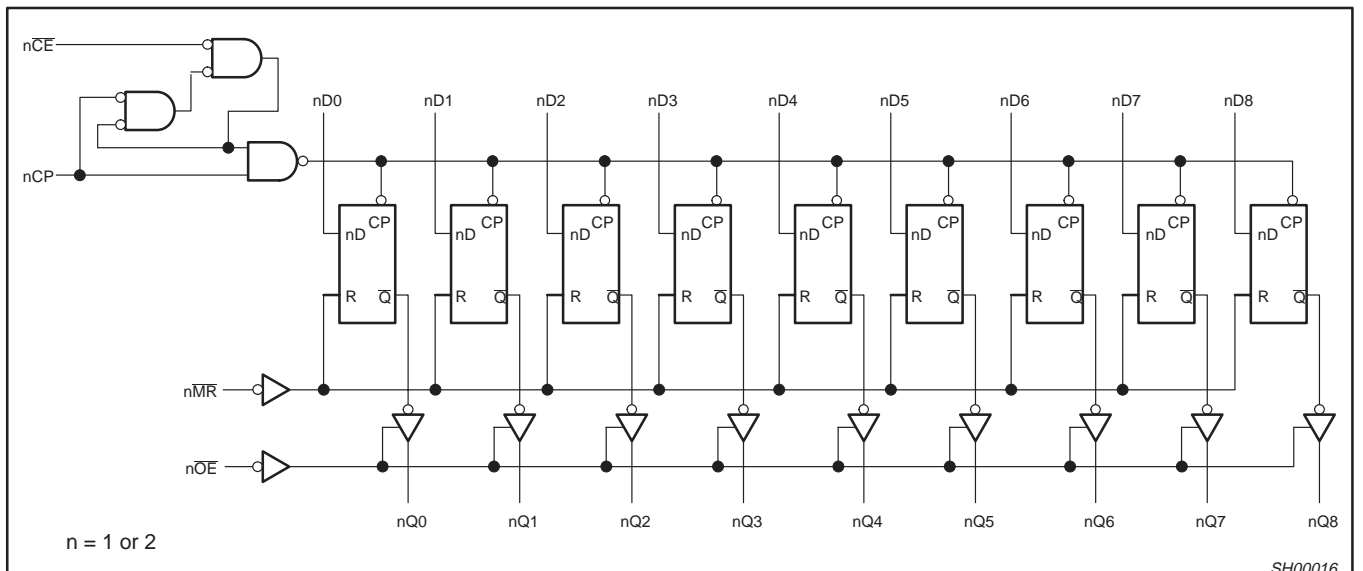

2.5V/3.3V 18-bit bus-interface D-type flip-flop with reset and enable with 30Ω termination resistors (3-State)

74ALVT162823

FUNCTION TABLE

INPUTS					OUTPUTS	OPERATING MODE
nOE	nMR	nCE	nCP	nDx	nQ0 – nQ8	
L	L	X	X	X	L	Clear
L	H	L	↑	h	H	Load and read data
L	H	L	↑	l	L	
L	H	H	↑	X	NC	Hold
H	X	X	X	X	Z	High impedance

H = High voltage level  
 h = High voltage level one set-up time prior to the Low-to-High clock transition  
 L = Low voltage level  
 l = Low voltage level one set-up time prior to the Low-to-High clock transition  
 NC= No change  
 X = Don't care  
 Z = High impedance "off" state  
 ↑ = Low to High clock transition  
 ↑ = Not a Low-to-High clock transition

SCHEMATIC OF EACH OUTPUT

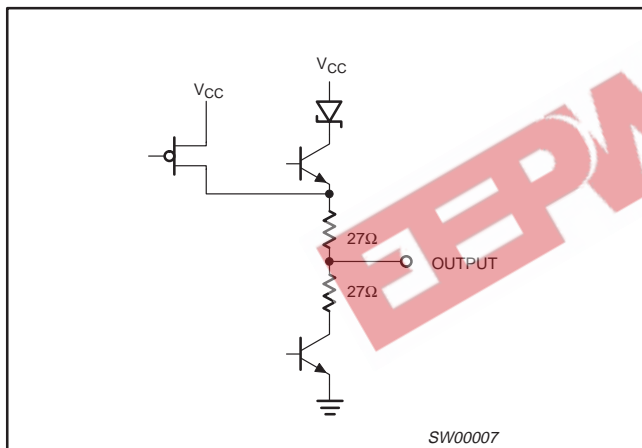

BUS HOLD CIRCUIT

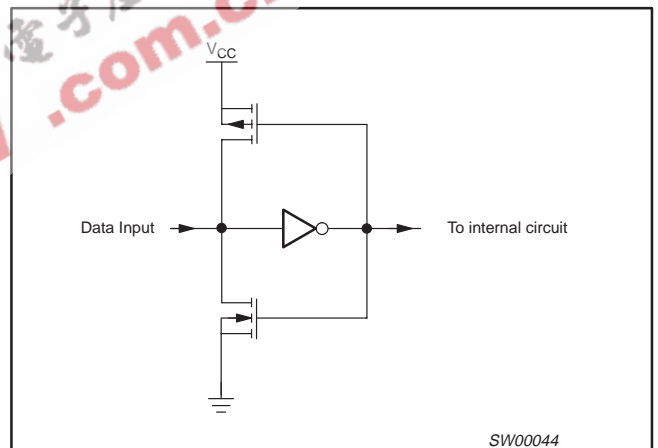

ABSOLUTE MAXIMUM RATINGS<sup>1, 2</sup>

SYMBOL	PARAMETER	CONDITIONS	RATING	UNIT
V <sub>CC</sub>	DC supply voltage		-0.5 to +4.6	V
I <sub>IK</sub>	DC input diode current	V <sub>I</sub> < 0	-50	mA
V <sub>I</sub>	DC input voltage <sup>3</sup>		-0.5 to +7.0	V
I <sub>OK</sub>	DC output diode current	V <sub>O</sub> < 0	-50	mA
V <sub>OUT</sub>	DC output voltage <sup>3</sup>	Output in Off or High state	-0.5 to +7.0	V
I <sub>OUT</sub>	DC output current	Output in Low state	128	mA
		Output in High state	-64	
T <sub>stg</sub>	Storage temperature range		-65 to +150	°C

NOTES:

- Stresses beyond those listed may cause permanent damage to the device. These are stress ratings only and functional operation of the device at these or any other conditions beyond those indicated under "recommended operating conditions" is not implied. Exposure to absolute-maximum-rated conditions for extended periods may affect device reliability.
- The performance capability of a high-performance integrated circuit in conjunction with its thermal environment can create junction temperatures which are detrimental to reliability. The maximum junction temperature of this integrated circuit should not exceed 150°C.
- The input and output negative voltage ratings may be exceeded if the input and output clamp current ratings are observed.

## 2.5V/3.3V 18-bit bus-interface D-type flip-flop with reset and enable with 30Ω termination resistors (3-State)

74ALVT162823

### RECOMMENDED OPERATING CONDITIONS

SYMBOL	PARAMETER	2.5V RANGE LIMITS		3.3V RANGE LIMITS		UNIT
		MIN	MAX	MIN	MAX	
$V_{CC}$	DC supply voltage	2.3	2.7	3.0	3.6	V
$V_I$	Input voltage	0	5.5	0	5.5	V
$V_{IH}$	High-level input voltage	1.7		2.0		V
$V_{IL}$	Input voltage		0.7		0.8	V
$I_{OH}$	High-level output current		-8		-12	mA
$I_{OL}$	Low-level output current		12		12	mA
$\Delta t/\Delta v$	Input transition rise or fall rate; Outputs enabled		10		10	ns/V
$T_{amb}$	Operating free-air temperature range	-40	+85	-40	+85	°C

### DC ELECTRICAL CHARACTERISTICS (3.3V ± 0.3V RANGE)

SYMBOL	PARAMETER	TEST CONDITIONS	LIMITS			UNIT
			Temp = -40°C to +85°C			
			MIN	TYP <sup>1</sup>	MAX	
$V_{IK}$	Input clamp voltage	$V_{CC} = 3.0V; I_{IK} = -18mA$		-0.85	-1.2	V
$V_{OH}$	High-level output voltage	$V_{CC} = 3.0V; I_{OH} = -12mA$	2.0	2.3		V
$V_{OL}$	Low-level output voltage	$V_{CC} = 3.0V; I_{OL} = 12mA$		0.5	0.8	V
$V_{RST}$	Power-up output low voltage <sup>6</sup>	$V_{CC} = 3.6V; I_O = 1mA; V_I = V_{CC}$ or GND			0.55	V
$I_I$	Input leakage current	$V_{CC} = 3.6V; V_I = V_{CC}$ or GND	Control pins	0.1	±1	μA
		$V_{CC} = 0$ or 3.6V; $V_I = 5.5V$		0.1	10	
		$V_{CC} = 3.6V; V_I = 5.5V$	Data pins <sup>4</sup>	0.1	10	μA
		$V_{CC} = 3.6V; V_I = V_{CC}$		0.5	1	
		$V_{CC} = 3.6V; V_I = 0$		0.1	-5	
$I_{OFF}$	Off current	$V_{CC} = 0V; V_I$ or $V_O = 0$ to 4.5V		0.1	±100	μA
$I_{HOLD}$	Bus Hold current D inputs <sup>7</sup>	$V_{CC} = 3V; V_I = 0.8V$	75	130	μA	
		$V_{CC} = 3V; V_I = 2.0V$	-75	-140		
		$V_{CC} = 0V$ to 3.6V; $V_{CC} = 3.6V$	±500			
$I_{EX}$	Current into an output in the High state when $V_O > V_{CC}$	$V_O = 5.5V; V_{CC} = 3.0V$		10	125	μA
$I_{PU/PD}$	Power up/down 3-State output current <sup>3</sup>	$V_{CC} \leq 1.2V; V_O = 0.5V$ to $V_{CC}; V_I = GND$ or $V_{CC}$ OE/OE = Don't care		1	±100	μA
$I_{OZH}$	3-State output High current	$V_{CC} = 3.6V; V_O = 3.0V; V_I = V_{IL}$ or $V_{IH}$		0.5	5	μA
$I_{OZL}$	3-State output Low current	$V_{CC} = 3.6V; V_O = 0.5V; V_I = V_{IL}$ or $V_{IH}$		0.5	-5	μA
$I_{CCH}$	Quiescent supply current	$V_{CC} = 3.6V$ ; Outputs High, $V_I = GND$ or $V_{CC}, I_O = 0$		0.05	0.1	mA
$I_{CCL}$		$V_{CC} = 3.6V$ ; Outputs Low, $V_I = GND$ or $V_{CC}, I_O = 0$		3.9	5.5	
$I_{CCZ}$		$V_{CC} = 3.6V$ ; Outputs Disabled; $V_I = GND$ or $V_{CC}, I_O = 0^5$		0.06	0.1	
$\Delta I_{CC}$	Additional supply current per input pin <sup>2</sup>	$V_{CC} = 3V$ to 3.6V; One input at $V_{CC}-0.6V$ , Other inputs at $V_{CC}$ or GND		0.04	0.4	mA

#### NOTES:

- All typical values are at  $V_{CC} = 3.3V$  and  $T_{amb} = 25^\circ C$ .
- This is the increase in supply current for each input at the specified voltage level other than  $V_{CC}$  or GND
- This parameter is valid for any  $V_{CC}$  between 0V and 1.2V with a transition time of up to 10msec. From  $V_{CC} = 1.2V$  to  $V_{CC} = 3.3V \pm 0.3V$  a transition time of 100μsec is permitted. This parameter is valid for  $T_{amb} = 25^\circ C$  only.
- Unused pins at  $V_{CC}$  or GND.
- $I_{CCZ}$  is measured with outputs pulled up to  $V_{CC}$  or pulled down to ground.
- For valid test results, data must not be loaded into the flip-flops (or latches) after applying power.
- This is the bus hold overdrive current required to force the input to the opposite logic state.

## 2.5V/3.3V 18-bit bus-interface D-type flip-flop with reset and enable with 30Ω termination resistors (3-State)

74ALVT162823

### AC CHARACTERISTICS (3.3V ± 0.3V RANGE)

GND = 0V,  $t_R = t_F = 2.5\text{ns}$ ,  $C_L = 50\text{pF}$ ,  $R_L = 500\Omega$ 

SYMBOL	PARAMETER	WAVEFORM	LIMITS			UNIT
			$T_{\text{amb}} = -40^{\circ}\text{C}$ to $+85^{\circ}\text{C}$ $V_{\text{CC}} = +3.3\text{V} \pm 0.3\text{V}$			
			MIN	TYP	MAX	
$f_{\text{MAX}}$	Maximum clock frequency	1				MHz
$t_{\text{PLH}}$ $t_{\text{PHL}}$	Propagation delay nCP to nQx	1	1.8 1.8	3.0 2.8	4.7 4.0	ns
$t_{\text{PHL}}$	Propagation delay nMR to nQx	2	1.8	2.8	4.0	ns
$t_{\text{PZH}}$ $t_{\text{PZL}}$	Output enable time to High and Low level	4 5	1.9 1.6	3.5 2.6	5.7 3.8	ns
$t_{\text{PHZ}}$ $t_{\text{PLZ}}$	Output disable time from High and Low level	4 5	1.9 1.5	3.4 2.5	5.2 3.8	ns

### AC SETUP REQUIREMENTS (3.3V ± 0.3V RANGE)

GND = 0V,  $t_R = t_F = 2.5\text{ns}$ ,  $C_L = 50\text{pF}$ ,  $R_L = 500\Omega$ 

SYMBOL	PARAMETER	WAVEFORM	LIMITS		UNIT
			$T_{\text{amb}} = -40$ to $+85^{\circ}\text{C}$ $V_{\text{CC}} = +3.3\text{V} \pm 0.3\text{V}$		
			MIN	TYP	
$t_{\text{s}}(\text{H})$ $t_{\text{s}}(\text{L})$	Setup time, High or Low nDx to nCP	3	1.0 1.2	0.6 0.7	ns
$t_{\text{h}}(\text{H})$ $t_{\text{h}}(\text{L})$	Hold time, High or Low nDx to nCP	3	0.1 0.1	-0.8 -0.6	ns
$t_{\text{w}}(\text{H})$ $t_{\text{w}}(\text{L})$	nCP pulse width High or Low	1	1.5 2.5	0.7 1.7	ns
$t_{\text{s}}(\text{H})$ $t_{\text{s}}(\text{L})$	Setup time, High or Low nCE to nCP	3	1.0 0.5	0.2 -0.5	ns
$t_{\text{h}}(\text{H})$ $t_{\text{h}}(\text{L})$	Hold time, High or Low nCE to nCP	3	1.0 1.0	0.5 -0.1	ns
$t_{\text{w}}(\text{L})$	nMR pulse width, Low	2	2.0	1.5	ns
$t_{\text{rec}}$	Recovery time nMR to nCP	2	2.0	1.4	ns

## 2.5V/3.3V 18-bit bus-interface D-type flip-flop with reset and enable with 30Ω termination resistors (3-State)

74ALVT162823

### DC ELECTRICAL CHARACTERISTICS (2.5V ± 0.2V RANGE)

SYMBOL	PARAMETER	TEST CONDITIONS	LIMITS			UNIT
			Temp = -40°C to +85°C			
			MIN	TYP <sup>1</sup>	MAX	
V <sub>IK</sub>	Input clamp voltage	V <sub>CC</sub> = 2.3V; I <sub>IK</sub> = -18mA		-0.85	-1.2	V
V <sub>OH</sub>	High-level output voltage	V <sub>CC</sub> = 2.3V; I <sub>OH</sub> = -8mA	1.7	2.5		V
V <sub>OL</sub>	Low-level output voltage	V <sub>CC</sub> = 2.3V; I <sub>OL</sub> = 12mA		0.3	0.5	V
V <sub>RST</sub>	Power-up output low voltage <sup>7</sup>	V <sub>CC</sub> = 2.7V; I <sub>O</sub> = 1mA; V <sub>I</sub> = V <sub>CC</sub> or GND		0.2	0.55	V
I <sub>I</sub>	Input leakage current	V <sub>CC</sub> = 2.7V; V <sub>I</sub> = GND	Control pins	0.1	±1	μA
		V <sub>CC</sub> = 2.7V; V <sub>I</sub> = 5.5V		0.1	10	
		V <sub>CC</sub> = 3.6V; V <sub>I</sub> = 5.5V	Data pins <sup>4</sup>	0.1	10	μA
		V <sub>CC</sub> = 3.6V; V <sub>I</sub> = V <sub>CC</sub>		0.5	1	
		V <sub>CC</sub> = 3.6V; V <sub>I</sub> = 0		0.1	-5	
I <sub>OFF</sub>	Off current	V <sub>CC</sub> = 0V; V <sub>I</sub> or V <sub>O</sub> = 0 to 4.5V		0.1	±100	μA
I <sub>HOLD</sub>	Bus Hold current D inputs <sup>6</sup>	V <sub>CC</sub> = 2.5V; V <sub>I</sub> = 0.7V		100		μA
		V <sub>CC</sub> = 2.5V; V <sub>I</sub> = 1.7V		-70		μA
I <sub>EX</sub>	Current into an output in the High state when V <sub>O</sub> > V <sub>CC</sub>	V <sub>O</sub> = 5.5V; V <sub>CC</sub> = 2.5V		10	125	μA
I <sub>PU/PD</sub>	Power up/down 3-State output current <sup>3</sup>	V <sub>CC</sub> ≤ 1.2V; V <sub>O</sub> = 0.5V to V <sub>CC</sub> ; V <sub>I</sub> = GND or V <sub>CC</sub> ; OE/OE = Don't care		1	±100	μA
I <sub>OZH</sub>	3-State output High current	V <sub>CC</sub> = 2.7V; V <sub>O</sub> = 2.3V; V <sub>I</sub> = V <sub>IL</sub> or V <sub>IH</sub>		0.5	5	μA
I <sub>OZL</sub>	3-State output Low current	V <sub>CC</sub> = 2.7V; V <sub>O</sub> = 0.5V; V <sub>I</sub> = V <sub>IL</sub> or V <sub>IH</sub>		0.5	-5	μA
I <sub>CCH</sub>	Quiescent supply current	V <sub>CC</sub> = 2.7V; Outputs High, V <sub>I</sub> = GND or V <sub>CC</sub> , I <sub>O</sub> = 0		0.04	0.1	mA
I <sub>CCL</sub>		V <sub>CC</sub> = 2.7V; Outputs Low, V <sub>I</sub> = GND or V <sub>CC</sub> , I <sub>O</sub> = 0		2.7	4.5	
I <sub>CCZ</sub>		V <sub>CC</sub> = 2.7V; Outputs Disabled; V <sub>I</sub> = GND or V <sub>CC</sub> , I <sub>O</sub> = 0 <sup>5</sup>		0.04	0.1	
ΔI <sub>CC</sub>	Additional supply current per input pin <sup>2</sup>	V <sub>CC</sub> = 2.3V to 2.7V; One input at V <sub>CC</sub> -0.6V, Other inputs at V <sub>CC</sub> or GND		0.04	0.4	mA

#### NOTES:

- All typical values are at V<sub>CC</sub> = 2.5V and T<sub>amb</sub> = 25°C.
- This is the increase in supply current for each input at the specified voltage level other than V<sub>CC</sub> or GND
- This parameter is valid for any V<sub>CC</sub> between 0V and 1.2V with a transition time of up to 10msec. From V<sub>CC</sub> = 1.2V to V<sub>CC</sub> = 2.5V ± 0.2V a transition time of 100μsec is permitted. This parameter is valid for T<sub>amb</sub> = 25°C only.
- Unused pins at V<sub>CC</sub> or GND.
- I<sub>CCZ</sub> is measured with outputs pulled up to V<sub>CC</sub> or pulled down to ground.
- Not guaranteed.
- For valid test results, data must not be loaded into the flip-flops (or latches) after applying power.

## 2.5V/3.3V 18-bit bus-interface D-type flip-flop with reset and enable with 30Ω termination resistors (3-State)

74ALVT162823

### AC CHARACTERISTICS (2.5V ± 0.2V RANGE)

GND = 0V,  $t_R = t_F = 2.5\text{ns}$ ,  $C_L = 50\text{pF}$ ,  $R_L = 500\Omega$ 

SYMBOL	PARAMETER	WAVEFORM	LIMITS			UNIT
			$T_{\text{amb}} = -40^{\circ}\text{C}$ to $+85^{\circ}\text{C}$ $V_{\text{CC}} = +2.5\text{V} \pm 0.2\text{V}$			
			MIN	TYP	MAX	
$f_{\text{MAX}}$	Maximum clock frequency	1				MHz
$t_{\text{PLH}}$ $t_{\text{PHL}}$	Propagation delay nCP to nQx	1	2.5 2.0	4.2 3.4	6.3 5.0	ns
$t_{\text{PHL}}$	Propagation delay nMR to nQx	2	2.0	3.4	4.6	ns
$t_{\text{PZH}}$ $t_{\text{PZL}}$	Output enable time to High and Low level	4 5	3.0 2.0	4.8 3.2	7.6 5.2	ns
$t_{\text{PHZ}}$ $t_{\text{PLZ}}$	Output disable time from High and Low level	4 5	2.5 2.0	4.4 3.3	6.7 5.2	ns

### AC SETUP REQUIREMENTS (2.5V ± 0.2V RANGE)

GND = 0V,  $t_R = t_F = 2.5\text{ns}$ ,  $C_L = 50\text{pF}$ ,  $R_L = 500\Omega$ 

SYMBOL	PARAMETER	WAVEFORM	LIMITS		UNIT
			$T_{\text{amb}} = -40$ to $+85^{\circ}\text{C}$ $V_{\text{CC}} = +2.5\text{V} \pm 0.2\text{V}$		
			MIN	TYP	
$t_{\text{S}}(\text{H})$ $t_{\text{S}}(\text{L})$	Setup time, High or Low nDx to nCP	3	1.0 2.0	0.6 1.4	ns
$t_{\text{H}}(\text{H})$ $t_{\text{H}}(\text{L})$	Hold time, High or Low nDx to nCP	3	0.1 0.1	-1.5 -0.6	ns
$t_{\text{W}}(\text{H})$ $t_{\text{W}}(\text{L})$	nCP pulse width High or Low	1	2.0 3.0	0.8 2.1	ns
$t_{\text{S}}(\text{H})$ $t_{\text{S}}(\text{L})$	Setup time, High or Low nCE to nCP	3	1.0 0.5	0.2 -0.2	ns
$t_{\text{H}}(\text{H})$ $t_{\text{H}}(\text{L})$	Hold time, High or Low nCE to nCP	3	1.0 1.0	0.2 -0.1	ns
$t_{\text{W}}(\text{L})$	nMR pulse width, Low	2	2.5	1.6	ns
$t_{\text{rec}}$	Recovery time nMR to nCP	2	2.3	1.7	ns



# 2.5V/3.3V 18-bit bus-interface D-type flip-flop with reset and enable with 30Ω termination resistors (3-State)

74ALVT162823

## AC WAVEFORMS

For all waveforms,  $V_M = 1.5V$  or  $V_{CC}/2$  whichever is less

The shaded areas indicate when the input is permitted to change for predictable output performance.

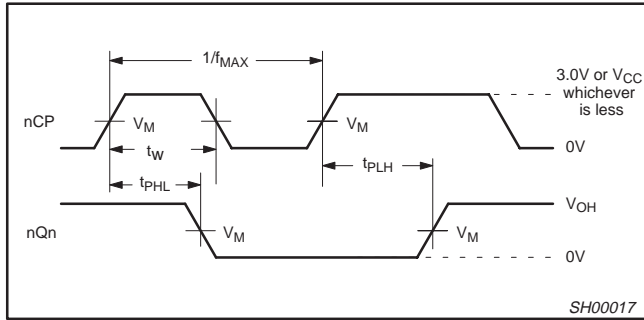

**Waveform 1. Propagation Delay, Clock Input to Output, Clock Pulse Width, and Maximum Clock Frequency**

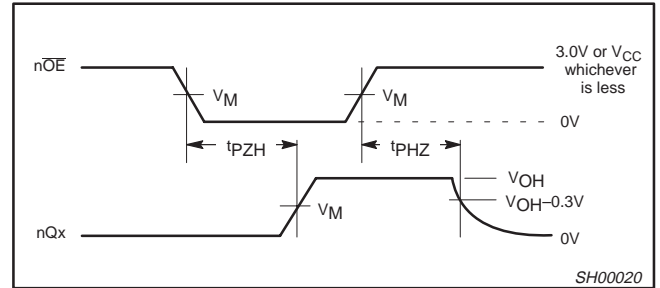

**Waveform 4. 3-State Output Enable Time to High Level and Output Disable Time from High Level**

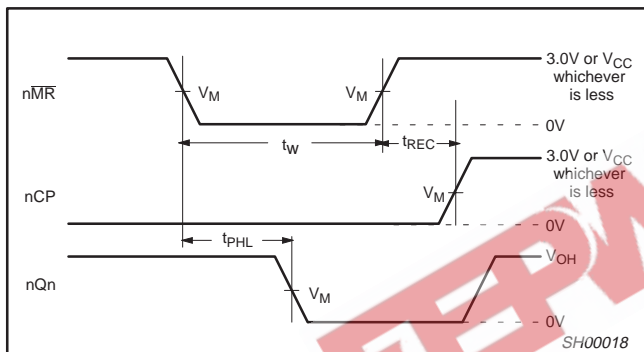

**Waveform 2. Master Reset Pulse Width, Master Reset to Output Delay and Master Reset to Clock Recovery Time**

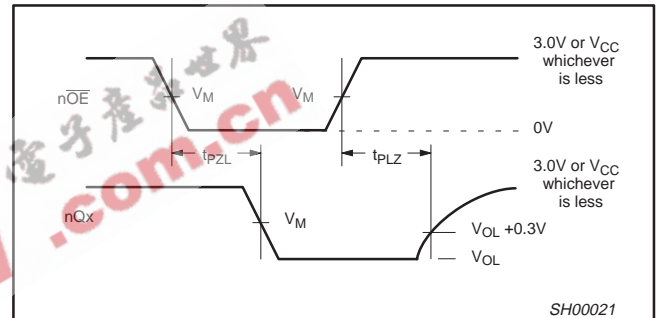

**Waveform 5. 3-State Output Enable Time to Low Level and Output Disable Time from Low Level**

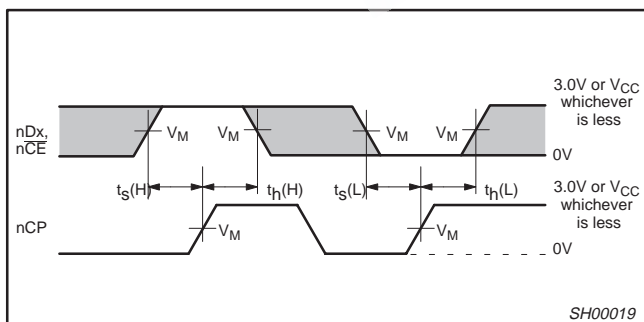

**Waveform 3. Data Setup and Hold Times**

2.5V/3.3V 18-bit bus-interface D-type flip-flop with reset and enable with 30Ω termination resistors (3-State)

74ALVT162823

TEST CIRCUIT AND WAVEFORM

**Test Circuit for 3-State Outputs**

**SWITCH POSITION**

TEST	SWITCH
$t_{PHZ}/t_{PZH}$	GND
$t_{PLZ}/t_{PZL}$	6V or $V_{CC} \times 2$
$t_{PLH}/t_{PHL}$	open

**DEFINITIONS**

$R_L$  = Load resistor; see AC CHARACTERISTICS for value.

$C_L$  = Load capacitance includes jig and probe capacitance; see AC CHARACTERISTICS for value.

$R_T$  = Termination resistance should be equal to  $Z_{OUT}$  of pulse generators.

**$V_M = 1.5V$  or  $V_{CC} / 2$ , whichever is less**  
**Input Pulse Definition**

FAMILY	INPUT PULSE REQUIREMENTS				
	Amplitude	Rep. Rate	$t_W$	$t_R$	$t_F$
74ALVT16	3.0V or $V_{CC}$ whichever is less	$\leq 10\text{MHz}$	500ns	$\leq 2.5\text{ns}$	$\leq 2.5\text{ns}$

SW00162

18-bit bus-interface D-type flip-flop with reset and enable with 30Ω termination resistors (3-State)

74ALVT162823

SSOP56: plastic shrink small outline package; 56 leads; body width 7.5 mm

SOT371-1

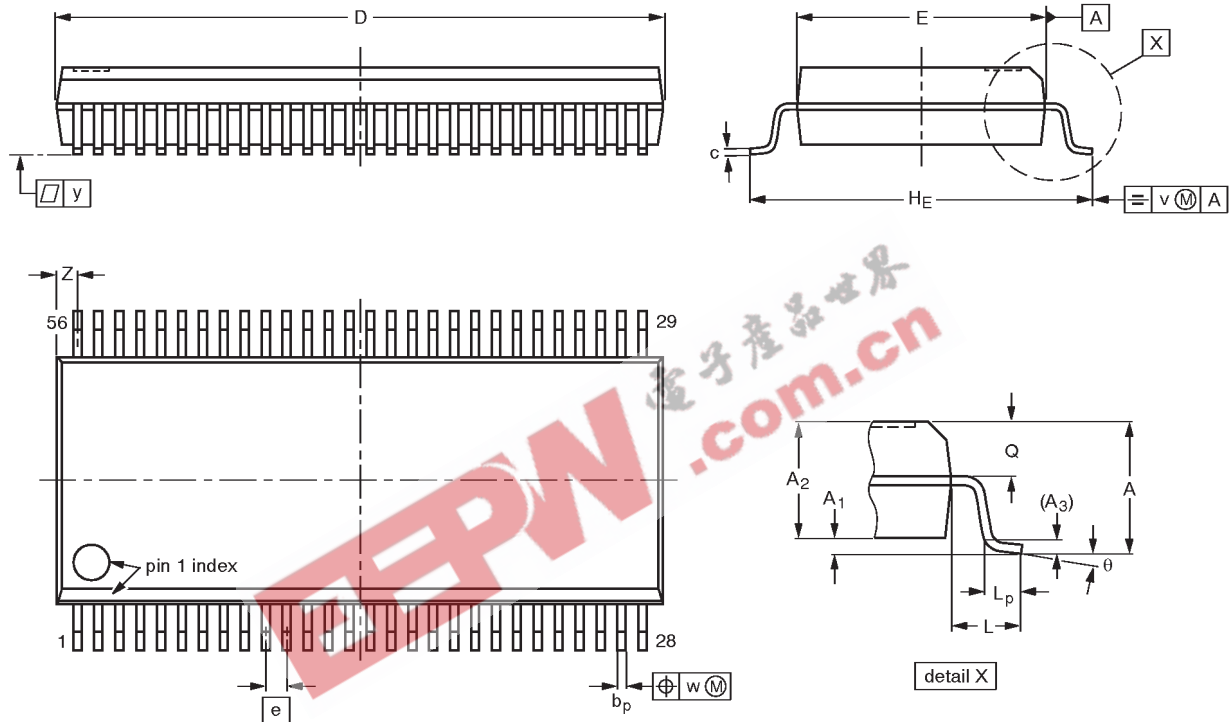

DIMENSIONS (mm are the original dimensions)

UNIT	A max.	A <sub>1</sub>	A <sub>2</sub>	A <sub>3</sub>	b <sub>p</sub>	c	D <sup>(1)</sup>	E <sup>(1)</sup>	e	H <sub>E</sub>	L	L <sub>p</sub>	Q	v	w	y	Z <sup>(1)</sup>	θ
mm	2.8	0.4 0.2	2.35 2.20	0.25	0.3 0.2	0.22 0.13	18.55 18.30	7.6 7.4	0.635	10.4 10.1	1.4	1.0 0.6	1.2 1.0	0.25	0.18	0.1	0.85 0.40	8° 0°

Note

1. Plastic or metal protrusions of 0.25 mm maximum per side are not included.

OUTLINE VERSION	REFERENCES				EUROPEAN PROJECTION	ISSUE DATE
	IEC	JEDEC	EIAJ			
SOT371-1		MO-118AB				93-11-02 95-02-04

# 18-bit bus-interface D-type flip-flop with reset and enable with 30Ω termination resistors (3-State)

## 74ALVT162823

**TSSOP56:** plastic thin shrink small outline package; 56 leads; body width 6.1mm

**SOT364-1**

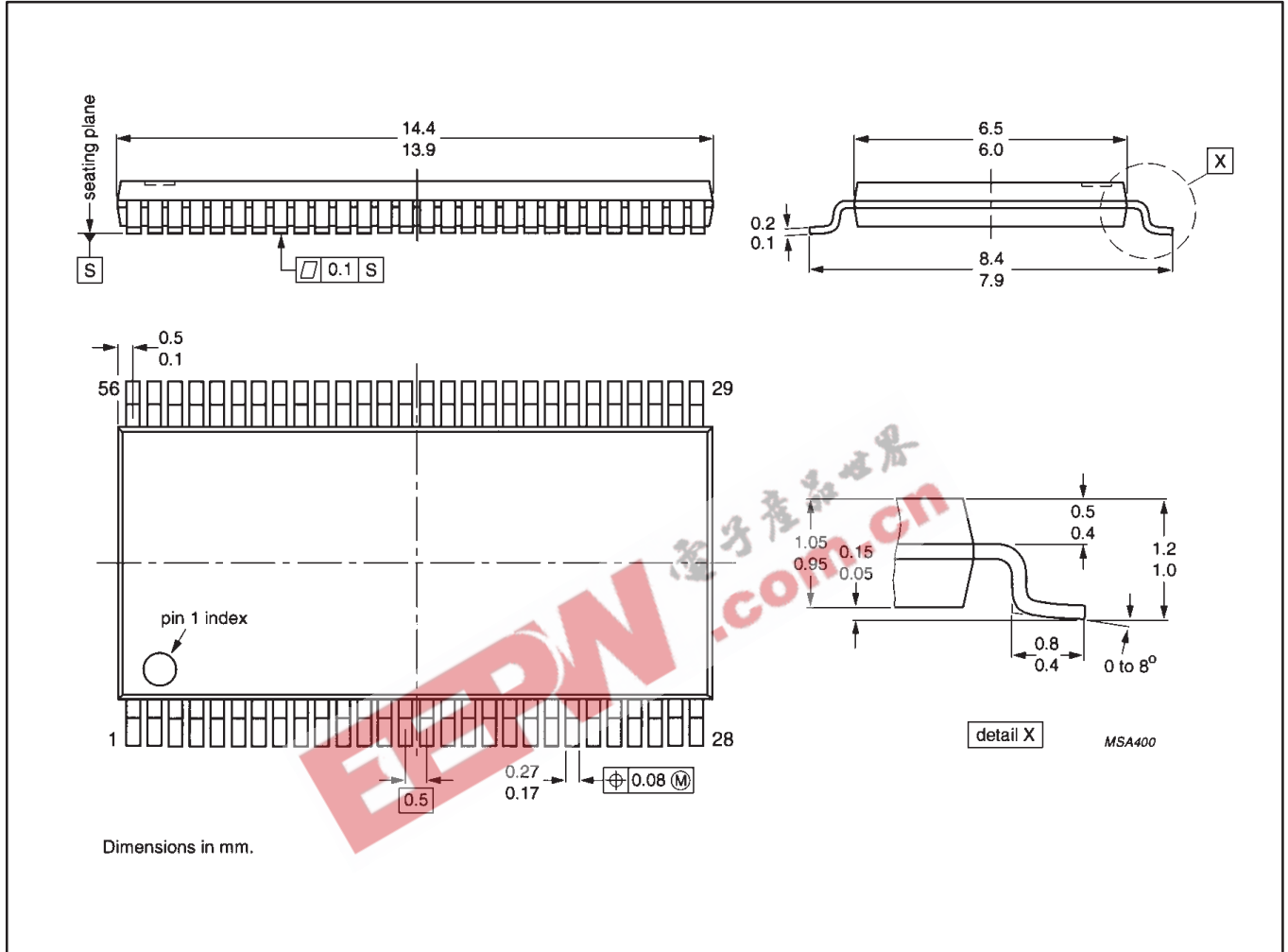

---

18-bit bus-interface D-type flip-flop with reset and enable with 30Ω termination resistors (3-State)

---

74ALVT162823

NOTES

EEPW 电子产品世界  
.com.cn

# 18-bit bus-interface D-type flip-flop with reset and enable with 30Ω termination resistors (3-State)

74ALVT162823

## Data sheet status

Data sheet status	Product status	Definition [1]
Objective specification	Development	This data sheet contains the design target or goal specifications for product development. Specification may change in any manner without notice.
Preliminary specification	Qualification	This data sheet contains preliminary data, and supplementary data will be published at a later date. Philips Semiconductors reserves the right to make changes at any time without notice in order to improve design and supply the best possible product.
Product specification	Production	This data sheet contains final specifications. Philips Semiconductors reserves the right to make changes at any time without notice in order to improve design and supply the best possible product.

[1] Please consult the most recently issued datasheet before initiating or completing a design.

## Definitions

**Short-form specification** — The data in a short-form specification is extracted from a full data sheet with the same type number and title. For detailed information see the relevant data sheet or data handbook.

**Limiting values definition** — Limiting values given are in accordance with the Absolute Maximum Rating System (IEC 134). Stress above one or more of the limiting values may cause permanent damage to the device. These are stress ratings only and operation of the device at these or at any other conditions above those given in the Characteristics sections of the specification is not implied. Exposure to limiting values for extended periods may affect device reliability.

**Application information** — Applications that are described herein for any of these products are for illustrative purposes only. Philips Semiconductors make no representation or warranty that such applications will be suitable for the specified use without further testing or modification.

## Disclaimers

**Life support** — These products are not designed for use in life support appliances, devices or systems where malfunction of these products can reasonably be expected to result in personal injury. Philips Semiconductors customers using or selling these products for use in such applications do so at their own risk and agree to fully indemnify Philips Semiconductors for any damages resulting from such application.

**Right to make changes** — Philips Semiconductors reserves the right to make changes, without notice, in the products, including circuits, standard cells, and/or software, described or contained herein in order to improve design and/or performance. Philips Semiconductors assumes no responsibility or liability for the use of any of these products, conveys no license or title under any patent, copyright, or mask work right to these products, and makes no representations or warranties that these products are free from patent, copyright, or mask work right infringement, unless otherwise specified.

Philips Semiconductors  
811 East Arques Avenue  
P.O. Box 3409  
Sunnyvale, California 94088-3409  
Telephone 800-234-7381

© Copyright Philips Electronics North America Corporation 1998  
All rights reserved. Printed in U.S.A.

print code

Date of release: 05-96

Document order number:

9397-750-03577

*Let's make things better.*