

DATA SHEET

For a complete data sheet, please also download:

- The IC06 74HC/HCT/HCU/HCMOS Logic Family Specifications
- The IC06 74HC/HCT/HCU/HCMOS Logic Package Information
- The IC06 74HC/HCT/HCU/HCMOS Logic Package Outlines

EEPW 电子产品世界
.com.cn

74HC/HCT241

Octal buffer/line driver; 3-state

Product specification
File under Integrated Circuits, IC06

September 1993

Octal buffer/line driver; 3-state

74HC/HCT241

FEATURES

- Output capability: bus driver
- I_{CC} category: MSI

GENERAL DESCRIPTION

The 74HC/HCT241 are high-speed Si-gate CMOS devices and are pin compatible with low power Schottky TTL (LSTTL). They are specified in compliance with JEDEC standard no. 7A.

The 74HC/HCT241 are octal non-inverting buffer/line drivers with 3-state outputs. The 3-state outputs are controlled by the output enable inputs $1\overline{OE}$ and 2OE.

QUICK REFERENCE DATA

GND = 0 V; T_{amb} = 25 °C; t_r = t_f = 6 ns

| SYMBOL | PARAMETER | CONDITIONS | TYPICAL | | UNIT |
|-------------------------------------|---|---|---------|-----|------|
| | | | HC | HCT | |
| t _{PHL} / t _{PLH} | propagation delay 1A _n to 1Y _n ; 2A _n to 2Y _n | C _L = 15 pF; V _{CC} = 5 V | 7 | 11 | ns |
| C _I | input capacitance | | 3.5 | 3.5 | pF |
| C _{PD} | power dissipation capacitance per buffer | notes 1 and 2 | 30 | 30 | pF |

Notes

1. C_{PD} is used to determine the dynamic power dissipation (P_D in μW):

$$P_D = C_{PD} \times V_{CC}^2 \times f_i + \sum (C_L \times V_{CC}^2 \times f_o) \text{ where:}$$

f_i = input frequency in MHz

f_o = output frequency in MHz

∑ (C_L × V_{CC}² × f_o) = sum of outputs

C_L = output load capacitance in pF

V_{CC} = supply voltage in V

2. For HC the condition is V_I = GND to V_{CC}
For HCT the condition is V_I = GND to V_{CC} – 1.5 V

ORDERING INFORMATION

See "74HC/HCT/HCU/HCMOS Logic Package Information".

Octal buffer/line driver; 3-state

74HC/HCT241

PIN DESCRIPTION

| PIN NO. | SYMBOL | NAME AND FUNCTION |
|----------------|------------------------------------|-----------------------------------|
| 1 | $\overline{1OE}$ | output enable input (active LOW) |
| 2, 4, 6, 8 | 1A ₀ to 1A ₃ | data inputs |
| 3, 5, 7, 9 | 2Y ₀ to 2Y ₃ | bus outputs |
| 10 | GND | ground (0 V) |
| 17, 15, 13, 11 | 2A ₀ to 2A ₃ | data inputs |
| 18, 16, 14, 12 | 1Y ₀ to 1Y ₃ | bus outputs |
| 19 | 2OE | output enable input (active HIGH) |
| 20 | V _{CC} | positive supply voltage |

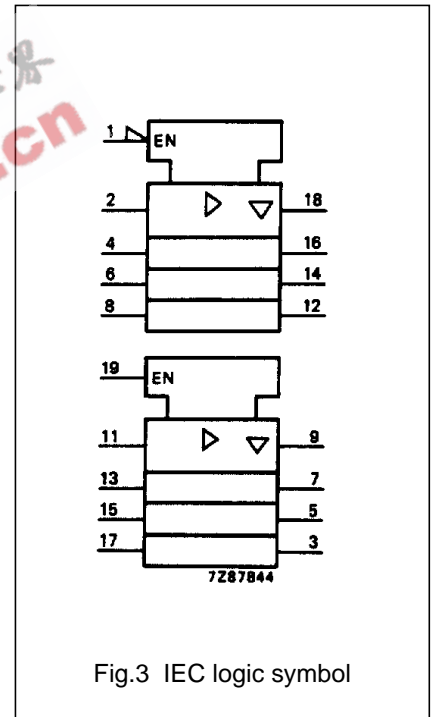
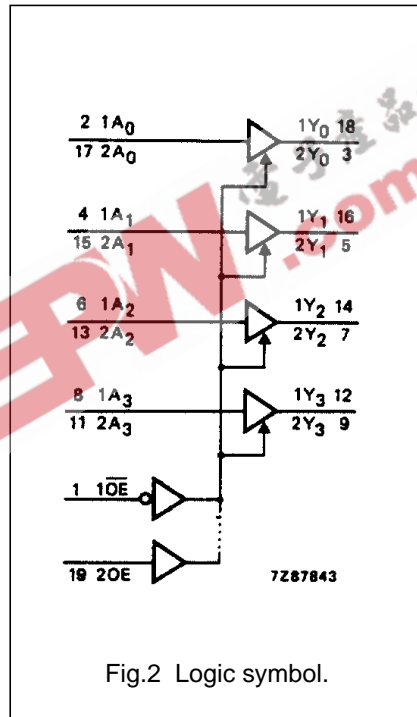
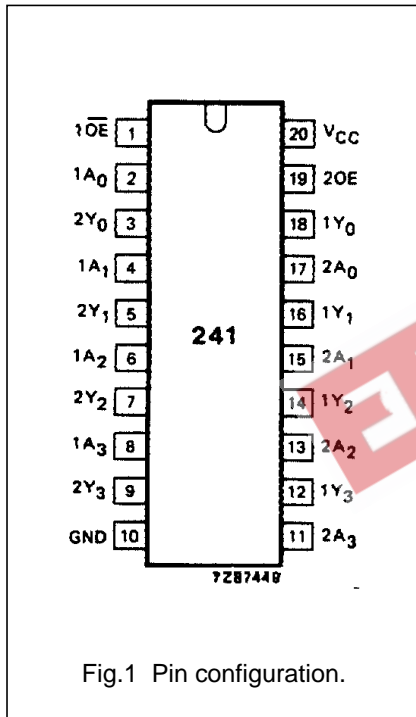

Octal buffer/line driver; 3-state

74HC/HCT241

FUNCTION TABLES

| INPUTS | | OUTPUT |
|------------------|--------|--------|
| $\overline{1OE}$ | $1A_n$ | $1Y_n$ |
| L | L | L |
| L | H | H |
| H | X | Z |

| INPUTS | | OUTPUT |
|--------|--------|--------|
| $2OE$ | $2A_n$ | $2Y_n$ |
| H | L | L |
| H | H | H |
| L | X | Z |

Note

- 1. H = HIGH voltage level
- L = LOW voltage level
- X = don't care
- Z = high impedance OFF-state

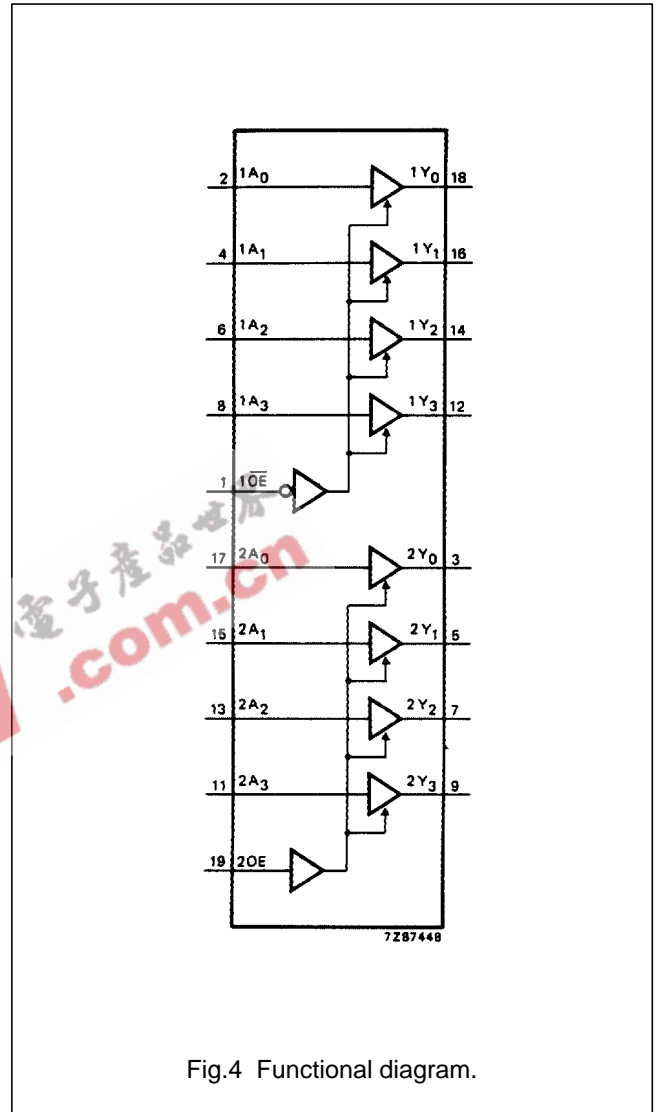

Fig.4 Functional diagram.

Octal buffer/line driver; 3-state

74HC/HCT241

DC CHARACTERISTICS FOR 74HC

For the DC characteristics see *"74HC/HCT/HCU/HCMOS Logic Family Specifications"*.

Output capability: bus driver

I_{CC} category: MSI

AC CHARACTERISTICS FOR 74HC

GND = 0 V; t_r = t_f = 6 ns; C_L = 50 pF

| SYMBOL | PARAMETER | T _{amb} (°C) | | | | | | UNIT | TEST CONDITIONS | | |
|-------------------------------------|---|-----------------------|----------------|-----------------|------------|-----------------|-----------------|------|------------------------|-----------|------|
| | | 74HC | | | | | | | V _{CC} (V) | WAVEFORMS | |
| | | +25 | | | -40 to +85 | | -40 to +125 | | | | |
| | | min. | typ. | max. | min. | max. | min. | | | | max. |
| t _{PHL} / t _{PLH} | propagation delay 1A _n to 1Y _n ; 2A _n to 2Y _n | | 25 9 7 | 100 20 17 | | 125 25 21 | 150 30 26 | ns | 2.0 4.5 6.0 | Fig.5 | |
| t _{PZH} / t _{PZL} | 3-state output enable time 1OE to 1Y _n ; 2OE to 2Y _n | | 30 11 9 | 150 30 26 | | 190 38 33 | 225 45 38 | ns | 2.0 4.5 6.0 | Fig.6 | |
| t _{PHZ} / t _{PLZ} | 3-state output disable time 1OE to 1Y _n ; 2OE to 2Y _n | | 39 14 11 | 150 30 26 | | 190 38 33 | 225 45 38 | ns | 2.0 4.5 6.0 | Fig.6 | |
| t _{THL} / t _{TLH} | output transition time | | 14 5 4 | 60 12 10 | | 75 15 13 | 90 18 15 | ns | 2.0 4.5 6.0 | Fig.5 | |

Octal buffer/line driver; 3-state

74HC/HCT241

DC CHARACTERISTICS FOR 74HCT

For the DC characteristics see *"74HC/HCT/HCU/HCMOS Logic Family Specifications"*.

Output capability: bus driver

I_{CC} category: MSI

Note to HCT types

The value of additional quiescent supply current (ΔI_{CC}) for a unit load of 1 is given in the family specifications. To determine ΔI_{CC} per input, multiply this value by the unit load coefficient shown in the table below.

| INPUT | UNIT LOAD COEFFICIENT |
|-------------------|-----------------------|
| 1A _n | 0.70 |
| 2A _n | 0.70 |
| 1 \overline{OE} | 0.70 |
| 2OE | 1.50 |

AC CHARACTERISTICS FOR 74HCT

GND = 0 V; t_r = t_f = 6 ns; C_L = 50 pF

| SYMBOL | PARAMETER | T _{amb} (°C) | | | | | | UNIT | TEST CONDITIONS | | |
|-------------------------------------|---|-----------------------|------|------|------------|------|-------------|------|------------------------|-----------|-------|
| | | 74HCT | | | | | | | V _{CC} (V) | WAVEFORMS | |
| | | +25 | | | -40 to +85 | | -40 to +125 | | | | |
| | | min. | typ. | max. | min. | max. | min. | | | | max. |
| t _{PHL} / t _{PLH} | propagation delay 1A _n to 1Y _n ; 2A _n to 2Y _n | | 13 | 22 | | 28 | | 33 | ns | 4.5 | Fig.5 |
| t _{PZH} / t _{PZL} | 3-state output enable time 1 \overline{OE} to 1Y _n ; 2OE to 2Y _n | | 15 | 30 | | 38 | | 45 | ns | 4.5 | Fig.6 |
| t _{PHZ} / t _{PLZ} | 3-state output disable time 1 \overline{OE} to 1Y _n ; 2OE to 2Y _n | | 18 | 30 | | 38 | | 45 | ns | 4.5 | Fig.6 |
| t _{THL} / t _{TLH} | output transition time | | 5 | 12 | | 15 | | 18 | ns | 4.5 | Fig.5 |

Octal buffer/line driver; 3-state

74HC/HCT241

AC WAVEFORMS

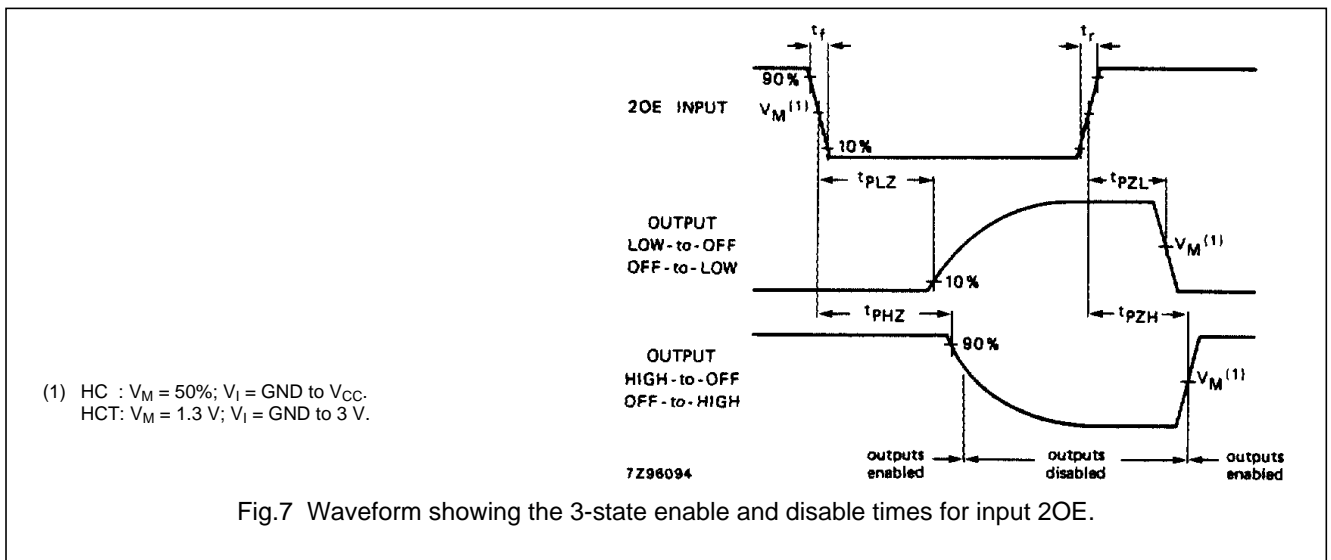
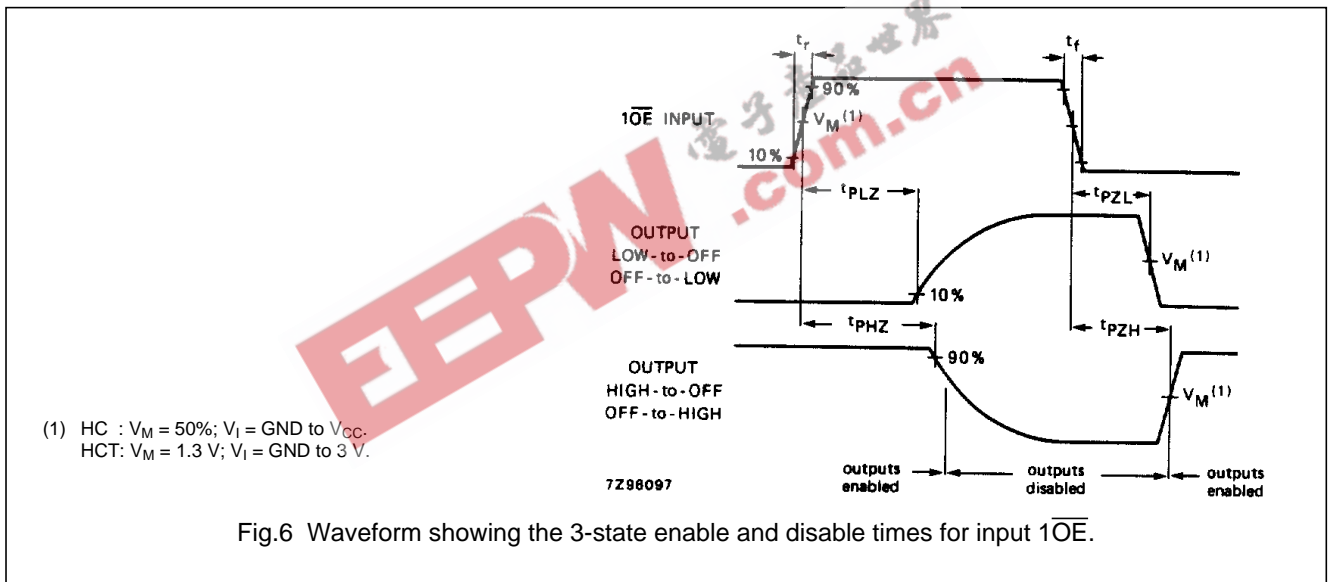
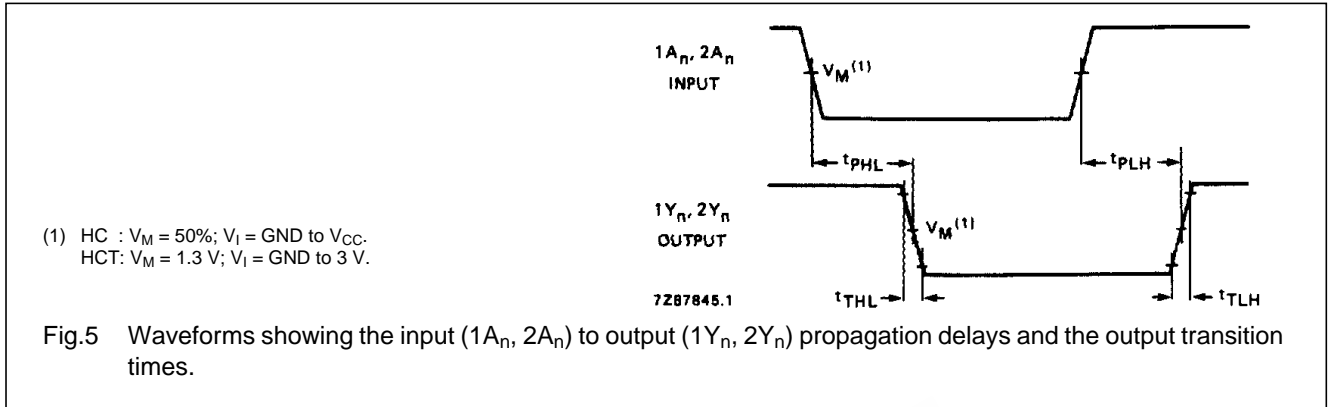

Octal buffer/line driver; 3-state

74HC/HCT241

PACKAGE OUTLINES

See *"74HC/HCT/HCU/HCMOS Logic Package Outlines"*.

