

54AC16652, 74AC16652 16-BIT BUS TRANSCEIVERS AND REGISTERS WITH 3-STATE OUTPUTS

SCAS242A – MARCH 1990 – REVISED APRIL 1996

- Members of the Texas Instruments *Widebus*™ Family
- Independent Registers and Enables for A and B Buses
- Multiplexed Real-Time and Stored Data
- Flow-Through Architecture Optimizes PCB Layout
- Distributed V_{CC} and GND Pin Configurations Minimize High-Speed Switching Noise
- *EPIC*™ (Enhanced-Performance Implanted CMOS) 1- μ m Process
- 500-mA Typical Latch-Up Immunity at 125°C
- Package Options Include Plastic 300-mil Shrink Small-Outline (DL) Packages Using 25-mil Center-to-Center Pin Spacings and 380-mil Fine-Pitch Ceramic Flat (WD) Packages Using 25-mil Center-to-Center Pin Spacings

54AC16652 . . . WD PACKAGE
74AC16652 . . . DL PACKAGE
(TOP VIEW)

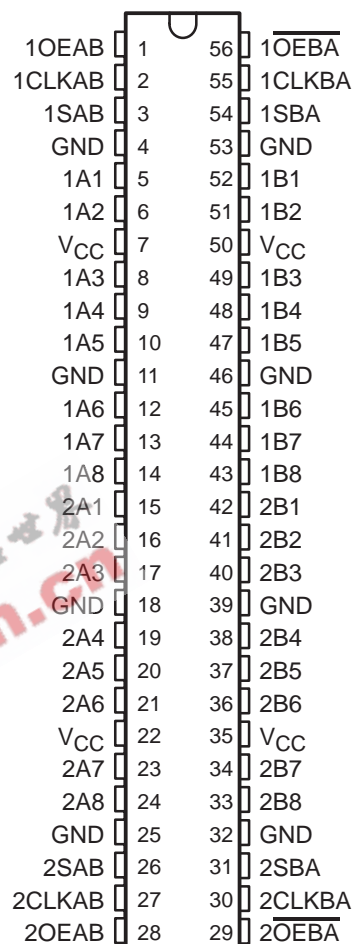

description

The 'AC16652 are 16-bit bus transceivers that consist of D-type flip-flops and control circuitry arranged for multiplexed transmission of data directly from the data bus or from the internal storage registers. They can be used as two 8-bit transceivers or one 16-bit transceiver.

Complementary output-enable (OEAB and OEBA) inputs are provided to control the transceiver functions. Select-control (SAB and SBA) inputs are provided to select whether real-time or stored data is transferred. A low input level selects real-time data, and a high input level selects stored data. The circuitry used for select control eliminates the typical decoding glitch that occurs in a multiplexer during the transition between stored and real-time data. Figure 1 illustrates the four fundamental bus-management functions that can be performed with the 'AC16652.



Please be aware that an important notice concerning availability, standard warranty, and use in critical applications of Texas Instruments semiconductor products and disclaimers thereto appears at the end of this data sheet.

EPIC and Widebus are trademarks of Texas Instruments Incorporated.

UNLESS OTHERWISE NOTED this document contains PRODUCTION DATA information current as of publication date. Products conform to specifications per the terms of Texas Instruments standard warranty. Production processing does not necessarily include testing of all parameters.

 **TEXAS
INSTRUMENTS**

Copyright © 1996, Texas Instruments Incorporated

54AC16652, 74AC16652 16-BIT BUS TRANSCEIVERS AND REGISTERS WITH 3-STATE OUTPUTS

SCAS242A – MARCH 1990 – REVISED APRIL 1996

description (continued)

Data on the A or B bus, or both, can be stored in the internal D flip-flops by low-to-high transitions at the appropriate clock (CLKAB or CLKBA) inputs regardless of the levels on the select-control or output-enable inputs. When SAB and SBA are in the real-time transfer mode, it is also possible to store data without using the internal D-type flip-flops by simultaneously enabling OEAB and \overline{OEBA} . In this configuration, each output reinforces its input. Thus, when all other data sources to the two sets of bus lines are at high impedance, each set of bus lines remains at its last state.

The 74AC16652 is packaged in TI's shrink small-outline package (DL), which provides twice the I/O pin count and functionality of standard small-outline packages in the same printed-circuit-board area.

The 54AC16652 is characterized for operation over the full military temperature range of -55°C to 125°C . The 74AC16652 is characterized for operation from -40°C to 85°C .

FUNCTION TABLE

INPUTS						DATA I/O†		OPERATION OR FUNCTION
OEAB	\overline{OEBA}	CLKAB	CLKBA	SAB	SBA	A1–A8	B1–B8	
L	H	L	L	X	X	Input	Input	Isolation
L	H	↑	↑	X	X	Input	Input	Store A and B data
X	H	↑	L	X	X	Input	Unspecified‡	Store A, hold B
H	H	↑	↑	X‡	X	Input	Output	Store A in both registers
L	X	L	↑	X	X	Unspecified‡	Input	Hold A, store B
L	L	↑	↑	X	X‡	Output	Input	Store B in both registers
L	L	X	X	X	L	Output	Input	Real-time B data to A bus
L	L	X	L	X	H	Output	Input	Stored B data to A bus
H	H	X	X	L	X	Input	Output	Real-time A data to B bus
H	H	L	X	H	X	Input	Output	Stored A data to B bus
H	L	L	L	H	H	Output	Output	Stored A data to B bus and stored B data to A bus

† The data-output functions may be enabled or disabled by a variety of level combinations at OEAB or \overline{OEBA} . Data-input functions are always enabled; i.e., data at the bus terminals is stored on every low-to-high transition on the clock inputs.

‡ Select control = L; clocks can occur simultaneously.

Select control = H; clocks must be staggered in order to load both registers.

54AC16652, 74AC16652
 16-BIT BUS TRANSCEIVERS AND REGISTERS
 WITH 3-STATE OUTPUTS

SCAS242A – MARCH 1990 – REVISED APRIL 1996

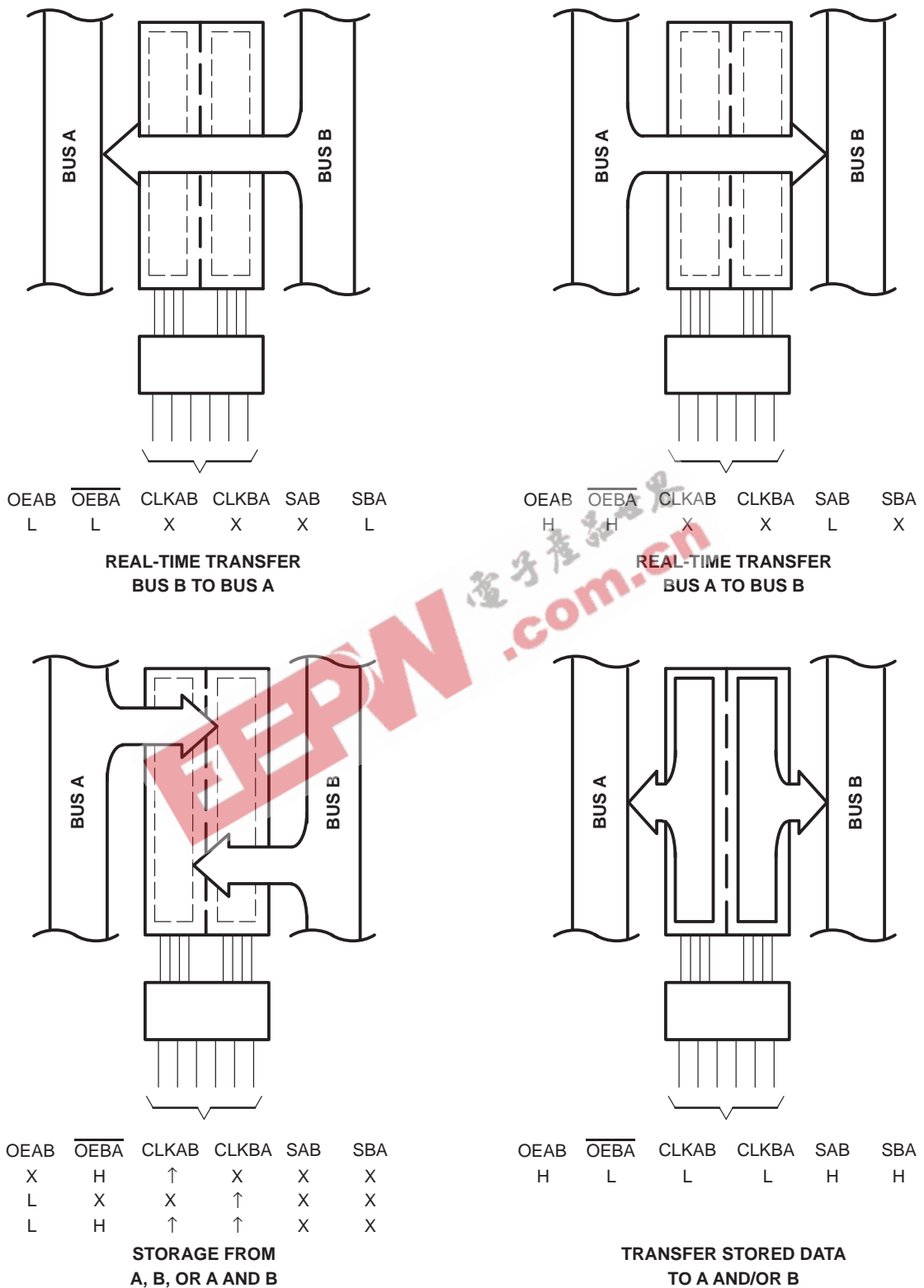
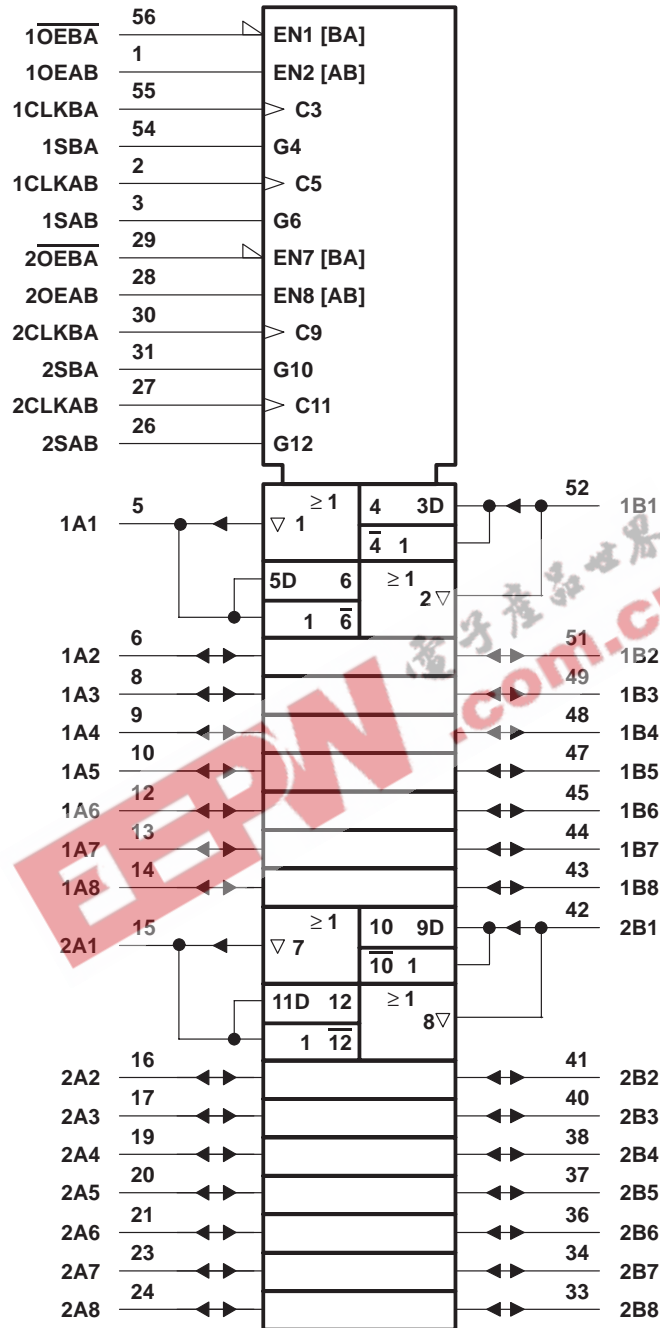

Figure 1. Bus-Management Functions

54AC16652, 74AC16652 16-BIT BUS TRANSCEIVERS AND REGISTERS WITH 3-STATE OUTPUTS

SCAS242A – MARCH 1990 – REVISED APRIL 1996

logic symbol†



† This symbol is in accordance with ANSI/IEEE Std 91-1984 and IEC Publication 617-12.

54AC16652, 74AC16652 16-BIT BUS TRANSCEIVERS AND REGISTERS WITH 3-STATE OUTPUTS

SCAS242A – MARCH 1990 – REVISED APRIL 1996

logic diagram (positive logic)

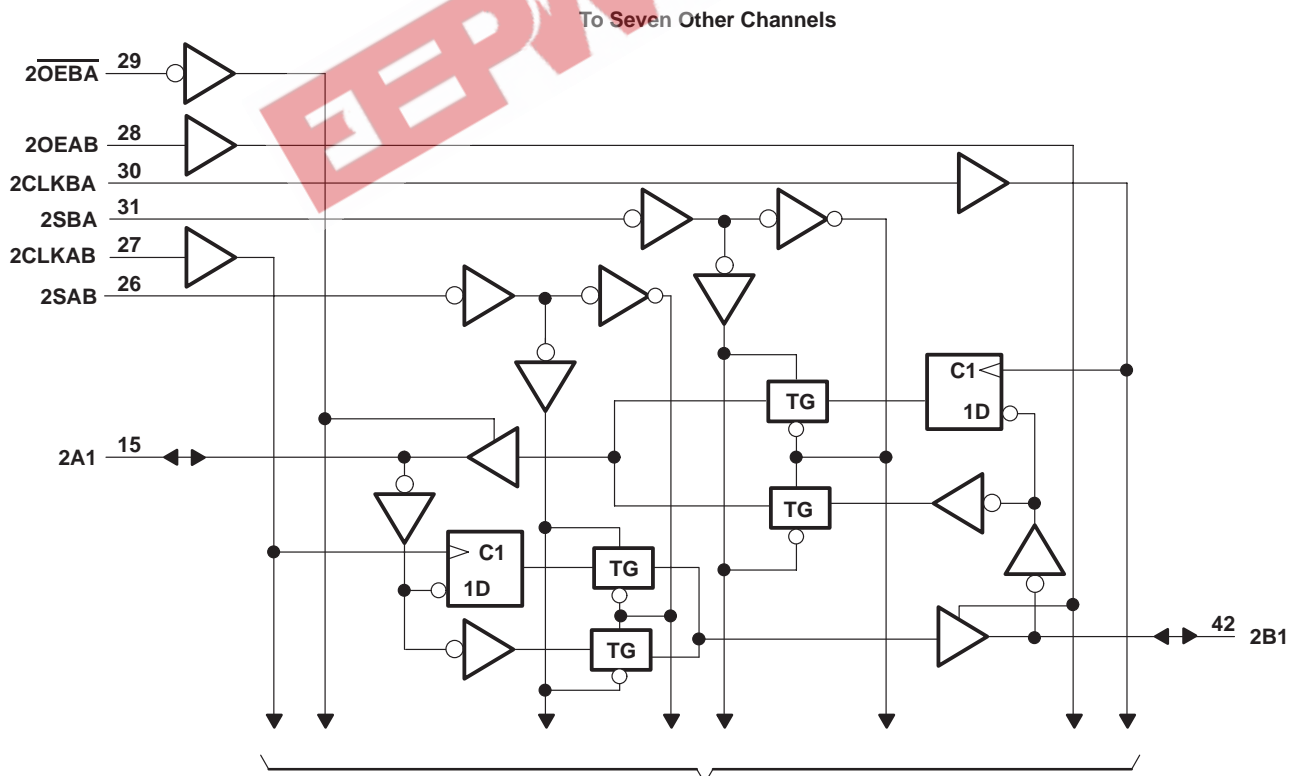
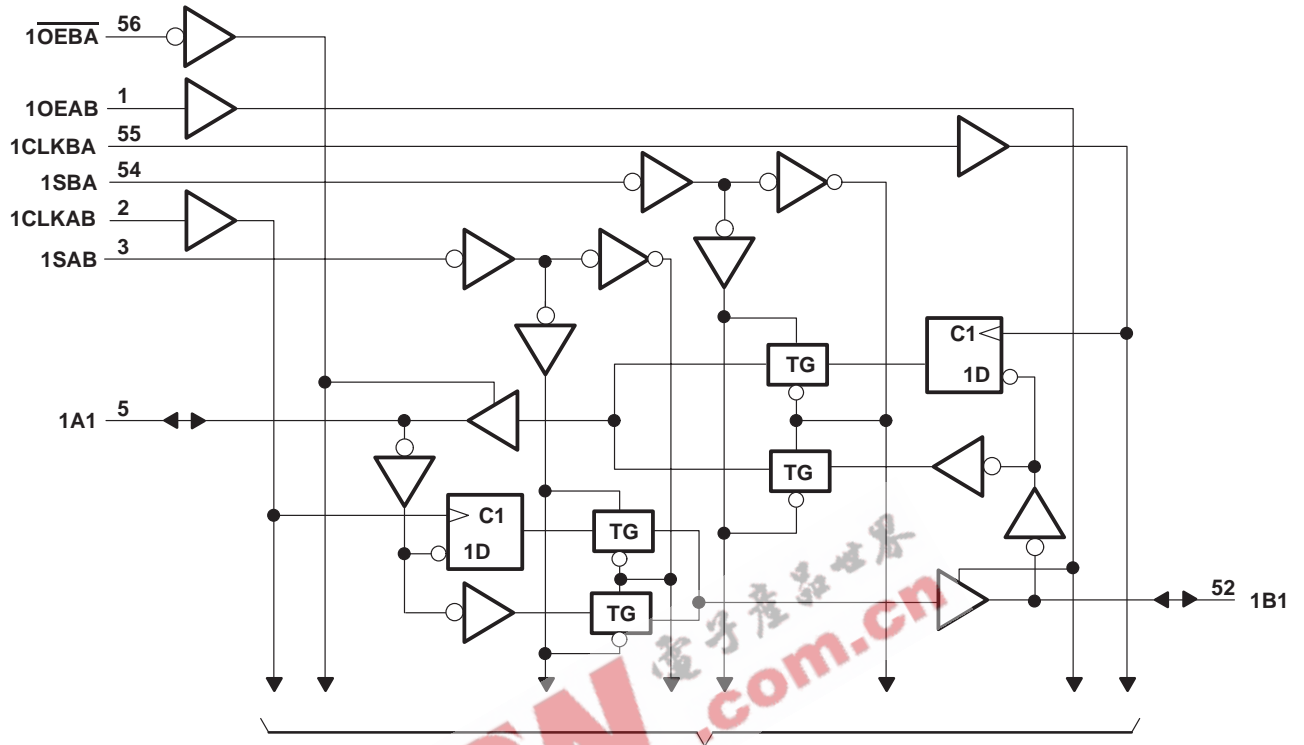

54AC16652, 74AC16652 16-BIT BUS TRANSCEIVERS AND REGISTERS WITH 3-STATE OUTPUTS

SCAS242A – MARCH 1990 – REVISED APRIL 1996

absolute maximum ratings over operating free-air temperature range (unless otherwise noted)†

Supply voltage range, V_{CC}	–0.5 V to 7 V
Input voltage range, V_I (see Note 1)	–0.5 V to $V_{CC} + 0.5$ V
Output voltage range, V_O (see Note 1)	–0.5 V to $V_{CC} + 0.5$ V
Input clamp current, I_{IK} ($V_I < 0$ or $V_I > V_{CC}$)	±20 mA
Output clamp current, I_{OK} ($V_O < 0$ or $V_O > V_{CC}$)	±50 mA
Continuous output current, I_O ($V_O = 0$ to V_{CC})	±50 mA
Continuous current through V_{CC} or GND	±400 mA
Maximum package power dissipation at $T_A = 55^\circ\text{C}$ (in still air) (see Note 2): DL package	1.4 W
Storage temperature range, T_{stg}	–65°C to 150°C

† Stresses beyond those listed under “absolute maximum ratings” may cause permanent damage to the device. These are stress ratings only, and functional operation of the device at these or any other conditions beyond those indicated under “recommended operating conditions” is not implied. Exposure to absolute-maximum-rated conditions for extended periods may affect device reliability.

- NOTES: 1. The input and output voltage ratings may be exceeded if the input and output current ratings are observed.
2. The maximum package power dissipation is calculated using a junction temperature of 150°C and a board trace length of 750 mils.

recommended operating conditions (see Note 3)

		54AC16652			74AC16652			UNIT
		MIN	NOM	MAX	MIN	NOM	MAX	
V_{CC}	Supply voltage (see Note 4)	3	5	5.5	3	5	5.5	V
V_{IH}	High-level input voltage	$V_{CC} = 3$ V		2.1	2.1		V	
		$V_{CC} = 4.5$ V		3.15	3.15			
		$V_{CC} = 5.5$ V		3.85	3.85			
V_{IL}	Low-level input voltage	$V_{CC} = 3$ V			0.9		V	
		$V_{CC} = 4.5$ V			1.35			
		$V_{CC} = 5.5$ V			1.65			
V_I	Input voltage	0		V_{CC}	0	V_{CC}	V	
V_O	Output voltage	0		V_{CC}	0	V_{CC}	V	
I_{OH}	High-level output current	$V_{CC} = 3$ V			–4		mA	
		$V_{CC} = 4.5$ V			–24			
		$V_{CC} = 5.5$ V			–24			
I_{OL}	Low-level output current	$V_{CC} = 3$ V			12		mA	
		$V_{CC} = 4.5$ V			24			
		$V_{CC} = 5.5$ V			24			
$\Delta t/\Delta v$	Input transition rise or fall rate	0		10	0	10	ns/V	
T_A	Operating free-air temperature	–55		125	–40	85	°C	

- NOTES: 3. Unused inputs must be held high or low to prevent them from floating.
4. All V_{CC} and GND pins must be connected to the proper voltage power supply.

54AC16652, 74AC16652 16-BIT BUS TRANSCEIVERS AND REGISTERS WITH 3-STATE OUTPUTS

SCAS242A – MARCH 1990 – REVISED APRIL 1996

electrical characteristics over recommended operating free-air temperature range (unless otherwise noted)

PARAMETER	TEST CONDITIONS	V _{CC}	T _A = 25°C			54AC16652		74AC16652		UNIT
			MIN	TYP	MAX	MIN	MAX	MIN	MAX	
V _{OH}	I _{OH} = -50 μA	3 V	2.9			2.9		2.9	V	
		4.5 V	4.4			4.4		4.4		
		5.5 V	5.4			5.4		5.4		
	I _{OH} = -4 mA	3 V	2.58			2.4		2.48		
		4.5 V	3.94			3.7		3.8		
	I _{OH} = -24 mA	5.5 V	4.94			4.7		4.8		
		5.5 V				3.85				
V _{OL}	I _{OL} = 50 μA	3 V			0.1		0.1	0.1	V	
		4.5 V			0.1		0.1	0.1		
		5.5 V			0.1		0.1	0.1		
	I _{OL} = 12 mA	3 V			0.36		0.5	0.44		
		4.5 V			0.36		0.5	0.44		
	I _{OL} = 24 mA	5.5 V			0.36		0.5	0.44		
		5.5 V					1.65			
	I _{OL} = 50 mA [†]	5.5 V					1.65			
	I _{OL} = 75 mA [†]	5.5 V						1.65		
	I _I	Control inputs	V _I = V _{CC} or GND	5.5 V			±0.1			±1
I _{OZ}	A or B ports [‡]	V _O = V _{CC} or GND	5.5 V			±0.5		±10	±5	μA
I _{CC}		V _I = V _{CC} or GND, I _O = 0	5.5 V			8		160	80	μA
C _i	Control inputs	V _I = V _{CC} or GND	5 V			4				pF
C _{io}	A or B ports	V _O = V _{CC} or GND	5 V			12				pF

[†] Not more than one output should be tested at a time, and the duration of the test should not exceed 10 ms.

[‡] For I/O ports, the parameter I_{OZ} includes the input leakage current.

timing requirements over recommended operating free-air temperature range, V_{CC} = 3.3 V ± 0.3 V (unless otherwise noted) (see Figure 2)

		T _A = 25°C		54AC16652		74AC16652		UNIT
		MIN	MAX	MIN	MAX	MIN	MAX	
f _{clock}	Clock frequency	0	55	0	55	0	55	MHz
t _w	Pulse duration, CLKAB or CLKBA high or low	9		9		9		ns
t _{su}	Setup time, A before CLKAB [↑] or B before CLKBA [↑]	7		7		7		ns
t _h	Hold time, A after CLKAB [↑] or B after CLKBA [↑]	0		0		0		ns

timing requirements over recommended operating free-air temperature range, V_{CC} = 5 V ± 0.5 V (unless otherwise noted) (see Figure 2)

		T _A = 25°C		54AC16652		74AC16652		UNIT
		MIN	MAX	MIN	MAX	MIN	MAX	
f _{clock}	Clock frequency	0	95	0	95	0	95	MHz
t _w	Pulse duration, CLKAB or CLKBA high or low	5		5		5		ns
t _{su}	Setup time, A before CLKAB [↑] or B before CLKBA [↑]	4.5		4.5		4.5		ns
t _h	Hold time, A after CLKAB [↑] or B after CLKBA [↑]	0		0		0		ns

PRODUCT PREVIEW information concerns products in the formative or design phase of development. Characteristic data and other specifications are design goals. Texas Instruments reserves the right to change or discontinue these products without notice.



POST OFFICE BOX 655303 • DALLAS, TEXAS 75265

54AC16652, 74AC16652

16-BIT BUS TRANSCEIVERS AND REGISTERS

WITH 3-STATE OUTPUTS

SCAS242A – MARCH 1990 – REVISED APRIL 1996

switching characteristics over recommended operating free-air temperature range,
 $V_{CC} = 3.3\text{ V} \pm 0.3\text{ V}$ (unless otherwise noted) (see Figure 2)

PARAMETER	FROM (INPUT)	TO (OUTPUT)	$T_A = 25^\circ\text{C}$			54AC16652		74AC16652		UNIT
			MIN	TYP	MAX	MIN	MAX	MIN	MAX	
f_{\max}			55			55		55		MHz
t_{PLH}	A or B	B or A	3.6	10.4	13.7	3.6	17.1	3.6	15.6	ns
t_{PHL}			4.1	10.9	14.3	4.1	16.3	4.1	15.4	
t_{PLH}	CLKBA or CLKAB	A or B	5.1	13.6	17.3	5.1	21.2	5.1	19.5	ns
t_{PHL}			5.4	13.5	17.2	5.4	19.9	5.4	18.8	
t_{PLH}	SBA or SAB (with A or B high)	A or B	5.8	15.0	18.7	5.8	23.3	5.8	21.4	ns
t_{PHL}			5.4	13.1	16.7	5.4	19.1	5.4	18.1	
t_{PLH}	SBA or SAB (with A or B low)	A or B	4.2	11.8	15.2	4.2	18.9	4.2	17.4	ns
t_{PHL}			5.9	14.4	18.3	5.9	21.7	5.9	20.3	
t_{PZH}	$\overline{\text{OEBA}}$	A	4.2	11.8	15.1	4.2	18.8	4.2	17.2	ns
t_{PZL}			6	16.2	20.6	6	25.3	6	23.5	
t_{PHZ}	$\overline{\text{OEBA}}$	A	4.6	8.1	10	4.6	10.9	4.6	10.6	ns
t_{PLZ}			4.4	7.6	9.6	4.4	10.6	4.4	10.3	
t_{PZH}	OEAB	B	4.1	11.5	14.6	4.1	18.1	4.1	16.6	ns
t_{PZL}			6	16.0	20	6	24.6	6	22.7	
t_{PHZ}	OEAB	B	4.3	7.2	9	4.3	9.7	4.3	9.5	ns
t_{PLZ}			3.9	6.7	8.6	3.9	9.2	3.9	9.1	

switching characteristics over recommended operating free-air temperature range,
 $V_{CC} = 5\text{ V} \pm 0.5\text{ V}$ (unless otherwise noted) (see Figure 2)

PARAMETER	FROM (INPUT)	TO (OUTPUT)	$T_A = 25^\circ\text{C}$			54AC16652		74AC16652		UNIT
			MIN	TYP	MAX	MIN	MAX	MIN	MAX	
f_{\max}			95			95		95		MHz
t_{PLH}	A or B	B or A	2.7	6.1	8.8	2.7	10.7	2.7	9.9	ns
t_{PHL}			3	6.3	9.2	3	10.8	3	10.2	
t_{PLH}	CLKBA or CLKAB	A or B	3.9	7.8	10.9	3.9	13.3	3.9	12.2	ns
t_{PHL}			4.2	7.8	11.1	4.2	13.2	4.2	12.3	
t_{PLH}	SBA or SAB (with A or B high)	A or B	4.5	8.8	12.1	4.5	15	4.5	13.8	ns
t_{PHL}			4.1	7.7	11	4.1	12.9	4.1	12.1	
t_{PLH}	SBA or SAB (with A or B low)	A or B	3.1	6.7	9.7	3.1	11.9	3.1	11	ns
t_{PHL}			4.6	8.8	12.2	4.6	14.9	4.6	13.8	
t_{PZH}	$\overline{\text{OEBA}}$	A	3.1	6.7	9.5	3.1	11.6	3.1	10.7	ns
t_{PZL}			4.5	8.3	11.8	4.5	14.4	4.5	13.2	
t_{PHZ}	$\overline{\text{OEBA}}$	A	4.6	6.5	8.3	4.6	9	4.6	8.8	ns
t_{PLZ}			4.1	6.1	8.1	4.1	9.1	4.1	8.7	
t_{PZH}	OEAB	B	3.1	6.6	9.3	3.1	11.3	3.1	10.5	ns
t_{PZL}			4.6	8.2	11.6	4.6	14.1	4.6	13	
t_{PHZ}	OEAB	B	4.2	5.9	7.7	4.2	8.3	4.2	8	ns
t_{PLZ}			3.7	5.5	7.4	3.7	8.3	3.7	7.8	

PRODUCT PREVIEW information concerns products in the formative or design phase of development. Characteristic data and other specifications are design goals. Texas Instruments reserves the right to change or discontinue these products without notice.



POST OFFICE BOX 655303 • DALLAS, TEXAS 75265

54AC16652, 74AC16652 16-BIT BUS TRANSCEIVERS AND REGISTERS WITH 3-STATE OUTPUTS

SCAS242A – MARCH 1990 – REVISED APRIL 1996

operating characteristics, $V_{CC} = 5\text{ V}$, $T_A = 25^\circ\text{C}$

PARAMETER		TEST CONDITIONS	TYP	UNIT
C _{pd}	Power dissipation capacitance per transceiver	Outputs enabled	57	pF
		Outputs disabled	13	

PARAMETER MEASUREMENT INFORMATION

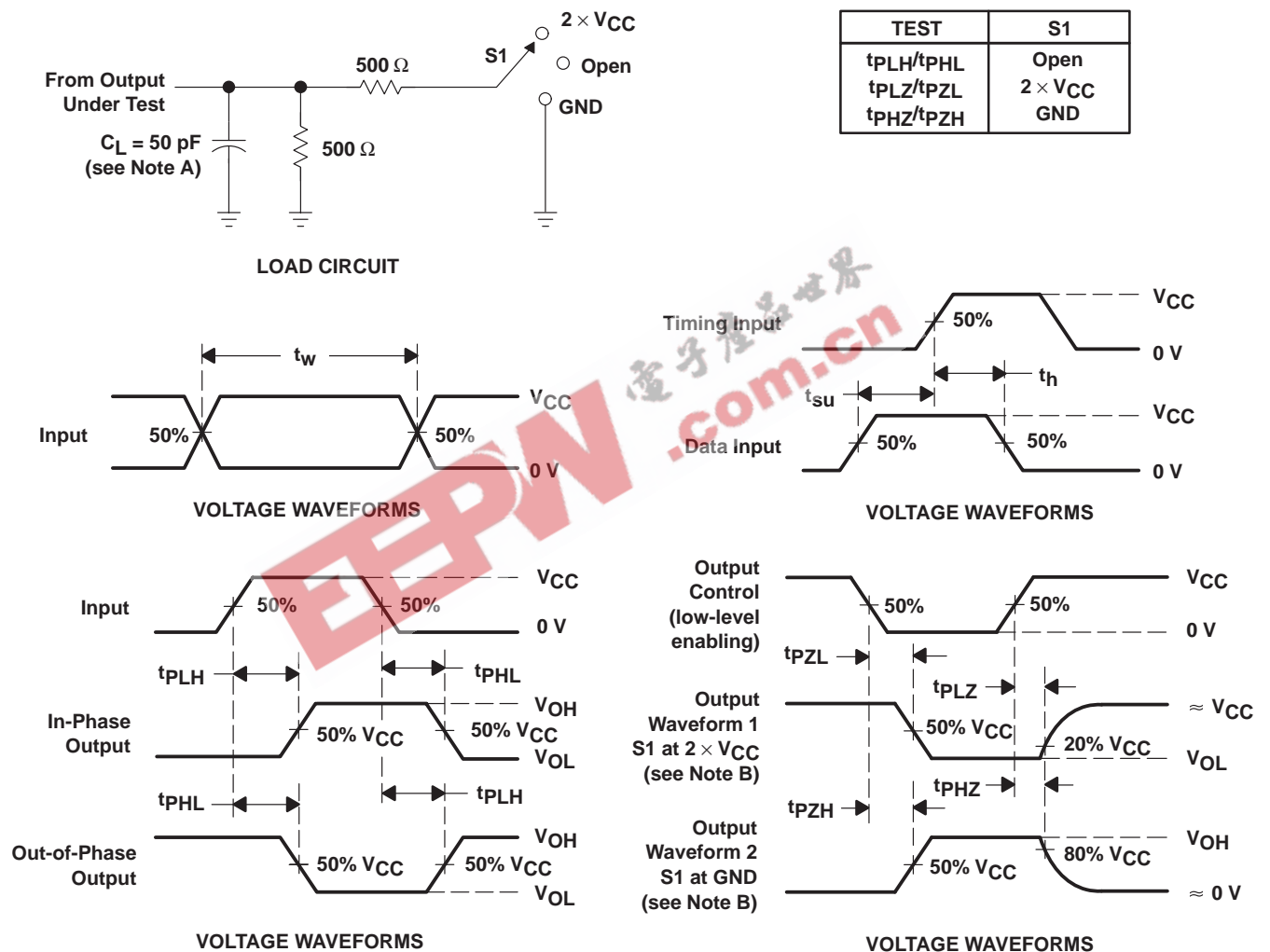

- NOTES: A. C_L includes probe and jig capacitance.
 B. Waveform 1 is for an output with internal conditions such that the output is low except when disabled by the output control. Waveform 2 is for an output with internal conditions such that the output is high except when disabled by the output control.
 C. All input pulses are supplied by generators having the following characteristics: PRR ≤ 1 MHz, Z_O = 50 Ω, t_r = 3 ns, t_f = 3 ns.
 D. The outputs are measured one at a time with one input transition per measurement.

Figure 2. Load Circuit and Voltage Waveforms

IMPORTANT NOTICE

Texas Instruments and its subsidiaries (TI) reserve the right to make changes to their products or to discontinue any product or service without notice, and advise customers to obtain the latest version of relevant information to verify, before placing orders, that information being relied on is current and complete. All products are sold subject to the terms and conditions of sale supplied at the time of order acknowledgement, including those pertaining to warranty, patent infringement, and limitation of liability.

TI warrants performance of its semiconductor products to the specifications applicable at the time of sale in accordance with TI's standard warranty. Testing and other quality control techniques are utilized to the extent TI deems necessary to support this warranty. Specific testing of all parameters of each device is not necessarily performed, except those mandated by government requirements.

CERTAIN APPLICATIONS USING SEMICONDUCTOR PRODUCTS MAY INVOLVE POTENTIAL RISKS OF DEATH, PERSONAL INJURY, OR SEVERE PROPERTY OR ENVIRONMENTAL DAMAGE ("CRITICAL APPLICATIONS"). TI SEMICONDUCTOR PRODUCTS ARE NOT DESIGNED, AUTHORIZED, OR WARRANTED TO BE SUITABLE FOR USE IN LIFE-SUPPORT DEVICES OR SYSTEMS OR OTHER CRITICAL APPLICATIONS. INCLUSION OF TI PRODUCTS IN SUCH APPLICATIONS IS UNDERSTOOD TO BE FULLY AT THE CUSTOMER'S RISK.

In order to minimize risks associated with the customer's applications, adequate design and operating safeguards must be provided by the customer to minimize inherent or procedural hazards.

TI assumes no liability for applications assistance or customer product design. TI does not warrant or represent that any license, either express or implied, is granted under any patent right, copyright, mask work right, or other intellectual property right of TI covering or relating to any combination, machine, or process in which such semiconductor products or services might be or are used. TI's publication of information regarding any third party's products or services does not constitute TI's approval, warranty or endorsement thereof.