

DATA SHEET

EEPW 电子产品世界
.com.cn

74ABT16245B
74ABTH16245B
16-bit bus transceiver (3-state)

Product specification
Supersedes data of 1996 Nov 20
IC23 Data Handbook

1998 Feb 25

16-bit bus transceiver (3-State)

74ABT16245B 74ABTH16245B

FEATURES

- 16-bit bidirectional bus interface
- Power-up 3-State
- Multiple V_{CC} and GND pins minimize switching noise
- 3-State buffers
- Output capability: +64 mA/-32mA
- Latch-up protection exceeds 500mA per JEDEC Std 17
- Live insertion/extraction permitted
- ESD protection exceeds 2000 V per MIL STD 883 Method 3015 and 200V per Machine Model
- 74ABTH16245B incorporates bus hold data inputs which eliminate the need for external pull-up resistors to hold unused inputs
- Bus-hold data inputs eliminate the need for external pull-up resistors to hold unused inputs

DESCRIPTION

The 74ABT16245B high-performance BiCMOS device combines low static and dynamic power dissipation with high speed and high output drive.

The 74ABT16245B device is a dual octal transceiver featuring non-inverting 3-State bus compatible outputs in both send and receive directions. The control function implementation minimizes external timing requirements. The device features two Output Enable (1OE, 2OE) inputs for easy cascading and two Direction (1DIR, 2DIR) inputs for direction control.

Two options are available, 74ABT16245B which does not have the bus hold feature and the 74ABTH16245B which incorporates the bus hold feature.

QUICK REFERENCE DATA

SYMBOL	PARAMETER	CONDITIONS $T_{amb} = 25^{\circ}\text{C}; \text{GND} = 0\text{V}$	TYPICAL	UNIT
t_{PLH} t_{PHL}	Propagation delay nAx to nBx or nBx to nAx	$C_L = 50\text{pF}; V_{CC} = 5\text{V}$	2.0 2.3	ns
C_{IN}	Input capacitance	$V_I = 0\text{V}$ or V_{CC}	4	pF
$C_{I/O}$	I/O pin capacitance	$V_O = 0\text{V}$ or V_{CC} ; 3-State	7	pF
I_{CCZ}	Quiescent supply current	Outputs disabled; $V_{CC} = 5.5\text{V}$	500	μA
I_{CCL}		Output Low; $V_{CC} = 5.5\text{V}$	10	mA

ORDERING INFORMATION

PACKAGES	TEMPERATURE RANGE	OUTSIDE NORTH AMERICA	NORTH AMERICA	DWG NUMBER
48-Pin Plastic SSOP Type III	-40°C to +85°C	74ABT16245B DL	BT16245B DL	SOT370-1
48-Pin Plastic TSSOP Type II	-40°C to +85°C	74ABT16245B DGG	BT16245B DGG	SOT362-1
48-Pin Plastic SSOP Type III	-40°C to +85°C	74ABTH16245B DL	BH16245B DL	SOT370-1
48-Pin Plastic TSSOP Type II	-40°C to +85°C	74ABTH16245B DGG	BH16245B DGG	SOT362-1

16-bit bus transceiver (3-State)

74ABT16245B
74ABTH16245B

PIN CONFIGURATION

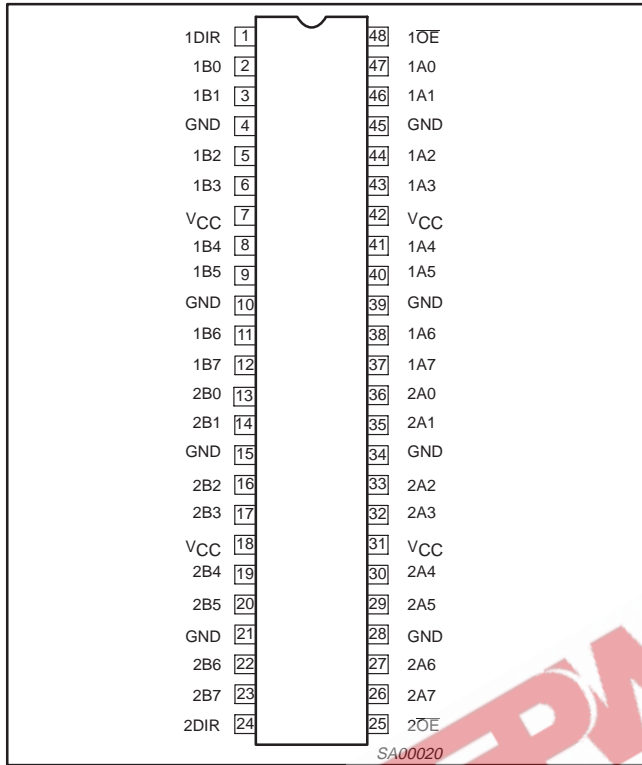

PIN DESCRIPTION

SYMBOL	PIN NUMBER	NAME AND FUNCTION
1DIR, 2DIR	1, 24	Direction control inputs (Active-High)
1A0 – 1A7, 2A0 – 2A7	47, 46, 44, 43, 41, 40, 38, 37, 36, 35, 33, 32, 30, 29, 27, 26	Data inputs/outputs (A side)
1B0 – 1B7, 2B0 – 2B7	2, 3, 5, 6, 8, 9, 11, 12, 13, 14, 16, 17, 19, 20, 22, 23	Data inputs/outputs (B side)
1OE, 2OE	48, 25	Output enables
GND	4, 10, 15, 21, 28, 34, 39, 45	Ground (0V)
VCC	7, 18, 31, 42	Positive supply voltage

LOGIC SYMBOL

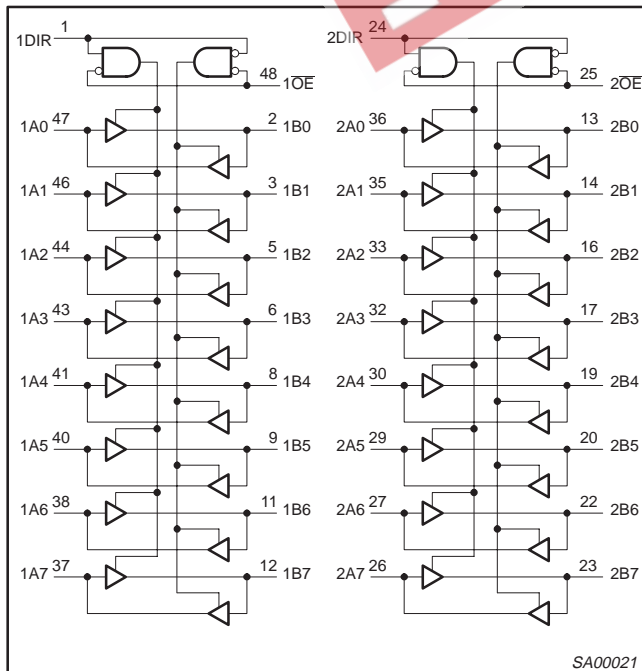

LOGIC SYMBOL (IEEE/IEC)

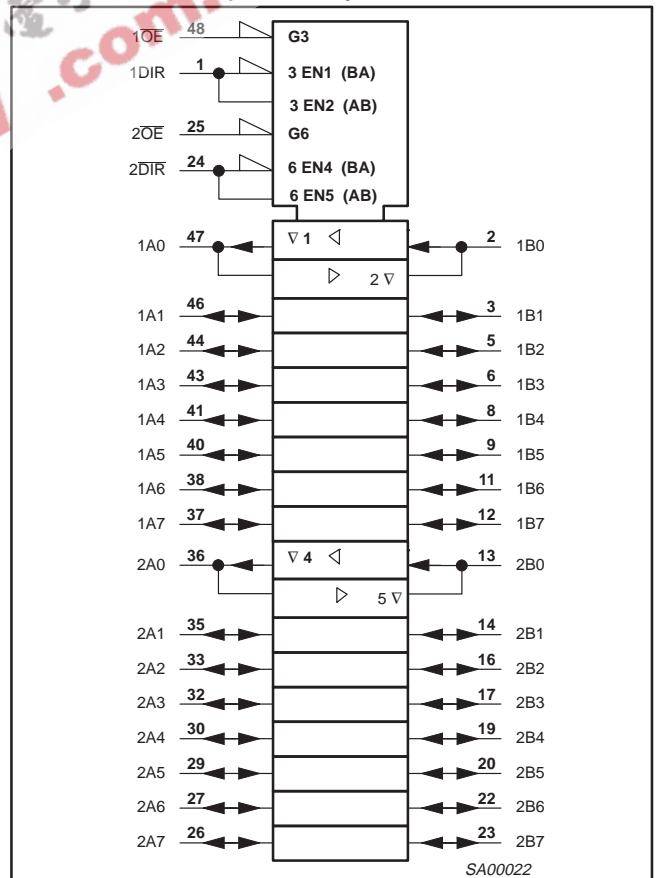

16-bit bus transceiver (3-State)

74ABT16245B
74ABTH16245B

FUNCTION TABLE

INPUTS		INPUTS/OUTPUTS	
nOE	nDIR	nAx	nBx
L	L	A = B	Inputs
L	H	Inputs	B = A
H	X	Z	Z

H = High voltage level

L = Low voltage level

X = Don't care

Z = High impedance "off" scale

ABSOLUTE MAXIMUM RATINGS^{1, 2}

SYMBOL	PARAMETER	CONDITIONS	RATING	UNIT
V _{CC}	DC supply voltage		-0.5 to +7.0	V
I _{IK}	DC input diode current	V _I < 0	-18	mA
V _I	DC input voltage ³		-1.2 to +7.0	V
I _{OK}	DC output diode current	V _O < 0	-50	mA
V _{OUT}	DC output voltage ³	output in Off or High state	-0.5 to +5.5	V
I _{OUT}	DC output current	output in Low state	128	mA
		output in High state	-64	
T _{stg}	Storage temperature range		-65 to 150	°C

NOTES:

- Stresses beyond those listed may cause permanent damage to the device. These are stress ratings only and functional operation of the device at these or any other conditions beyond those indicated under "recommended operating conditions" is not implied. Exposure to absolute-maximum-rated conditions for extended periods may affect device reliability.
- The performance capability of a high-performance integrated circuit in conjunction with its thermal environment can create junction temperatures which are detrimental to reliability. The maximum junction temperature of this integrated circuit should not exceed 150°C.
- The input and output voltage ratings may be exceeded if the input and output current ratings are observed.

RECOMMENDED OPERATING CONDITIONS

SYMBOL	PARAMETER	LIMITS		UNIT
		Min	Max	
V _{CC}	DC supply voltage	4.5	5.5	V
V _I	Input voltage	0	V _{CC}	V
V _{IH}	High-level input voltage	2.0		V
V _{IL}	Low-level Input voltage		0.8	V
I _{OH}	High-level output current		-32	mA
I _{OL}	Low-level output current		64	mA
Δt/Δv	Input transition rise or fall rate	0	10	ns/V
T _{amb}	Operating free-air temperature range	-40	+85	°C

16-bit bus transceiver (3-State)

74ABT16245B
74ABTH16245B

DC ELECTRICAL CHARACTERISTICS

SYMBOL	PARAMETER	TEST CONDITIONS	LIMITS					UNIT
			T _{amb} = +25°C			T _{amb} = -40°C to +85°C		
			Min	Typ	Max	Min	Max	
V _{IK}	Input clamp voltage	V _{CC} = 4.5V; I _{IK} = -18mA		-0.9	-1.2		-1.2	V
V _{OH}	High-level output voltage	V _{CC} = 4.5V; I _{OH} = -3mA; V _I = V _{IL} or V _{IH}	2.5	2.9		2.5		V
		V _{CC} = 5.0V; I _{OH} = -3mA; V _I = V _{IL} or V _{IH}	3.0	3.4		3.0		V
		V _{CC} = 4.5V; I _{OH} = -32mA; V _I = V _{IL} or V _{IH}	2.0	2.4		2.0		V
V _{OL}	Low-level output voltage	V _{CC} = 4.5V; I _{OL} = 64mA; V _I = V _{IL} or V _{IH}		0.42	0.55		0.55	V
I _I	Input leakage current	V _{CC} = 5.5V; V _I = GND or 5.5V		±0.01	±1.0		±1.0	µA
I _{HOLD}	Bus hold current A and B inputs 74ABTH16245B	V _{CC} = 4.5V; V _I = 0.8V	50			50		µA
		V _{CC} = 5.5V; V _I = 2.0V	-75			-75		
		V _{CC} = 5.5V; V _I = 0 to 5.5V	±500					
I _{OFF}	Power-off leakage current	V _{CC} = 0.0V; V _O or V _I ≤ 4.5V		±5.0	±100		±100	µA
I _{PU} /I _{PD}	Power-up/down 3-State output current	V _{CC} = 2.0V; V _O = 0.5V; V _I = GND or V _{CC} ; V _{OE} = Don't care		±5.0	±50		±50	µA
I _{IH} +I _{OZH}	3-State output High current	V _{CC} = 5.5V; V _O = 5.5V; V _I = V _{IL} or V _{IH}		0.1	10		10	µA
I _{IL} +I _{OZL}	3-State output Low current	V _{CC} = 5.5V; V _O = 0.0V; V _I = V _{IL} or V _{IH}		0.1	10		10	µA
I _{CEX}	Output high leakage current	V _{CC} = 5.5V; V _O = 5.5V; V _I = GND or V _{CC}		5.0	50		50	µA
I _O	Output current ¹	V _{CC} = 5.5V; V _O = 2.5V	-50	-92	-180	-50	-180	mA
I _{CCH}	Quiescent supply current	V _{CC} = 5.5V; Outputs High, V _I = GND or V _{CC}		0.30	0.70		0.70	mA
I _{CCL}		V _{CC} = 5.5V; Outputs Low, V _I = GND or V _{CC}		10	19		19	mA
I _{CCZ}		V _{CC} = 5.5V; Outputs 3-State; V _I = GND or V _{CC}		0.30	0.70		0.70	mA
ΔI _{CC}	Additional supply current per input pin ²	Outputs enabled, one data input at 3.4V, other inputs at V _{CC} or GND; V _{CC} = 5.5V		400	700		700	µA
		Outputs disabled, one data input at 3.4V, other inputs at V _{CC} or GND; V _{CC} = 5.5V		100	250		250	µA
		Control pins, outputs disabled, one enable input at 3.4V, other inputs at V _{CC} or GND; V _{CC} = 5.5V		400	700		700	µA

NOTES:

1. Not more than one output should be tested at a time, and the duration of the test should not exceed one second.
2. This is the increase in supply current for each input at 3.4V.
3. This is the bus hold overdrive current required to force the input to the opposite logic state.

16-bit bus transceiver (3-State)

74ABT16245B
74ABTH16245B

AC CHARACTERISTICS

GND = 0V; $t_R = t_F = 2.5\text{ns}$; $C_L = 50\text{pF}$, $R_L = 500\Omega$

SYMBOL	PARAMETER	WAVEFORM	LIMITS					UNIT
			$T_{\text{amb}} = +25^\circ\text{C}$ $V_{\text{CC}} = +5.0\text{V}$			$T_{\text{amb}} = -40^\circ\text{C to } +85^\circ\text{C}$ $V_{\text{CC}} = +5.0\text{V} \pm 0.5\text{V}$		
			Min	Typ	Max	Min	Max	
t_{PLH} t_{PHL}	Propagation delay nAx to nBx or nBx to nAx	1	1.0 1.0	2.0 2.3	3.2 3.5	1.0 1.0	3.5 4.0	ns
t_{PZH} t_{PZL}	Output enable time to High and Low level	2	1.0 1.7	3.1 4.0	4.4 5.2	1.0 1.7	5.1 6.1	ns
t_{PHZ} t_{PLZ}	Output disable time from High and Low level	2	1.7 1.5	3.5 3.2	4.9 4.4	1.7 1.5	5.4 5.0	ns

AC WAVEFORMS

$V_M = 1.5\text{V}$, $V_{\text{IN}} = \text{GND to } 3.0\text{V}$

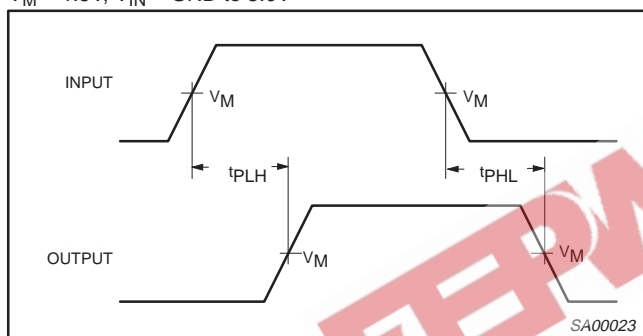

Waveform 1. Input to Output Propagation Delays

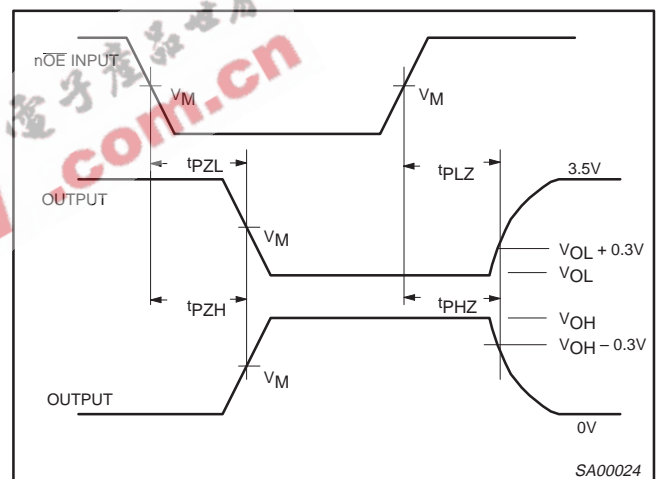

Waveform 2. 3-State Output Enable and Disable Times

16-bit bus transceiver (3-State)

74ABT16245B
74ABTH16245B

TEST CIRCUIT

Test Circuit for 3-State Outputs

Input Pulse Definition
 $V_M = 1.5V$

SWITCH POSITION

TEST	SWITCH
t_{PLZ}	closed
t_{PZL}	closed
All other	open

DEFINITIONS

R_L = Load resistor; see AC CHARACTERISTICS for value.

C_L = Load capacitance includes jig and probe capacitance; see AC CHARACTERISTICS for value.

R_T = Termination resistance should be equal to Z_{OUT} of pulse generators.

FAMILY	INPUT PULSE REQUIREMENTS				
	Amplitude	Rep. Rate	t_w	t_R	t_F
74ABT/H16	3.0V	1MHz	500ns	2.5ns	2.5ns

SA00018

16-Bit bus transceiver (3-State)

74ABT16245B
74ABTH16245B

SSOP48: plastic shrink small outline package; 48 leads; body width 7.5 mm

SOT370-1

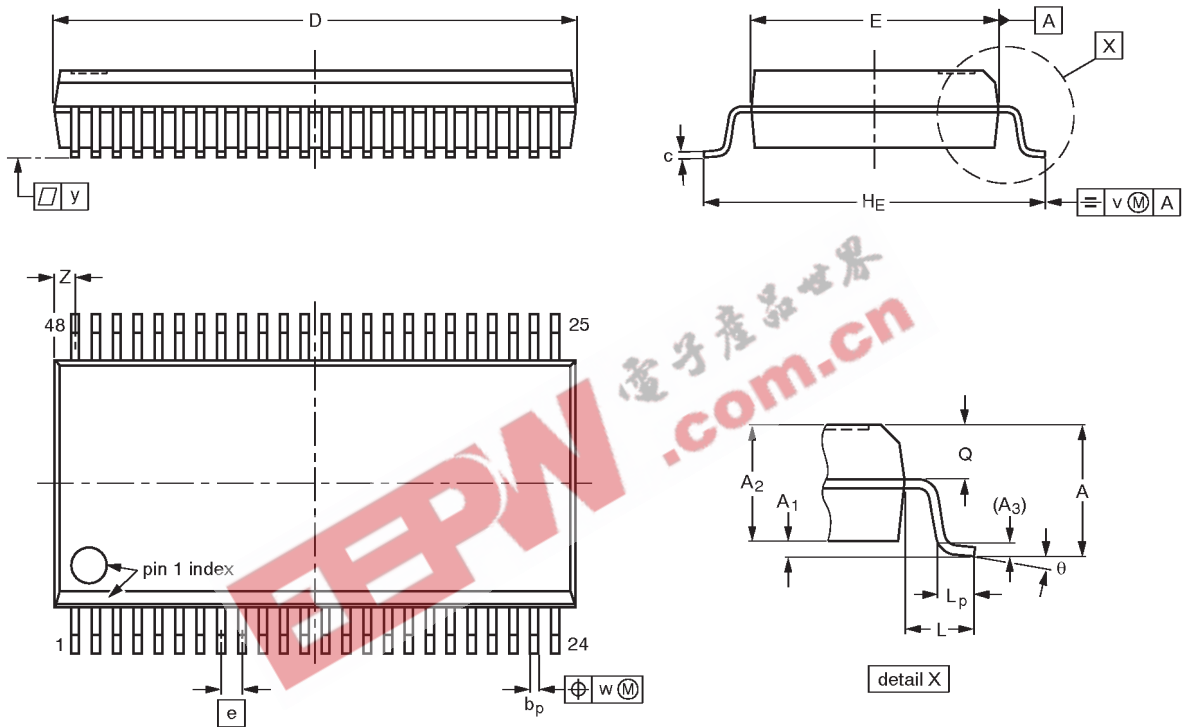

DIMENSIONS (mm are the original dimensions)

UNIT	A max.	A ₁	A ₂	A ₃	b _p	c	D ⁽¹⁾	E ⁽¹⁾	e	H _E	L	L _p	Q	v	w	y	Z ⁽¹⁾	θ
mm	2.8	0.4 0.2	2.35 2.20	0.25	0.3 0.2	0.22 0.13	16.00 15.75	7.6 7.4	0.635	10.4 10.1	1.4	1.0 0.6	1.2 1.0	0.25	0.18	0.1	0.85 0.40	8° 0°

Note

1. Plastic or metal protrusions of 0.25 mm maximum per side are not included.

OUTLINE VERSION	REFERENCES				EUROPEAN PROJECTION	ISSUE DATE
	IEC	JEDEC	EIAJ			
SOT370-1		MO-118AA				93-11-02 95-02-04

16-Bit bus transceiver (3-State)

74ABT16245B
74ABTH16245B

TSSOP48: plastic thin shrink small outline package; 48 leads; body width 6.1mm

SOT362-1

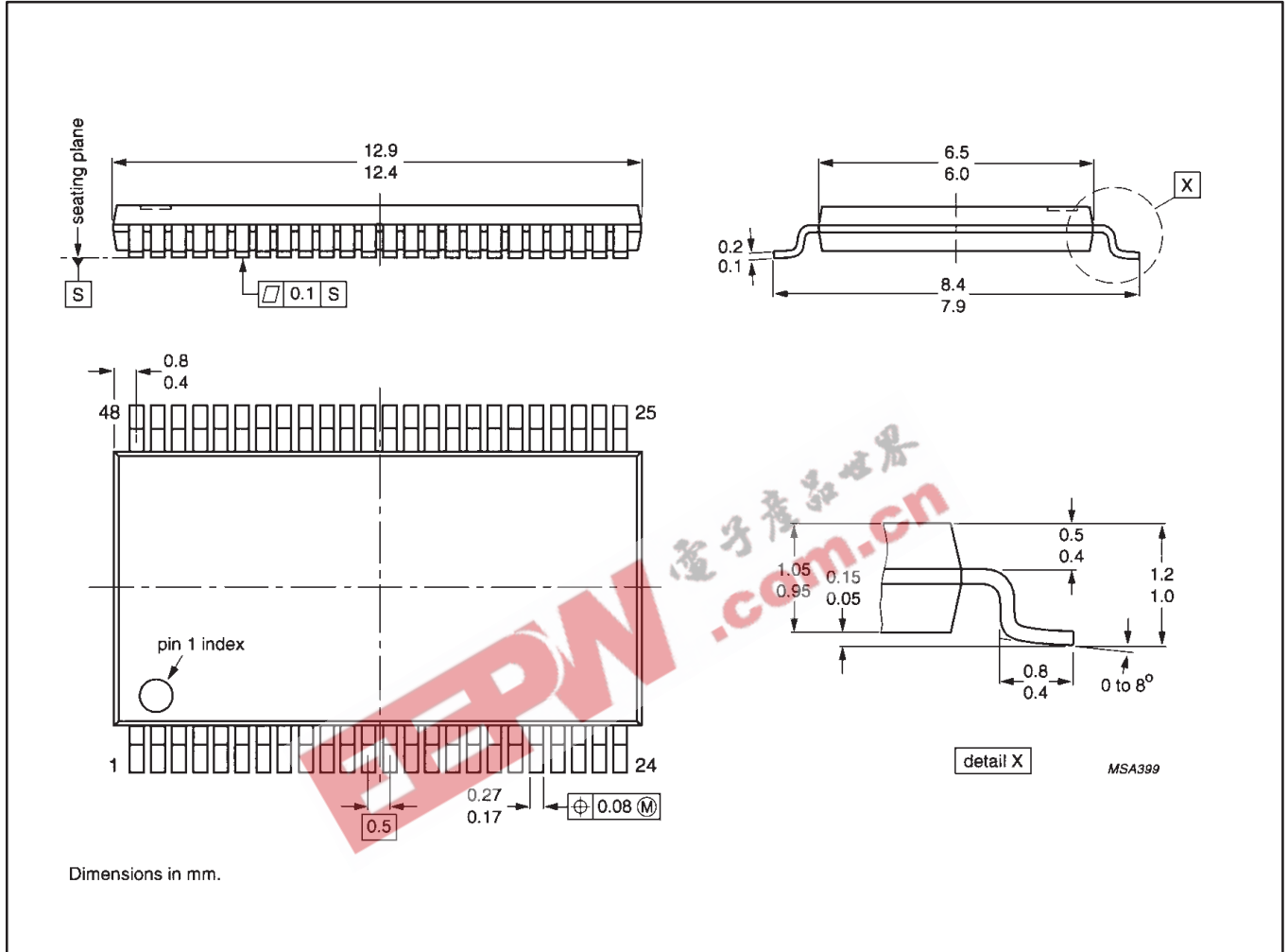

16-Bit bus transceiver (3-State)

74ABT16245B
74ABTH16245B

NOTES



16-Bit bus transceiver (3-State)

74ABT16245B
74ABTH16245B

Data sheet status

Data sheet status	Product status	Definition [1]
Objective specification	Development	This data sheet contains the design target or goal specifications for product development. Specification may change in any manner without notice.
Preliminary specification	Qualification	This data sheet contains preliminary data, and supplementary data will be published at a later date. Philips Semiconductors reserves the right to make changes at any time without notice in order to improve design and supply the best possible product.
Product specification	Production	This data sheet contains final specifications. Philips Semiconductors reserves the right to make changes at any time without notice in order to improve design and supply the best possible product.

[1] Please consult the most recently issued datasheet before initiating or completing a design.

Definitions

Short-form specification — The data in a short-form specification is extracted from a full data sheet with the same type number and title. For detailed information see the relevant data sheet or data handbook.

Limiting values definition — Limiting values given are in accordance with the Absolute Maximum Rating System (IEC 134). Stress above one or more of the limiting values may cause permanent damage to the device. These are stress ratings only and operation of the device at these or at any other conditions above those given in the Characteristics sections of the specification is not implied. Exposure to limiting values for extended periods may affect device reliability.

Application information — Applications that are described herein for any of these products are for illustrative purposes only. Philips Semiconductors make no representation or warranty that such applications will be suitable for the specified use without further testing or modification.

Disclaimers

Life support — These products are not designed for use in life support appliances, devices or systems where malfunction of these products can reasonably be expected to result in personal injury. Philips Semiconductors customers using or selling these products for use in such applications do so at their own risk and agree to fully indemnify Philips Semiconductors for any damages resulting from such application.

Right to make changes — Philips Semiconductors reserves the right to make changes, without notice, in the products, including circuits, standard cells, and/or software, described or contained herein in order to improve design and/or performance. Philips Semiconductors assumes no responsibility or liability for the use of any of these products, conveys no license or title under any patent, copyright, or mask work right to these products, and makes no representations or warranties that these products are free from patent, copyright, or mask work right infringement, unless otherwise specified.

Philips Semiconductors
811 East Arques Avenue
P.O. Box 3409
Sunnyvale, California 94088-3409
Telephone 800-234-7381

© Copyright Philips Electronics North America Corporation 1998
All rights reserved. Printed in U.S.A.

print code

Date of release: 05-96

Document order number:

9397-750-03486

Let's make things better.