

# DATA SHEET

EEPW 电子產品世界  
.com.cn

**74LVT244A**

**3.3V Octal buffer/line driver (3-State)**

Product specification  
Supersedes data of 1995 Nov 14  
IC23 Data Handbook

1998 Feb 19

## 3.3V Octal buffer/line driver (3-State)

## 74LVT244A

## FEATURES

- Octal bus interface
- 3-State buffers
- Output capability: +64mA/-32mA
- TTL input and output switching levels
- Input and output interface capability to systems at 5V supply
- Bus-hold data inputs eliminate the need for external pull-up resistors to hold unused inputs
- Power-up 3-State
- Live insertion/extraction permitted
- No bus current loading when output is tied to 5V bus
- Latch-up protection exceeds 500mA per JEDEC Std 17
- ESD protection exceeds 2000V per MIL STD 883 Method 3015 and 200V per Machine Model

## DESCRIPTION

The LVT244A is a high-performance BiCMOS product designed for  $V_{CC}$  operation at 3.3V.

This device is an octal buffer that is ideal for driving bus lines. The device features two Output Enables ( $\overline{OE}1$ ,  $\overline{OE}2$ ), each controlling four of the 3-State outputs.

## QUICK REFERENCE DATA

SYMBOL	PARAMETER	CONDITIONS $T_{amb} = 25^{\circ}\text{C}$ ; $GND = 0V$	TYPICAL	UNIT
$t_{PLH}$ $t_{PHL}$	Propagation delay $nAx$ to $nYx$	$C_L = 50\text{pF}$ ; $V_{CC} = 3.3V$	2.5 2.6	ns
$C_{IN}$	Input capacitance	$V_I = 0V$ or $3.0V$	4	pF
$C_{OUT}$	Output capacitance	Outputs disabled; $V_O = 0V$ or $3.0V$	8	pF
$I_{CCZ}$	Total supply current	Outputs disabled; $V_{CC} = 3.6V$	0.13	mA

## ORDERING INFORMATION

PACKAGES	TEMPERATURE RANGE	OUTSIDE NORTH AMERICA	NORTH AMERICA	DWG NUMBER
20-Pin Plastic SOL	$-40^{\circ}\text{C}$ to $+85^{\circ}\text{C}$	74LVT244A D	74LVT244A D	SOT163-1
20-Pin Plastic SSOP Type II	$-40^{\circ}\text{C}$ to $+85^{\circ}\text{C}$	74LVT244A DB	74LVT244A DB	SOT339-1
20-Pin Plastic TSSOP Type I	$-40^{\circ}\text{C}$ to $+85^{\circ}\text{C}$	74LVT244A PW	7LVT244APW DH	SOT360-1

## PIN CONFIGURATION

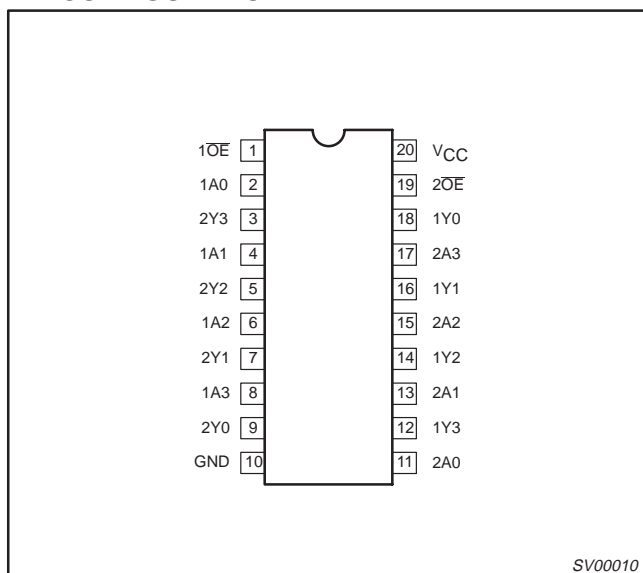

## PIN DESCRIPTION

PIN NUMBER	SYMBOL	NAME AND FUNCTION
2, 4, 6, 8	1A0 – 1A3	Data inputs
11, 13, 15, 17	2A0 – 2A3	Data inputs
18, 16, 14, 12	1Y0 – 1Y3	Data outputs
9, 7, 5, 3	2Y0 – 2Y3	Data outputs
1, 19	$1\overline{OE}$ , $2\overline{OE}$	Output enables
10	GND	Ground (0V)
20	$V_{CC}$	Positive supply voltage

### 3.3V Octal buffer/line driver (3-State)

### 74LVT244A

#### LOGIC SYMBOL

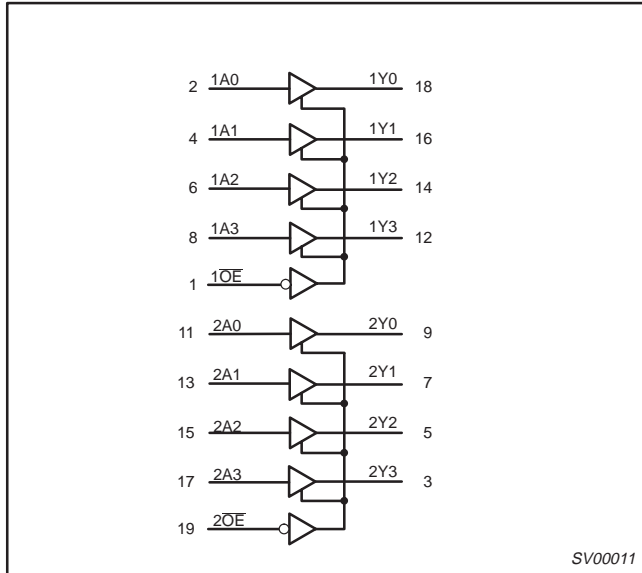

#### LOGIC SYMBOL (IEEE/IEC)

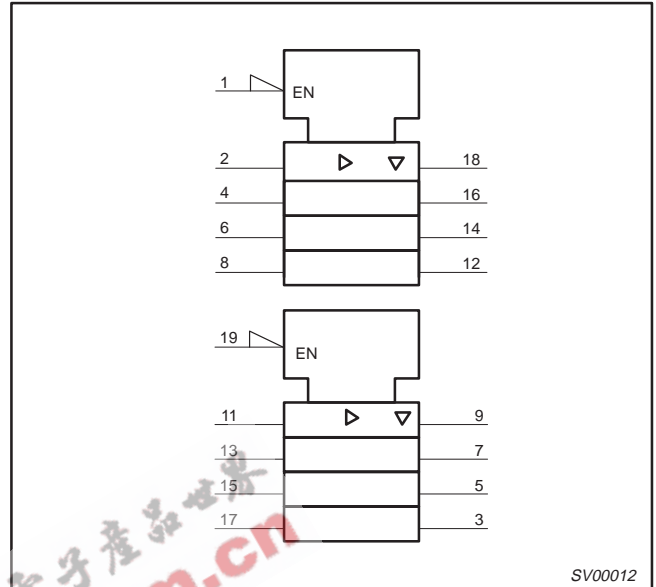

#### FUNCTION TABLE

INPUTS		OUTPUTS
$\overline{nOE1}$	$nAx$	$nYx$
L	L	L
L	H	H
H	X	Z

H = High voltage level  
 L = Low voltage level  
 X = Don't care  
 Z = High impedance "off" state

#### ABSOLUTE MAXIMUM RATINGS<sup>1, 2</sup>

SYMBOL	PARAMETER	CONDITIONS	RATING	UNIT
$V_{CC}$	DC supply voltage		-0.5 to +4.6	V
$V_I$	DC input voltage <sup>3</sup>		-0.5 to +7.0	V
$V_{OUT}$	DC output voltage <sup>3</sup>	Output in Off or High state	-0.5 to +7.0	V
$I_{OUT}$	DC output current	Output in Low state	128	mA
		Output in High state	-64	
$I_{IK}$	DC input diode current	$V_I < 0$	-50	mA
$I_{OK}$	DC output diode current	$V_O < 0$	-50	mA
$T_{stg}$	Storage temperature range		-65 to 150	°C

#### NOTES:

- Stresses beyond those listed may cause permanent damage to the device. These are stress ratings only and functional operation of the device at these or any other conditions beyond those indicated under "recommended operating conditions" is not implied. Exposure to absolute-maximum-rated conditions for extended periods may affect device reliability.
- The performance capability of a high-performance integrated circuit in conjunction with its thermal environment can create junction temperatures which are detrimental to reliability. The maximum junction temperature of this integrated circuit should not exceed 150°C.
- The input and output voltage ratings may be exceeded if the input and output current ratings are observed.

## 3.3V Octal buffer/line driver (3-State)

74LVT244A

## RECOMMENDED OPERATING CONDITIONS

SYMBOL	PARAMETER	LIMITS		UNIT
		MIN	MAX	
$V_{CC}$	DC supply voltage	2.7	3.6	V
$V_I$	Input voltage	0	5.5	V
$V_{IH}$	High-level input voltage	2.0		V
$V_{IL}$	Low-level input voltage		0.8	V
$I_{OH}$	High-level output current		-32	mA
$I_{OL}$	Low-level output current		32	mA
	Low-level output current; current duty cycle $\leq 50\%$ , $f \geq 1$ kHz		64	
$\Delta t/\Delta v$	Input transition rise or fall rate; outputs enabled		10	ns/V
$T_{amb}$	Operating free-air temperature range	-40	+85	$^{\circ}$ C

## DC ELECTRICAL CHARACTERISTICS

SYMBOL	PARAMETER	TEST CONDITIONS	LIMITS			UNIT
			Temp = -40 $^{\circ}$ C to +85 $^{\circ}$ C			
			MIN	TYP <sup>1</sup>	MAX	
$V_{IK}$	Input clamp voltage	$V_{CC} = 2.7V$ ; $I_{IK} = -18mA$		-0.9	-1.2	V
$V_{OH}$	High-level output voltage	$V_{CC} = 2.7$ to $3.6V$ ; $I_{OH} = -100\mu A$	$V_{CC}-0.2$	$V_{CC}-0.1$		V
		$V_{CC} = 2.7V$ ; $I_{OH} = -8mA$	2.4	2.5		
		$V_{CC} = 3.0V$ ; $I_{OH} = -32mA$	2.0	2.2		
$V_{OL}$	Low-level output voltage	$V_{CC} = 2.7V$ ; $I_{OL} = 100\mu A$		0.1	0.2	V
		$V_{CC} = 2.7V$ ; $I_{OL} = 24mA$		0.3	0.5	
		$V_{CC} = 3.0V$ ; $I_{OL} = 16mA$		0.25	0.4	
		$V_{CC} = 3.0V$ ; $I_{OL} = 32mA$		0.3	0.5	
		$V_{CC} = 3.0V$ ; $I_{OL} = 64mA$		0.4	0.55	
$I_I$	Input leakage current	$V_{CC} = 0$ or $3.6V$ ; $V_I = 5.5V$		0.1	10	$\mu A$
		$V_{CC} = 3.6V$ ; $V_I = V_{CC}$ or GND	Control pins	$\pm 0.1$	$\pm 1$	
		$V_{CC} = 3.6V$ ; $V_I = V_{CC}$	Data Pins <sup>4</sup>	0.1	1	
		$V_{CC} = 3.6V$ ; $V_I = 0$		-1	-5	
$I_{OFF}$	Output off current	$V_{CC} = 0V$ ; $V_I$ or $V_O = 0$ to $4.5V$		1	$\pm 100$	$\mu A$
$I_{HOLD}$	Bus Hold current A inputs <sup>6</sup>	$V_{CC} = 3V$ ; $V_I = 0.8V$	75	150		$\mu A$
		$V_{CC} = 3V$ ; $V_I = 2.0V$	-75	-150		
		$V_{CC} = 0V$ to $3.6V$ ; $V_{CC} = 3.6V$	$\pm 500$			
$I_{EX}$	Current into an output in the High state when $V_O > V_{CC}$	$V_O = 5.5V$ ; $V_{CC} = 3.0V$		60	125	$\mu A$
$I_{PU/PD}$	Power up/down 3-State output current <sup>3</sup>	$V_{CC} \leq 1.2V$ ; $V_O = 0.5V$ to $V_{CC}$ ; $V_I = GND$ or $V_{CC}$ ; OE/OE = Don't care		$\pm 1$	$\pm 100$	$\mu A$
$I_{OZH}$	3-State output high current	$V_{CC} = 3.6V$ ; $V_O = 3V$ ; $V_I = V_{IL}$ or $V_{IH}$		1	5	$\mu A$
$I_{OZL}$	3-State output low current	$V_{CC} = 3.6V$ ; $V_O = 0.5V$ ; $V_I = V_{IL}$ or $V_{IH}$		-1	-5	$\mu A$
$I_{CCH}$	Quiescent supply current	$V_{CC} = 3.6V$ ; Outputs High, $V_I = GND$ or $V_{CC}$ , $I_O = 0$		0.13	0.19	mA
$I_{CCL}$		$V_{CC} = 3.6V$ ; Outputs Low, $V_I = GND$ or $V_{CC}$ , $I_O = 0$		3	12	
$I_{CCZ}$		$V_{CC} = 3.6V$ ; Outputs Disabled; $V_I = GND$ or $V_{CC}$ , $I_O = 0$ <sup>5</sup>		0.13	0.19	
$\Delta I_{CC}$	Additional supply current per input pin <sup>2</sup>	$V_{CC} = 3V$ to $3.6V$ ; One input at $V_{CC}-0.6V$ , Other inputs at $V_{CC}$ or GND		0.1	0.2	mA

## NOTES:

- All typical values are at  $T_{amb} = 25^{\circ}$ C.
- This is the increase in supply current for each input at the specified voltage level other than  $V_{CC}$  or GND
- This parameter is valid for any  $V_{CC}$  between 0V and 1.2V with a transition time of up to 10msec. From  $V_{CC} = 1.2V$  to  $V_{CC} = 3.3V \pm 0.3V$  a transition time of 100 $\mu$ sec is permitted. This parameter is valid for  $T_{amb} = 25^{\circ}$ C only.
- Unused pins at  $V_{CC}$  or GND.
- $I_{CCZ}$  is measured with outputs pulled to  $V_{CC}$  or GND.
- This is the bus hold overdrive current required to force the input to the opposite logic state.

### 3.3V Octal buffer/line driver (3-State)

### 74LVT244A

#### AC CHARACTERISTICS

GND = 0V;  $t_R = t_F = 2.5\text{ns}$ ;  $C_L = 50\text{pF}$ ;  $R_L = 500\Omega$ ;  $T_{\text{amb}} = -40^\circ\text{C}$  to  $+85^\circ\text{C}$ .

SYMBOL	PARAMETER	WAVEFORM	LIMITS				UNIT
			$V_{CC} = 3.3V \pm 0.3V$			$V_{CC} = 2.7V$	
			MIN	TYP <sup>1</sup>	MAX	MAX	
$t_{PLH}$ $t_{PHL}$	Propagation delay nAx to nYx	1	1 1	2.5 2.6	4.1 4.1	5.0 5.1	ns
$t_{PZH}$ $t_{PZL}$	Output enable time to High and Low level	2	1 1.1	3.2 3.1	5.2 5.2	6.3 6.7	ns
$t_{PHZ}$ $t_{PLZ}$	Output disable time from High and Low level	2	1.9 1.8	3.3 3.3	5.6 5.1	6.3 5.6	ns

**NOTE:**

1. All typical values are at  $V_{CC} = 3.3V$  and  $T_{\text{amb}} = 25^\circ\text{C}$ .

#### AC WAVEFORMS

$V_M = 1.5V$ ,  $V_{IN} = \text{GND}$  to  $2.7V$

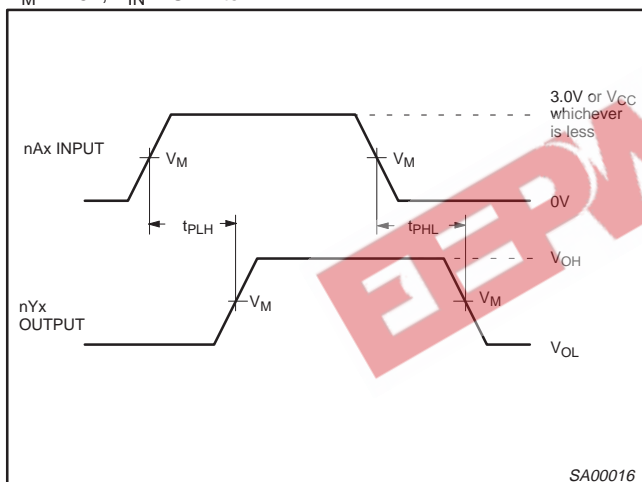

Waveform 1. Input (nAx) to Output (nYx) Propagation Delays

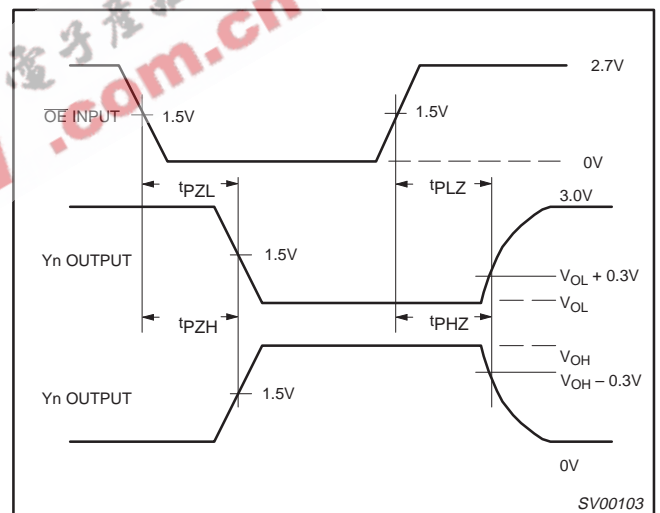

Waveform 2. 3-State Output Enable and Disable Times

### 3.3V Octal buffer/line driver (3-State)

### 74LVT244A

#### TEST CIRCUIT AND WAVEFORMS

Test Circuit for 3-State Outputs

$V_M = 1.5V$   
Input Pulse Definition

**SWITCH POSITION**

TEST	SWITCH
$t_{PLH}/t_{PHL}$	Open
$t_{PLZ}/t_{PZL}$	6V
$t_{PHZ}/t_{PZH}$	GND

**DEFINITIONS**

$R_L$  = Load resistor; see AC CHARACTERISTICS for value.

$C_L$  = Load capacitance includes jig and probe capacitance; see AC CHARACTERISTICS for value.

$R_T$  = Termination resistance should be equal to  $Z_{OUT}$  of pulse generators.

FAMILY	INPUT PULSE REQUIREMENTS				
	Amplitude	Rep. Rate	$t_W$	$t_R$	$t_F$
74LVT	2.7V	$\leq 10MHz$	500ns	$\leq 2.5ns$	$\leq 2.5ns$

SV00092

3.3V Octal buffer/line driver (3-State)

74LVT244A

SO20: plastic small outline package; 20 leads; body width 7.5 mm

SOT163-1

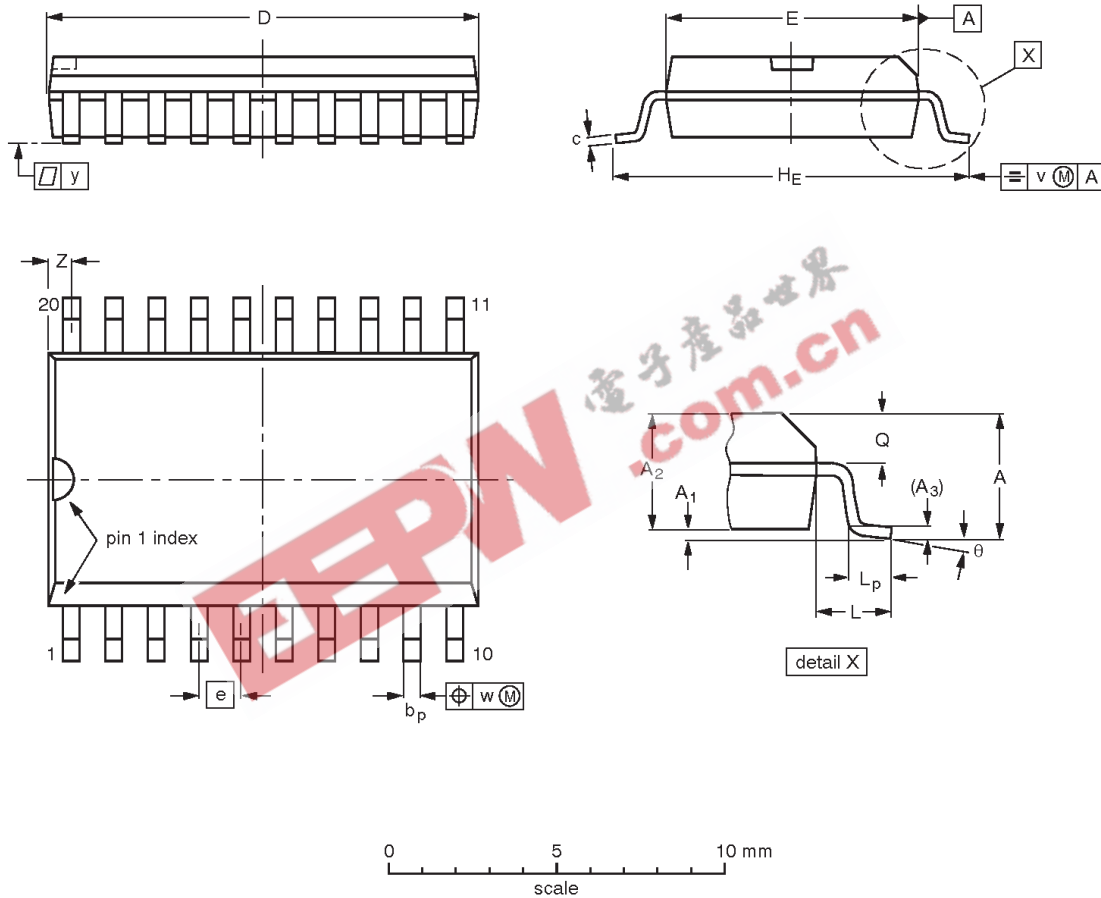

DIMENSIONS (inch dimensions are derived from the original mm dimensions)

UNIT	A max.	A <sub>1</sub>	A <sub>2</sub>	A <sub>3</sub>	b <sub>p</sub>	c	D <sup>(1)</sup>	E <sup>(1)</sup>	e	H <sub>E</sub>	L	L <sub>p</sub>	Q	v	w	y	z <sup>(1)</sup>	θ
mm	2.65	0.30 0.10	2.45 2.25	0.25	0.49 0.36	0.32 0.23	13.0 12.6	7.6 7.4	1.27	10.65 10.00	1.4	1.1 0.4	1.1 1.0	0.25	0.25	0.1	0.9 0.4	8° 0°
inches	0.10	0.012 0.004	0.096 0.089	0.01	0.019 0.014	0.013 0.009	0.51 0.49	0.30 0.29	0.050	0.42 0.39	0.055	0.043 0.016	0.043 0.039	0.01	0.01	0.004	0.035 0.016	

Note

1. Plastic or metal protrusions of 0.15 mm maximum per side are not included.

OUTLINE VERSION	REFERENCES				EUROPEAN PROJECTION	ISSUE DATE
	IEC	JEDEC	EIAJ			
SOT163-1	075E04	MS-013AC				92-11-17 95-01-24

3.3V Octal buffer/line driver (3-State)

74LVT244A

SSOP20: plastic shrink small outline package; 20 leads; body width 5.3 mm

SOT339-1

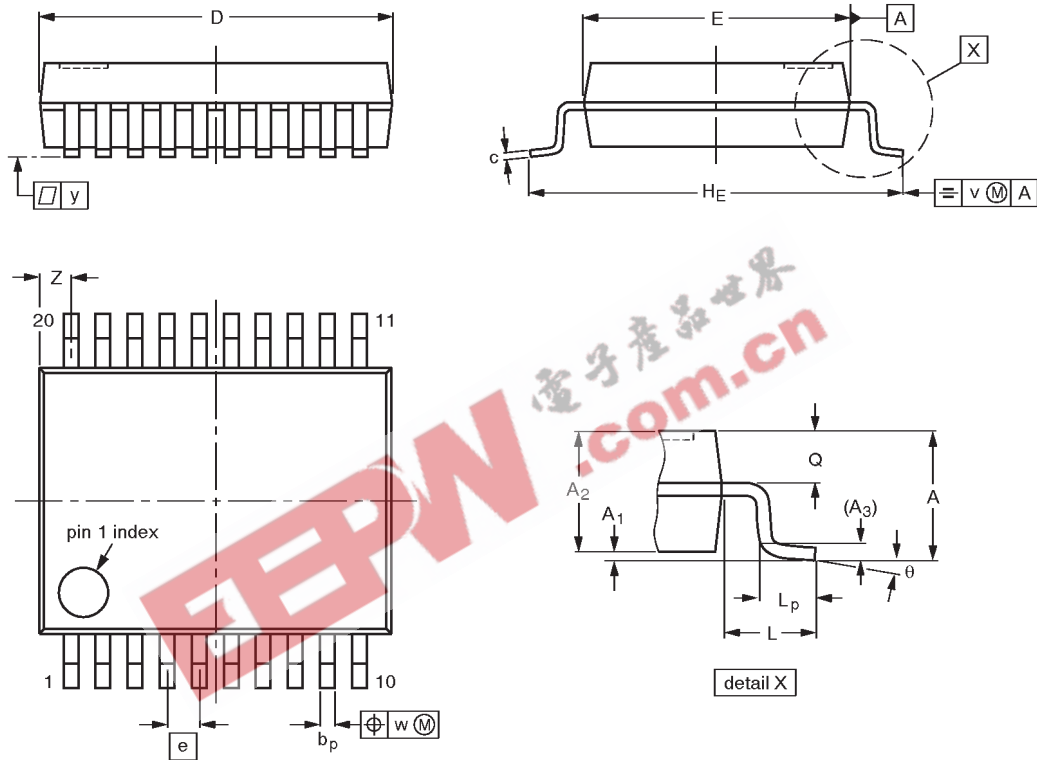

DIMENSIONS (mm are the original dimensions)

UNIT	A max.	A <sub>1</sub>	A <sub>2</sub>	A <sub>3</sub>	b <sub>p</sub>	c	D <sup>(1)</sup>	E <sup>(1)</sup>	e	H <sub>E</sub>	L	L <sub>p</sub>	Q	v	w	y	z <sup>(1)</sup>	θ
mm	2.0	0.21 0.05	1.80 1.65	0.25	0.38 0.25	0.20 0.09	7.4 7.0	5.4 5.2	0.65	7.9 7.6	1.25	1.03 0.63	0.9 0.7	0.2	0.13	0.1	0.9 0.5	8° 0°

Note

1. Plastic or metal protrusions of 0.20 mm maximum per side are not included.

OUTLINE VERSION	REFERENCES				EUROPEAN PROJECTION	ISSUE DATE
	IEC	JEDEC	EIAJ			
SOT339-1		MO-150AE				93-09-08 95-02-04



3.3V Octal buffer/line driver (3-State)

74LVT244A

TSSOP20: plastic thin shrink small outline package; 20 leads; body width 4.4 mm

SOT360-1

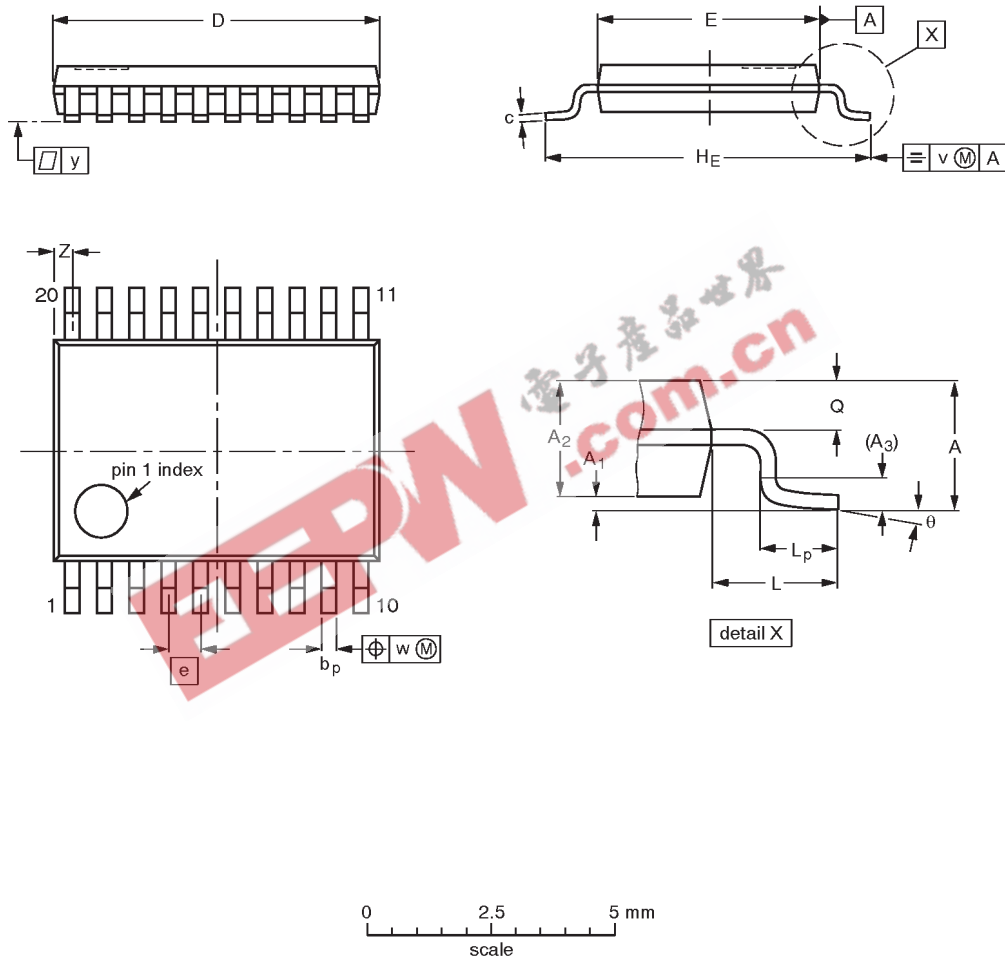

DIMENSIONS (mm are the original dimensions)

UNIT	A max.	A <sub>1</sub>	A <sub>2</sub>	A <sub>3</sub>	b <sub>p</sub>	c	D <sup>(1)</sup>	E <sup>(2)</sup>	e	H <sub>E</sub>	L	L <sub>p</sub>	Q	v	w	y	Z <sup>(1)</sup>	θ
mm	1.10	0.15 0.05	0.95 0.80	0.25	0.30 0.19	0.2 0.1	6.6 6.4	4.5 4.3	0.65	6.6 6.2	1.0	0.75 0.50	0.4 0.3	0.2	0.13	0.1	0.5 0.2	8° 0°

Notes

1. Plastic or metal protrusions of 0.15 mm maximum per side are not included.
2. Plastic interlead protrusions of 0.25 mm maximum per side are not included.

OUTLINE VERSION	REFERENCES				EUROPEAN PROJECTION	ISSUE DATE
	IEC	JEDEC	EIAJ			
SOT360-1		MO-153AC				93-06-16 95-02-04

## 3.3V Octal buffer/line driver (3-State)

74LVT244A

## Data sheet status

Data sheet status	Product status	Definition [1]
Objective specification	Development	This data sheet contains the design target or goal specifications for product development. Specification may change in any manner without notice.
Preliminary specification	Qualification	This data sheet contains preliminary data, and supplementary data will be published at a later date. Philips Semiconductors reserves the right to make changes at any time without notice in order to improve design and supply the best possible product.
Product specification	Production	This data sheet contains final specifications. Philips Semiconductors reserves the right to make changes at any time without notice in order to improve design and supply the best possible product.

[1] Please consult the most recently issued datasheet before initiating or completing a design.

## Definitions

**Short-form specification** — The data in a short-form specification is extracted from a full data sheet with the same type number and title. For detailed information see the relevant data sheet or data handbook.

**Limiting values definition** — Limiting values given are in accordance with the Absolute Maximum Rating System (IEC 134). Stress above one or more of the limiting values may cause permanent damage to the device. These are stress ratings only and operation of the device at these or at any other conditions above those given in the Characteristics sections of the specification is not implied. Exposure to limiting values for extended periods may affect device reliability.

**Application information** — Applications that are described herein for any of these products are for illustrative purposes only. Philips Semiconductors make no representation or warranty that such applications will be suitable for the specified use without further testing or modification.

## Disclaimers

**Life support** — These products are not designed for use in life support appliances, devices or systems where malfunction of these products can reasonably be expected to result in personal injury. Philips Semiconductors customers using or selling these products for use in such applications do so at their own risk and agree to fully indemnify Philips Semiconductors for any damages resulting from such application.

**Right to make changes** — Philips Semiconductors reserves the right to make changes, without notice, in the products, including circuits, standard cells, and/or software, described or contained herein in order to improve design and/or performance. Philips Semiconductors assumes no responsibility or liability for the use of any of these products, conveys no license or title under any patent, copyright, or mask work right to these products, and makes no representations or warranties that these products are free from patent, copyright, or mask work right infringement, unless otherwise specified.

Philips Semiconductors  
811 East Arques Avenue  
P.O. Box 3409  
Sunnyvale, California 94088-3409  
Telephone 800-234-7381

© Copyright Philips Electronics North America Corporation 1998  
All rights reserved. Printed in U.S.A.

print code

Date of release: 05-96

Document order number:

9397-750-03519

*Let's make things better.*