



# TDA7429L

## 3 BAND EQUALIZER AUDIO PROCESSOR WITH SUBWOOFER CONTROL

- 3 STEREO INPUTS
- AUXILIARY MONO INPUT
- INPUT ATTENUATION CONTROL IN 0.5dB STEP
- TREBLE MIDDLE AND BASS CONTROL
- FOUR SPEAKERS ATTENUATORS:
  - 4 INDEPENDENT SPEAKERS CONTROL IN 1dB STEPS FOR BALANCE FACILITY
  - INDEPENDENT MUTE FUNCTION
- SUBWOOFER OUTPUT (L+R) CONTROLLED IN 1dB STEP INPUTS
- ALL FUNCTIONS PROGRAMMABLE VIA SERIAL BUS



an additional subwoofer control.

The AC signal setting is obtained by resistor networks and switches combined with operational amplifiers. Thanks to the used BIPOLAR/CMOS Technology, Low Distortion, Low Noise and DC stepping are obtained.

### DESCRIPTION

The TDA7429L is volume tone (bass middle and treble) balance (Left/Right) processors for quality audio applications in TV and Hi-Fi systems, providing also

Figure 1. Test Circuit

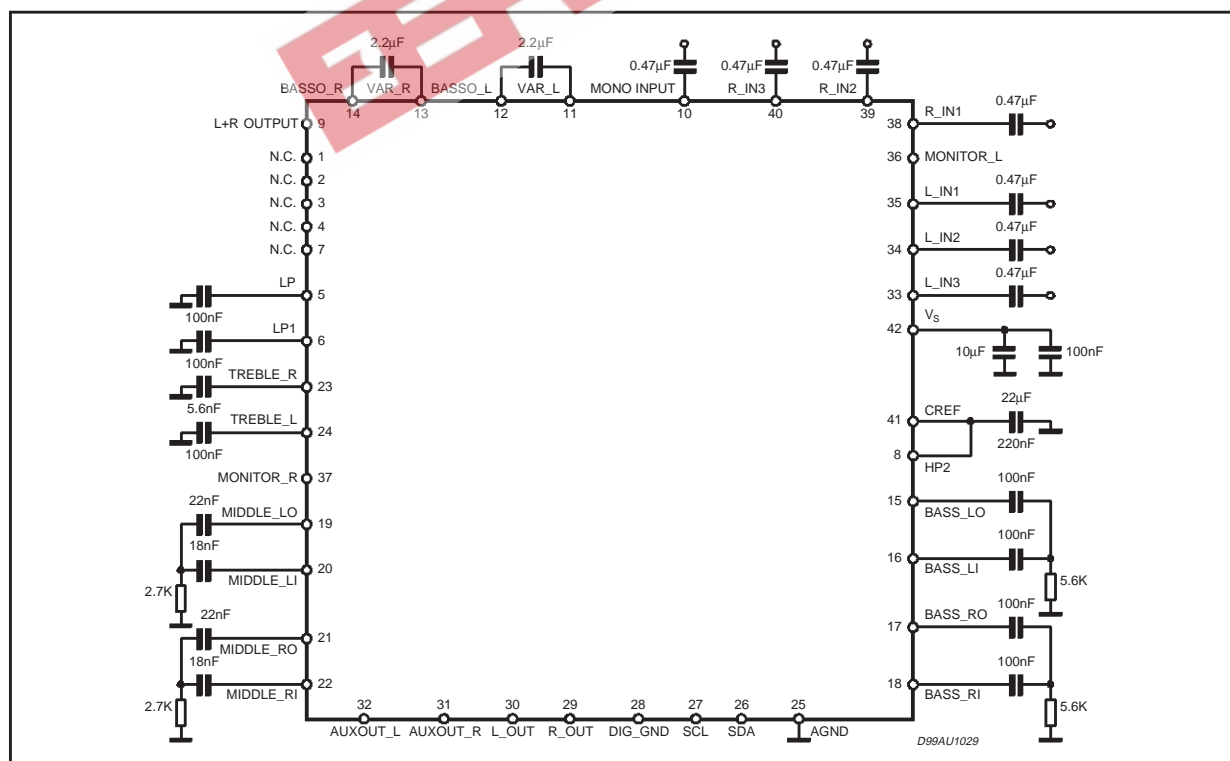

Figure 2. Pin Connection

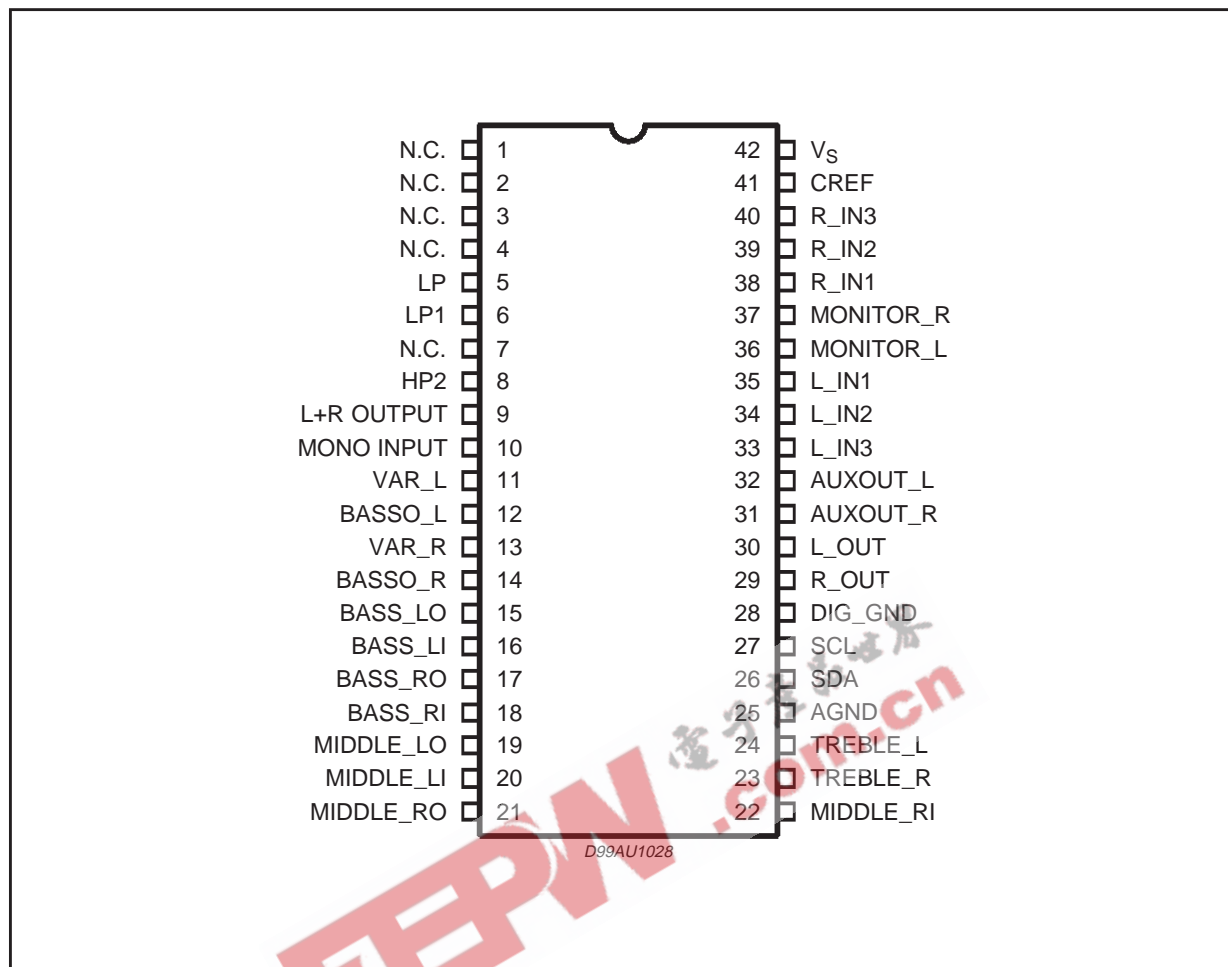

Table 1. Quick Reference Data

Symbol	Parameter	Min.	Typ.	Max.	Unit
VS	Supply Voltage	7	9	10.2	V
VCL	Max. input signal handling	2			Vrms
THD	Total Harmonic Distortion V = 1Vrms f = 1KHz		0.01	0.1	%
S/N	Signal to Noise Ratio V out = 1Vrms (mode = OFF)		106		dB
Sc	Channel Separation f = 1KHz		90		dB
	Treble Control (2db step)	-14		+14	dB
	Middle Control (2db step)	-14		+14	dB
	Bass Control (2dB step)	-14		+14	dB
	Balance Control 1dB step (LCH, RCH)	-79		0	dB
	Mute Attenuation		100		dB

Figure 3. Block Diagram.

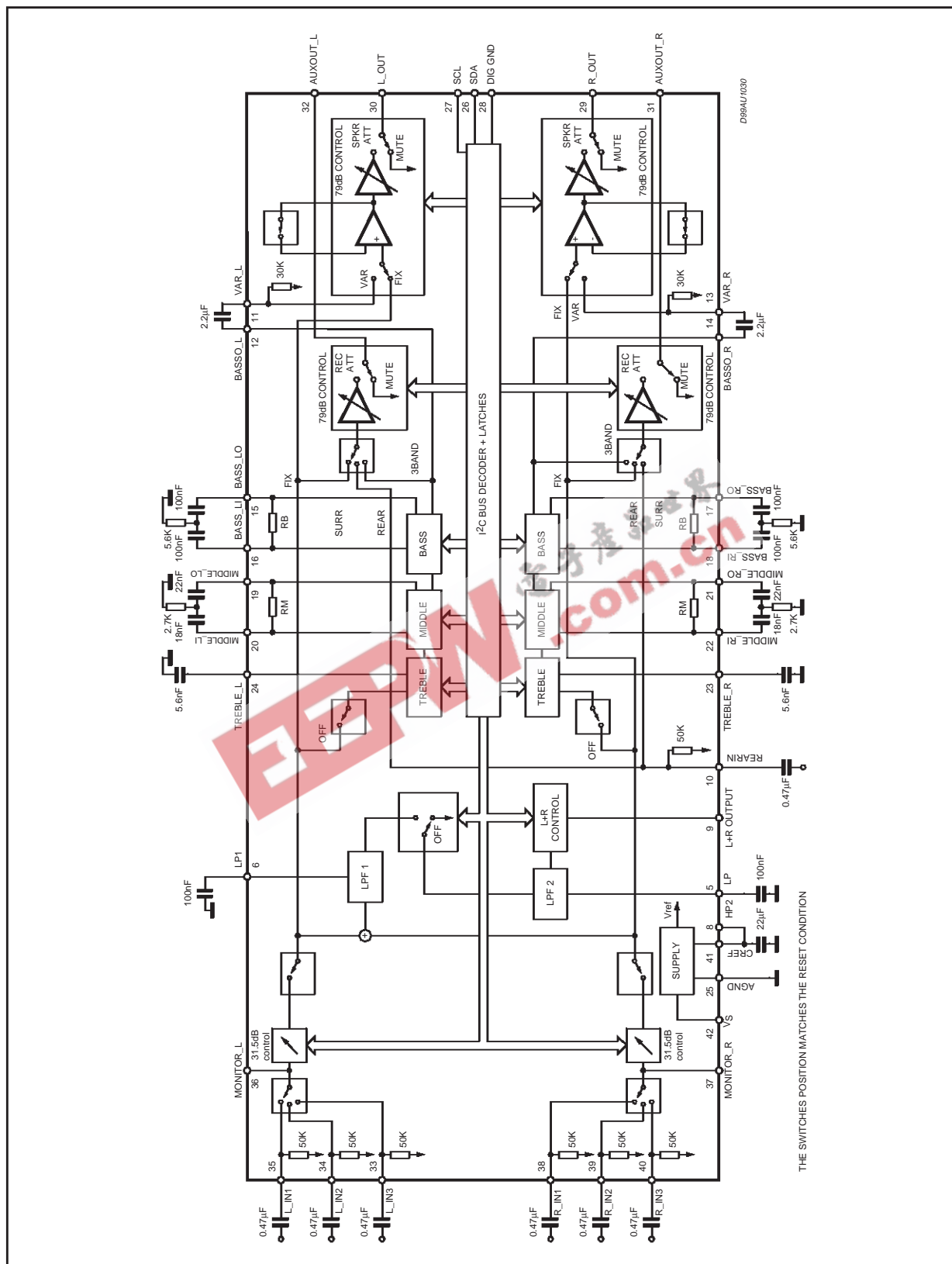

Table 2. Thermal Data

Symbol	Description	Value	Unit
R <sub>th j-pins</sub>	Thermal Resistance Junction-pins	Max. 85	°C/W

Table 3. Absolute Maximum Ratings

Symbol	Parameter	Value	Unit
V <sub>S</sub>	Operating Supply Voltage	11	V
T <sub>amb</sub>	Operating Ambient Temperature	-10 to 85	°C
T <sub>stg</sub>	Storage Temperature Range	-55 to +150	°C

Table 4. Electrical Characteristics

(refer to the test circuit T<sub>amb</sub> = 25°C, V<sub>S</sub> = 9V, R<sub>L</sub> = 10KΩ, V<sub>in</sub> = 1V<sub>rms</sub>; R<sub>G</sub> = 600Ω, all controls flat (G = 0dB), L+R CTRL = +4dB, MODE = OFF; f = 1KHz unless otherwise specified).

Symbol	Parameter	Test Condition	Min.	Typ.	Max.	Unit
SUPPLY						
V <sub>S</sub>	Supply Voltage		7	9	10.2	V
I <sub>S</sub>	Supply Current		10	18	26	mA
SVR	Ripple Rejection	L <sub>CH</sub> / R <sub>CH out</sub> Mode = OFF	60	80		dB
INPUT STAGE						
R <sub>IN</sub>	Input Resistance		35	50	65	KΩ
V <sub>CL</sub>	Clipping Level	THD = 0.3%	2	2.5		V <sub>rms</sub>
C <sub>RANGE</sub>	Control Range			31.5		dB
A <sub>VMIN</sub>	Min. Attenuation		-1	0	1	dB
A <sub>VMAX</sub>	Max. Attenuation		31	31.5	32	dB
A <sub>STEP</sub>	Step Resolution			0.5	1	dB
BASS CONTROL						
G <sub>b</sub>	Control Range	Max. Boost/cut	±11.5	±14.0	±16.0	dB
B <sub>STEP</sub>	Step Resolution		1	2	3	dB
R <sub>B</sub>	Internal Feedback Resistance		32	44	56	KΩ
MIDDLE CONTROL						
G <sub>m</sub>	Control Range	Max. Boost/cut	±11.5	±14.0	±16.0	dB
M <sub>STEP</sub>	Step Resolution		1	2	3	dB
R <sub>M</sub>	Internal Feedback Resistance		17.5	25	32.5	KΩ
TREBLE CONTROL						
G <sub>t</sub>	Control Range	Max. Boost/cut	±13.0	±14.0	±15.0	dB
T <sub>STEP</sub>	Step Resolution		1	2	3	dB

**Table 4. Electrical Characteristics**

(refer to the test circuit  $T_{amb} = 25^{\circ}\text{C}$ ,  $V_S = 9\text{V}$ ,  $R_L = 10\text{K}\Omega$ ,  $V_{in} = 1V_{rms}$ ;  $R_G = 600\Omega$ , all controls flat ( $G = 0\text{dB}$ ), L+R CTRL = +4dB, MODE = OFF;  $f = 1\text{KHz}$  unless otherwise specified).

Symbol	Parameter	Test Condition	Min.	Typ.	Max.	Unit
CONTROL L+R						
C <sub>RANGE</sub>	Control Range		- 11		+4	dB
S <sub>STEP</sub>	Step Resolution		0.5	1	1.5	dB
SPEAKER & AUX ATTENUATORS						
C <sub>RANGE</sub>	Control Range			79		dB
S <sub>STEP</sub>	Step Resolution		-0.5	1	1.5	dB
E <sub>A</sub>	Attenuation set error	$A_v = 0$ to -20dB	-1.5	0	1.5	dB
		$A_v = -20$ to -79dB	-3	0	2	dB
V <sub>DC</sub>	DC Steps	adjacent att. steps	-3	0	3	mV
A <sub>MUTE</sub>	Output Mute Condition		+70	100		dB
R <sub>VEA</sub>	Input Impedance		21	30	39	K $\Omega$
AUDIO OUTPUTS						
N <sub>O(OFF)</sub>	Output Noise (OFF)	Output Mute, Flat BW = 20Hz to 20KHz		4 5		$\mu\text{V}_{rms}$ $\mu\text{V}_{rms}$
d	Distorsion	$A_v = 0$ ; $V_{in} = 1V_{rms}$		0.01	0.1	%
S <sub>C</sub>	Channel Separation		70	90		dB
V <sub>OCL</sub>	Clipping Level	$d = 0.3\%$	2	2.5		V <sub>rms</sub>
R <sub>OUT</sub>	Output Resistance		20	40	70	$\Omega$
V <sub>OUT</sub>	DC Voltage Level			3.8		V
MONITOR OUTPUTS						
d	Distorsion	$A_v = 0$ ; $V_{in} = 1V_{rms}$		0.01	0.1	%
S <sub>C</sub>	Channel Separation		70	90		dB
V <sub>OCL</sub>	Clipping Level	$d = 0.3\%$	2	2.5		V <sub>rms</sub>
R <sub>OUT</sub>	Output Resistance		20	50	70	$\Omega$
V <sub>OUT</sub>	DC Voltage Level			4.5		V
BUS INPUTS						
V <sub>IL</sub>	Input Low Voltage				1	V
V <sub>IH</sub>	Input High Voltage		3			V
I <sub>IN</sub>	Input Current		-5		+5	mA
V <sub>O</sub>	Output Voltage SDA Acknowledge	$I_O = 1.6\text{mA}$			0.4	V

**1.0 I<sup>2</sup>C BUS INTERFACE**

Data transmission from microprocessor to the TDA7429L and viceversa takes place through the 2 wires I<sup>2</sup>C BUS interface, consisting of the two lines SDA and SCL (pull-up resistors to positive supply voltage must be connected).

**1.1 Data Validity**

As shown in fig. 3, the data on the SDA line must be stable during the high period of the clock. The HIGH and LOW state of the data line can only change when the clock signal on the SCL line is LOW.

**1.2 Start and Stop Conditions**

As shown in fig.4 a start condition is a HIGH to LOW transition of the SDA line while SCL is HIGH. The stop condition is a LOW to HIGH transition of the SDA line while SCL is HIGH.

**1.3 Byte Format**

Every byte transferred on the SDA line must contain 8 bits. Each byte must be followed by an acknowledge bit. The MSB is transferred first.

**1.4 Acknowledge**

The master (mP) puts a resistive HIGH level on the SDA line during the acknowledge clock pulse (see fig. 5). The peripheral (audioprocessor) that acknowledges has to pull-down (LOW) the SDA line during this clock pulse.

The audioprocessor which has been addressed has to generate an acknowledge after the reception of each byte, otherwise the SDA line remains at the HIGH level during the ninth clock pulse time. In this case the master transmitter can generate the STOP information in order to abort the transfer.

**1.5 Transmission without Acknowledge**

Avoiding to detect the acknowledge of the audioprocessor, the μP can use a simpler transmission: simply it waits one clock without checking the slave acknowledging, and sends the new data. This approach of course is less protected from misworking.

**Figure 4. Data validity on the I<sup>2</sup>C bus**

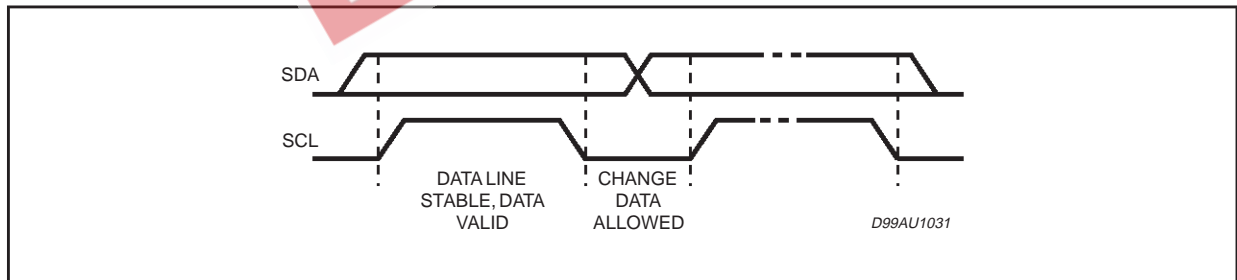

**Figure 5. Timing Diagram of I<sup>2</sup>C bus**

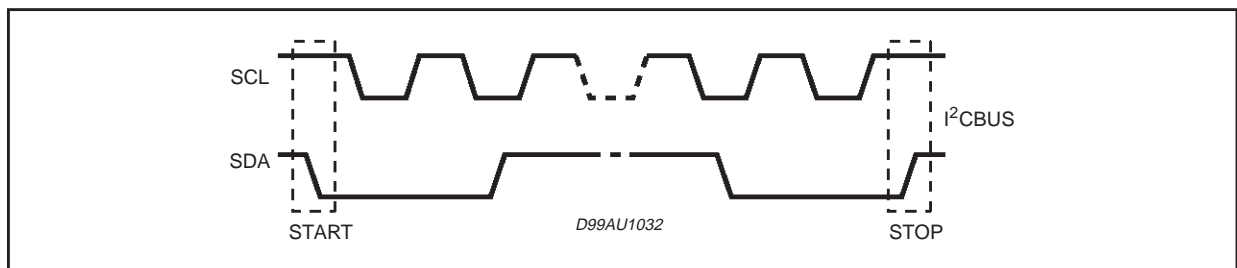
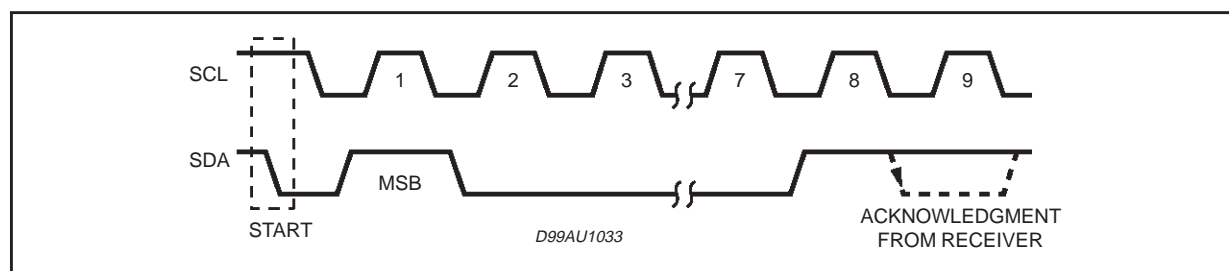

Figure 6. Acknowledge on the I<sup>2</sup>C bus

## 2.0 SOFTWARE SPECIFICATION

### 2.1 Interface Protocol

The interface protocol comprises:

- A start condition (S)
- A chip address byte, containing the TDA7429L address
- A subaddress bytes
- A sequence of data (N byte + acknowledge)
- A stop condition (P)



ACK = Acknowledge    S = Start    P = Stop    A = Address    B = Auto Increment

## 3.0 EXAMPLES

### 3.1 No Incremental Bus

The TDA7429L receives a start condition, the correct chip address, a subaddress with the MSB = 0 (no incremental bus), N-datas (all these datas concern the subaddress selected), a stop condition.

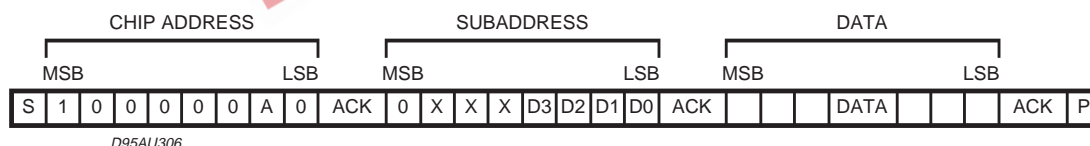

### 3.2 Incremental Bus

The TDA7429L receives a start condition, the correct chip address, a subaddress with the MSB = 1 (incremental bus): now it is in a loop condition with an autoincrease of the subaddress whereas SUBADDRESS from "1XXX1010" to "1XXX1111" of DATA are ignored. The DATA 1 concern the subaddress sent, and the DATA 2 concern the subaddress sent plus one in the loop etc, and at the end it receives the stop condition.

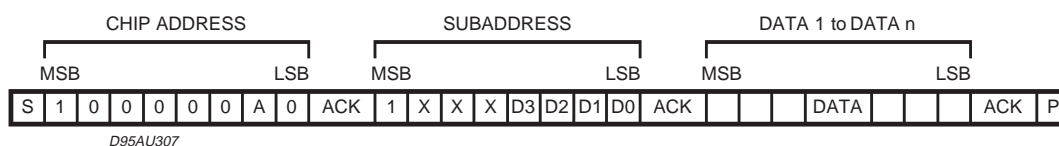

**Table 5. Function Selection**

The first byte (subaddress)

MSB							LSB	SUBADDRESS
D7	D6	D5	D4	D3	D2	D1	D0	
B <sup>1</sup>	X <sup>2</sup>	X	X	0	0	0	0	INPUT ATTENUATION
B	X	X	X	0	0	0	1	CONTROL OUT L+R & SUBWOOFER
B	X	X	X	0	0	1	0	NOT USED
B	X	X	X	0	0	1	1	BASS & NATURAL BASE
B	X	X	X	0	1	0	0	MIDDLE & TREBLE
B	X	X	X	0	1	0	1	SPEAKER ATTENUATION "L"
B	X	X	X	0	1	1	1	AUX ATTENUATION "L"
B	X	X	X	1	0	0	0	AUX ATTENUATION "R"
B	X	X	X	1	0	0	1	INPUT MULTIPLEXER, & AUX OUT

&lt;1&gt; B = 1 incremental bus; active

B = 0 no incremental bus;

&lt;2&gt; X = indifferent 0,1

**Table 6. Input Attenuation Selection**

MSB							LSB	INPUT ATTENUATION
D7	D6	D5	D4	D3	D2	D1	D0	
								<b>0.5 dB STEPS</b>
X					0	0	0	0
X					0	0	1	-0.5
X					0	1	0	-1
X					0	1	1	-1.5
X					1	0	0	-2
X					1	0	1	-2.5
X					1	1	0	-3
X					1	1	1	-3.5
								<b>4 dB STEPS</b>
X		0	0	0				0
X		0	0	1				-4
X		0	1	0				-8
X		0	1	1				-12
X		1	0	0				-16
X		1	0	1				-20
X		1	1	0				-24
X		1	1	1				-28
INPUT ATTENUATION = 0 ~ -31.5dB								
								<b>L+R OUTPUT SWITCH</b>
X	0							(L+R) OUTPUT PIN ACTIVE



Table 7. Out &amp; (L+R) &amp; Subwoofer Selection

MSB							LSB		
D7	D6	D5	D4	D3	D2	D1	D0	SUBWOOFER CONTROL	
X						0	0	SUBWOOFER ON	
X						0	1	NOT ALLOWED	
X						1	0	SUBWOOFER OFF	
X						1	1	NOT ALLOWED	
<b>OUT</b>									
X					0			VAR	
X					1			FIX	
<b>L+R CONTROL</b>									
X	0	0	0	0				+4	
X	0	0	0	1				+3	
X	0	0	1	0				+2	
X	0	0	1	1				+1	
X	0	1	0	0				0	
X	0	1	0	1				-1	
X	0	1	1	0				-2	
X	0	1	1	1				-3	
X	1	0	0	0				-4	
X	1	0	0	1				-5	
X	1	0	1	0				-6	
X	1	0	1	1				-7	
X	1	1	0	0				-8	
X	1	1	0	1				-9	
X	1	1	1	0				-10	
X	1	1	1	1				-11	

Table 8. Bass Selection

MSB							LSB		BASS
D7	D6	D5	D4	D3	D2	D1	D0	2 dB STEPS	
X	X	X	1	0	0	0	0	-14	
X	X	X	1	0	0	0	1	-12	
X	X	X	1	0	0	1	0	-10	
X	X	X	1	0	0	1	1	-8	
X	X	X	1	0	1	0	0	-6	
X	X	X	1	0	1	0	1	-4	
X	X	X	1	0	1	1	0	-2	
X	X	X	1	0	1	1	1	0	
X	X	X	1	1	1	1	1	0	
X	X	X	1	1	1	1	0	2	
X	X	X	1	1	1	0	1	4	
X	X	X	1	1	1	0	0	6	
X	X	X	1	1	0	1	1	8	
X	X	X	1	1	0	1	0	10	
X	X	X	1	1	0	0	1	12	
X	X	X	1	1	0	0	0	14	

Table 9. Speaker/Aux Att. R &amp; L Selection

MSB							LSB		SPEAKER/AUX ATT
D7	D6	D5	D4	D3	D2	D1	D0	1 dB STEPS	
X					0	0	0	0	
X					0	0	1	-1	
X					0	1	0	-2	
X					0	1	1	-3	
X					1	0	0	-4	
X					1	0	1	-5	
X					1	1	0	-6	
X					1	1	1	-7	
								<b>8 dB STEPS</b>	
X	0	0	0	0				0	
X	0	0	0	1				-8	
X	0	0	1	0				-16	
X	0	0	1	1				-24	
X	0	1	0	0				-32	
X	0	1	0	1				-40	
X	0	1	1	0				-48	
X	0	1	1	1				-56	
X	1	0	0	0				-64	
X	1	0	0	1				-72	
								<b>MUTE</b>	
X	1	0	1	X					
X	1	1	X	X					

Notes: 1. X = INDIFFERENT 0.1

2. SPEAKER/AUX ATTENUATION = 0dB to 79dB

Table 10. Middle &amp; Treble Selection

MSB								LSB	MIDDLE
D7	D6	D5	D4	D3	D2	D1	D0	2 dB STEPS	
				0	0	0	0	-14	
				0	0	0	1	-12	
				0	0	1	0	-10	
				0	0	1	1	-8	
				0	1	0	0	-6	
				0	1	0	1	-4	
				0	1	1	0	-2	
				0	1	1	1	0	
				1	1	1	1	0	
				1	1	1	0	2	
				1	1	0	1	4	
				1	1	0	0	6	
				1	0	1	1	8	
				1	0	1	0	10	
				1	0	0	1	12	
				1	0	0	0	14	
								<b>TREBLE</b>	
								<b>2 dB STEPS</b>	
0	0	0	0					-14	
0	0	0	1					-12	
0	0	1	0					-10	
0	0	1	1					-8	
0	1	0	0					-6	
0	1	0	1					-4	
0	1	1	0					-2	
0	1	1	1					0	
1	1	1	1					0	
1	1	1	0					2	
1	1	0	1					4	
1	1	0	0					6	
1	0	1	1					8	
1	0	1	0					10	
1	0	0	1					12	
1	0	0	0					14	

Table 11. Input/recout L &amp; R Selection

MSB							LSB		
D7	D6	D5	D4	D3	D2	D1	D0	INPUT MULTIPLEXER	
X					1	1	0	IN1	
X					0	0	0	IN2	
X					0	1	0	IN3	
								<b>AUX OUT "L"</b>	
X			0	0			0	VAR 1 (3BAND)	
X			0	1			0	NOT ALLOWED	
X			1	0			0	VAR 3 (REAR)	
X			1	1			0	FIX	
								<b>AUX OUT "R"</b>	
X	0	0					0	VAR 1 (3BAND)	
X	0	1					0	NOT ALLOWED	
X	1	0					0	VAR 3 (REAR)	
X	1	1					0	FIX	

Table 12. Power on reset

BASS & MIDDLE	2dB
TREBLE	0dB
SURROUND & OUT CONTROL + (L+R) CONTROL	OFF + FIX + MAX. ATTENUATION
SPEAKER/AUX ATTENUATION L & R	MUTE
INPUT ATTENUATION + (L+R) SWITCH	MAX. ATTENUATION + ON
NATURAL BASE	OFF
INPUT	IN1

Figure 7. Pin: TREBLE-L, TREBLE-R

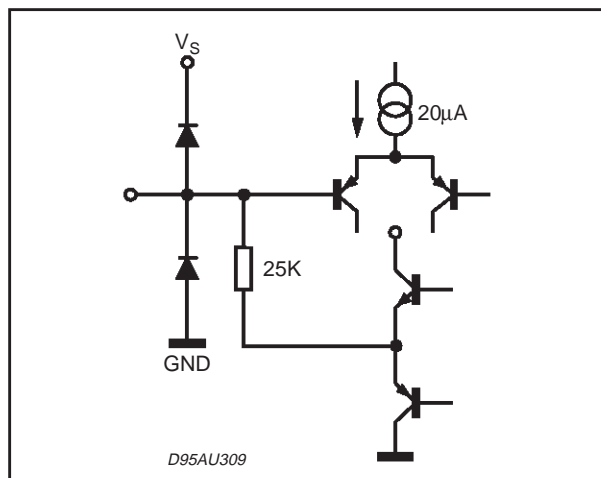

Figure 10. Pin: CREF

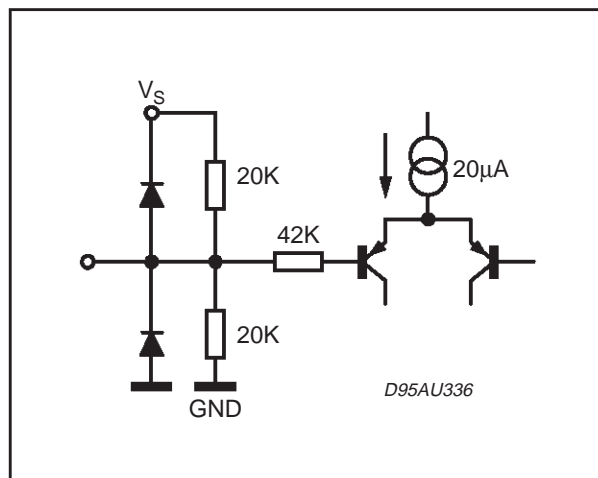

Figure 8. Pin: V<sub>OUT REF</sub>

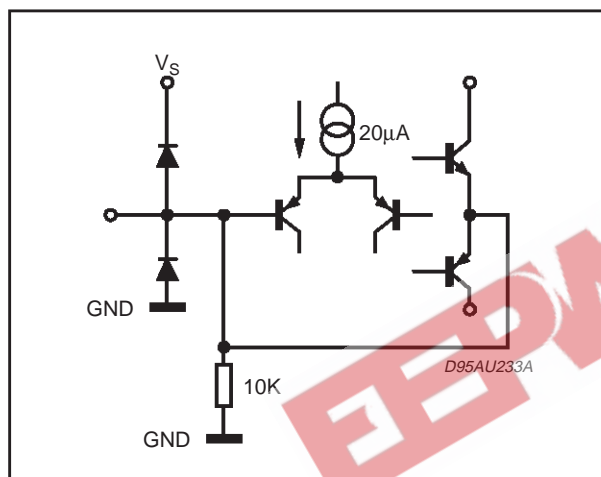

Figure 11. Pin: VAR-L, VAR-R

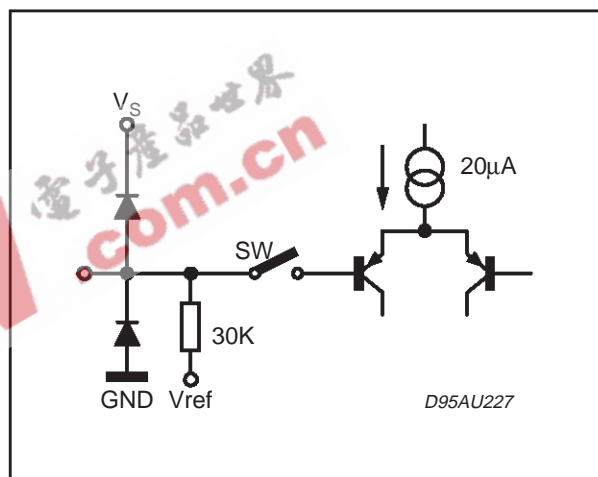

Figure 9. Pin: L-IN, R-IN, L-IN2, R-IN2, L-IN3, R-IN3, L-IN4, R-IN4

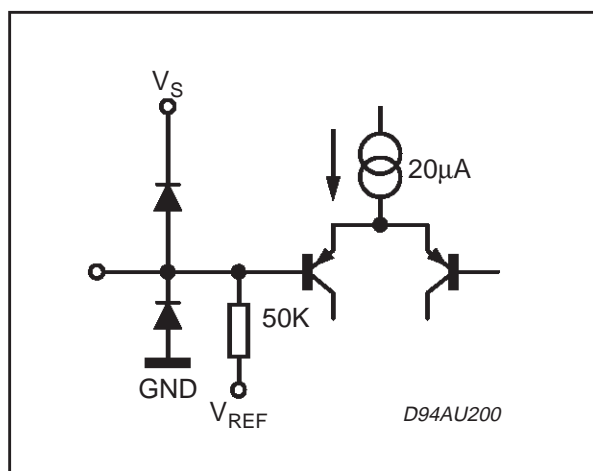

Figure 12. Pin: LP1, LP

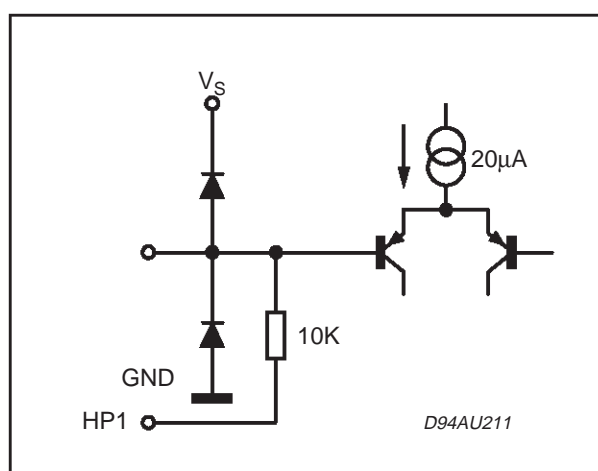

Figure 13. Pin: SCL, SDA

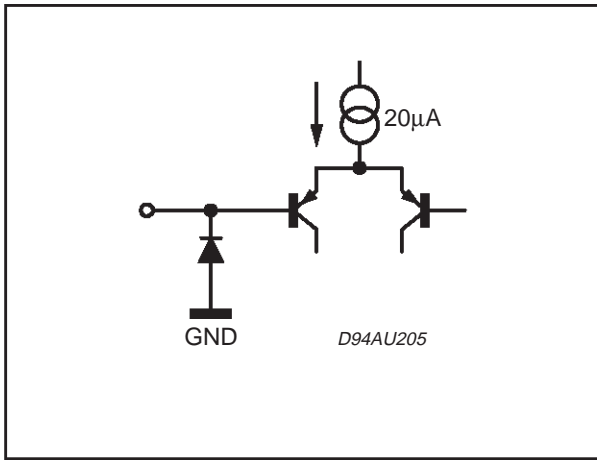

Figure 16. Pin: BASS-LI, BASS-RI, MIDDLE-LI, MIDDLE-R

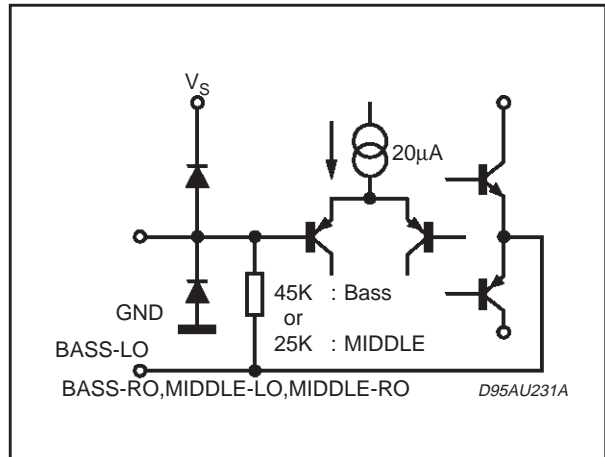

Figure 14. Pin: MONO INPUT

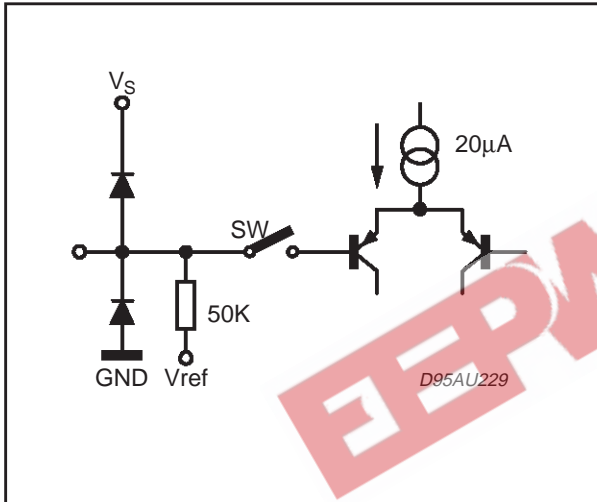

Figure 17. Pin: BASS-LO, BASS-RO, MIDDLE-LO, MIDDLE-RO

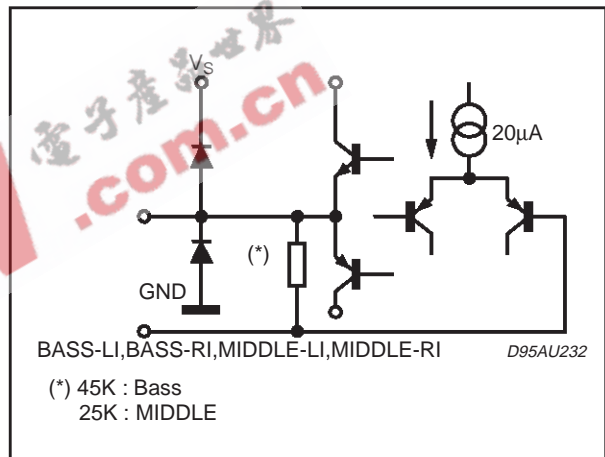
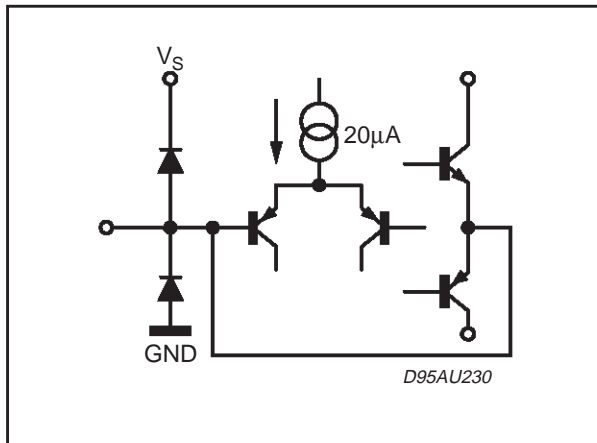
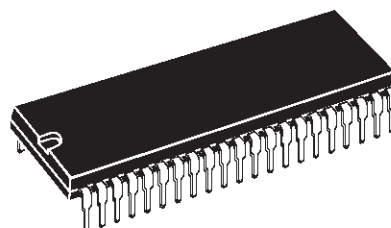

Figure 15. Pin: L-OUT, R-OUT, MONITOR-L, MONITOR-R, LTR OUTPUT, BASSO-L, BASSO-R, AUXOUT\_L, AUXOUT\_R



DIM.	mm			inch		
	MIN.	TYP.	MAX.	MIN.	TYP.	MAX.
A			5.08			0.20
A1	0.51			0.020		
A2	3.05	3.81	4.57	0.120	0.150	0.180
B	0.38	0.46	0.56	0.0149	0.0181	0.0220
B1	0.89	1.02	1.14	0.035	0.040	0.045
c	0.23	0.25	0.38	0.0090	0.0098	0.0150
D	36.58	36.83	37.08	1.440	1.450	1.460
E	15.24		16.00	0.60		0.629
E1	12.70	13.72	14.48	0.50	0.540	0.570
e		1.778			0.070	
e1		15.24			0.60	
e2			18.54			0.730
e3			1.52			0.060
L	2.54	3.30	3.56	0.10	0.130	0.140

## OUTLINE AND MECHANICAL DATA



SDIP42 (0.600")

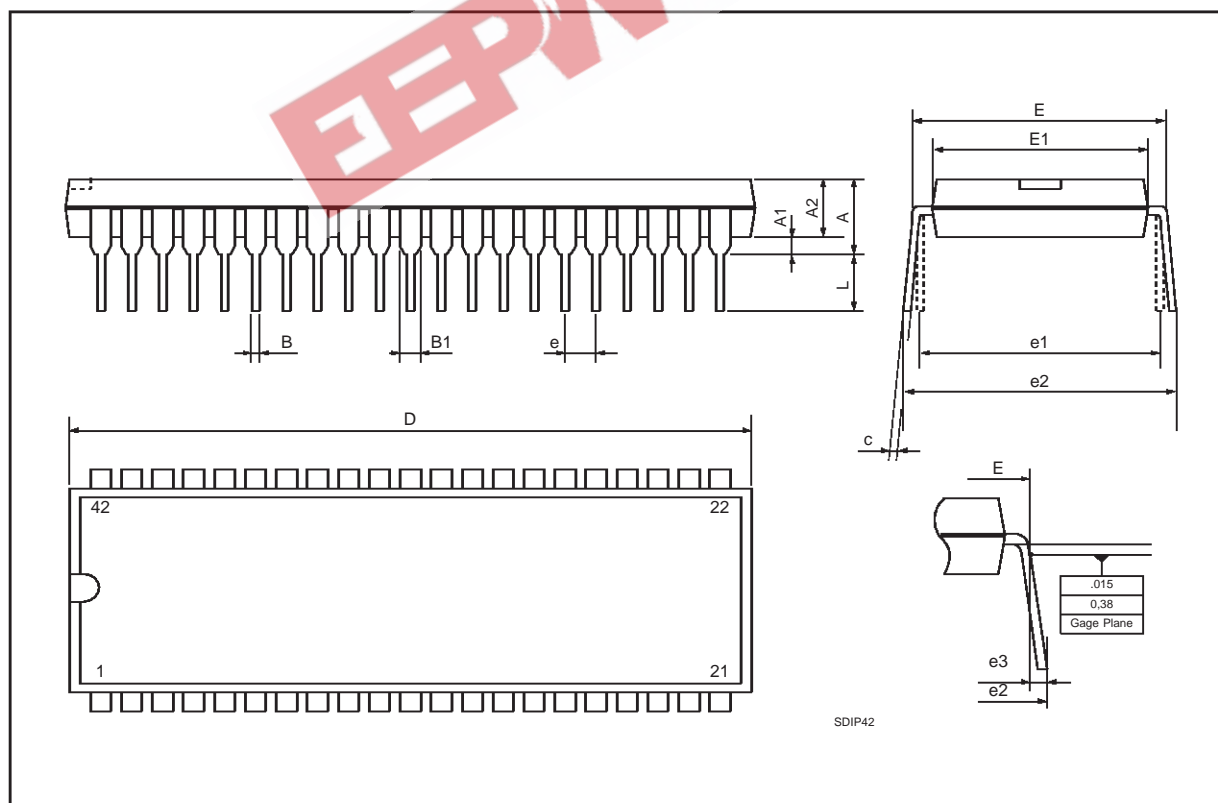

EEPW 电子产品世界  
.com.cn

Information furnished is believed to be accurate and reliable. However, STMicroelectronics assumes no responsibility for the consequences of use of such information nor for any infringement of patents or other rights of third parties which may result from its use. No license is granted by implication or otherwise under any patent or patent rights of STMicroelectronics. Specifications mentioned in this publication are subject to change without notice. This publication supersedes and replaces all information previously supplied. STMicroelectronics products are not authorized for use as critical components in life support devices or systems without express written approval of STMicroelectronics.

The ST logo is a registered trademark of STMicroelectronics  
© 2000 STMicroelectronics - All Rights Reserved

STMicroelectronics GROUP OF COMPANIES  
Australia - Brazil - China - Finland - France - Germany - Hong Kong - India - Italy - Japan - Malaysia - Malta - Morocco - Singapore - Spain  
- Sweden - Switzerland - United Kingdom - U.S.A.  
<http://www.st.com>