

# DATA SHEET

For a complete data sheet, please also download:

- The IC06 74HC/HCT/HCU/HCMOS Logic Family Specifications
- The IC06 74HC/HCT/HCU/HCMOS Logic Package Information
- The IC06 74HC/HCT/HCU/HCMOS Logic Package Outlines

EEPW 电子产品世界  
.com.cn

## 74HC/HCT4075 Triple 3-input OR gate

Product specification  
File under Integrated Circuits, IC06

December 1990

## Triple 3-input OR gate

## 74HC/HCT4075

## FEATURES

- Output capability: standard
- I<sub>CC</sub> category: SSI

## GENERAL DESCRIPTION

The 74HC/HCT4075 are high-speed Si-gate CMOS devices and are pin compatible with the "4075" of the "4000B" series. They are specified in compliance with JEDEC standard no. 7A.

The 74HC/HCT4075 provide the 3-input OR function.

## QUICK REFERENCE DATA

GND = 0 V; T<sub>amb</sub> = 25 °C; t<sub>r</sub> = t<sub>f</sub> = 6 ns

SYMBOL	PARAMETER	CONDITIONS	TYPICAL		UNIT
			HC	HCT	
t <sub>PHL</sub> / t <sub>PLH</sub>	propagation delay nA, nB, nC to nY	C <sub>L</sub> = 15 pF; V <sub>CC</sub> = 5 V	8	10	ns
C <sub>I</sub>	input capacitance		3.5	3.5	pF
C <sub>PD</sub>	power dissipation capacitance per gate	notes 1 and 2	28	32	pF

## Notes

1. C<sub>PD</sub> is used to determine the dynamic power dissipation (P<sub>D</sub> in μW):

$$P_D = C_{PD} \times V_{CC}^2 \times f_i + \sum (C_L \times V_{CC}^2 \times f_o) \text{ where:}$$

f<sub>i</sub> = input frequency in MHz

f<sub>o</sub> = output frequency in MHz

∑ (C<sub>L</sub> × V<sub>CC</sub><sup>2</sup> × f<sub>o</sub>) = sum of outputs

C<sub>L</sub> = output load capacitance in pF

V<sub>CC</sub> = supply voltage in V

2. For HC the condition is V<sub>I</sub> = GND to V<sub>CC</sub>  
For HCT the condition is V<sub>I</sub> = GND to V<sub>CC</sub> - 1.5 V

## ORDERING INFORMATION

See "74HC/HCT/HCU/HCMOS Logic Package Information".

Triple 3-input OR gate

74HC/HCT4075

PIN DESCRIPTION

PIN NO.	SYMBOL	NAME AND FUNCTION
3, 1, 11	1A to 3A	data inputs
4, 2, 12	1B to 3B	data inputs
5, 8, 13	1C to 3C	data inputs
6, 9, 10	1Y to 3Y	data outputs
7	GND	ground (0 V)
14	V <sub>CC</sub>	positive supply voltage

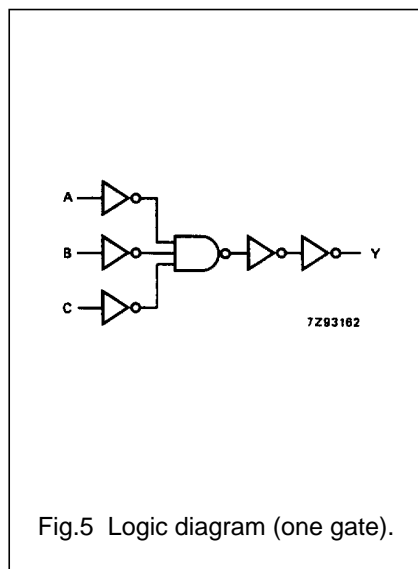
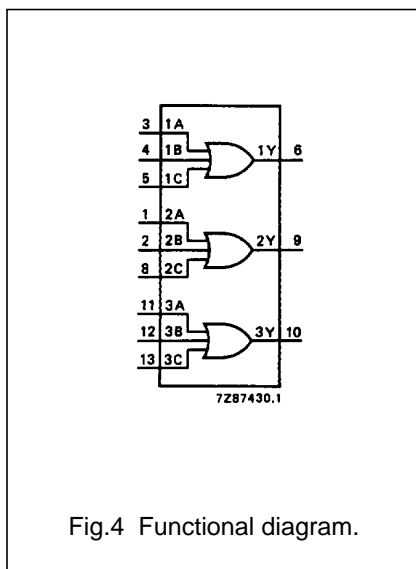
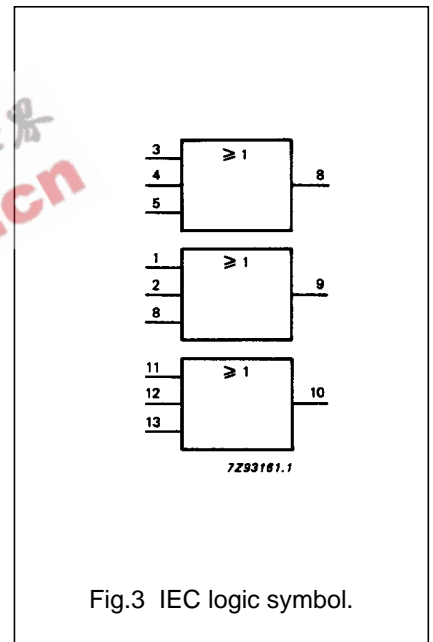
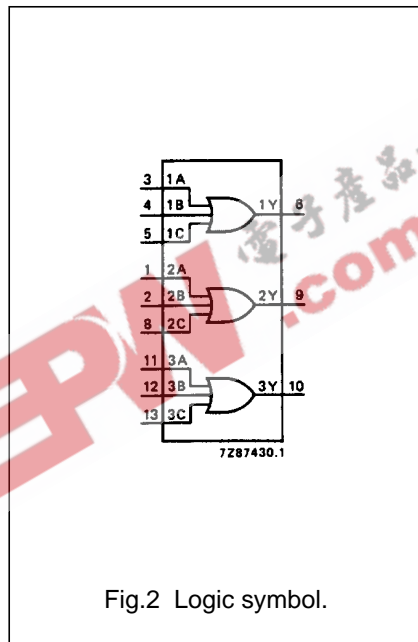
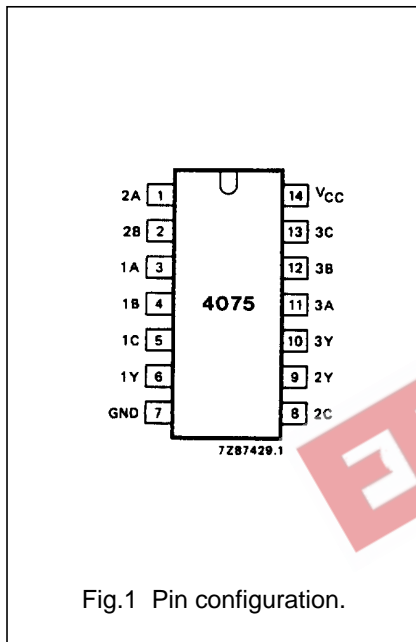

FUNCTION TABLE

INPUTS			OUTPUT
nA	nB	nC	nY
L	L	L	L
H	X	X	H
X	H	X	H
X	X	H	H

Notes

- H = HIGH voltage level  
L = LOW voltage level  
X = don't care

## Triple 3-input OR gate

## 74HC/HCT4075

**DC CHARACTERISTICS FOR 74HC**

For the DC characteristics see *"74HC/HCT/HCU/HCMOS Logic Family Specifications"*.

Output capability: standard

I<sub>CC</sub> category: SSI

**AC CHARACTERISTICS FOR 74HC**

GND = 0 V; t<sub>r</sub> = t<sub>f</sub> = 6 ns; C<sub>L</sub> = 50 pF

SYMBOL	PARAMETER	T <sub>amb</sub> (°C)						UNIT	TEST CONDITIONS		
		74HC							V <sub>CC</sub> (V)	WAVEFORMS	
		+25			-40 to +85		-40 to +125				
		min.	typ.	max.	min.	max.	min.				max.
t <sub>PHL</sub> / t <sub>PLH</sub>	propagation delay nA, nB, nC to nY		28	100		125		150	ns	2.0 4.5 6.0	Fig.6
			10	20		25		30			
			8	17		21		26			
t <sub>THL</sub> / t <sub>TLH</sub>	output transition time		19	75		95		110	ns	2.0 4.5 6.0	Fig.6
			7	15		19		22			
			6	13		16		19			

Triple 3-input OR gate

74HC/HCT4075

**DC CHARACTERISTICS FOR 74HCT**

For the DC characteristics see *"74HC/HCT/HCU/HCMOS Logic Family Specifications"*.

Output capability: standard

I<sub>CC</sub> category: SSI

**Note to HCT types**

The value of additional quiescent supply current ( $\Delta I_{CC}$ ) for a unit load of 1 is given in the family specifications. To determine  $\Delta I_{CC}$  per input, multiply this value by the unit load coefficient shown in the table below.

INPUT	UNIT LOAD COEFFICIENT
nA, nB, nC	1.50

**AC CHARACTERISTICS FOR 74HCT**

GND = 0 V; t<sub>r</sub> = t<sub>f</sub> = 6 ns; C<sub>L</sub> = 50 pF

SYMBOL	PARAMETER	T <sub>amb</sub> (°C)						UNIT	TEST CONDITIONS	
		74HCT							V <sub>CC</sub> (V)	WAVEFORMS
		+25			-40 to +85		-40 to +125			
min.	typ.	max.	min.	max.	min.	max.				
t <sub>PHL</sub> / t <sub>PLH</sub>	propagation delay nA, nB, nC to nY	12	24		30		36	ns	4.5	Fig.6
t <sub>THL</sub> / t <sub>TLH</sub>	output transition time	7	15		19		22	ns	4.5	Fig.6

**AC WAVEFORMS**

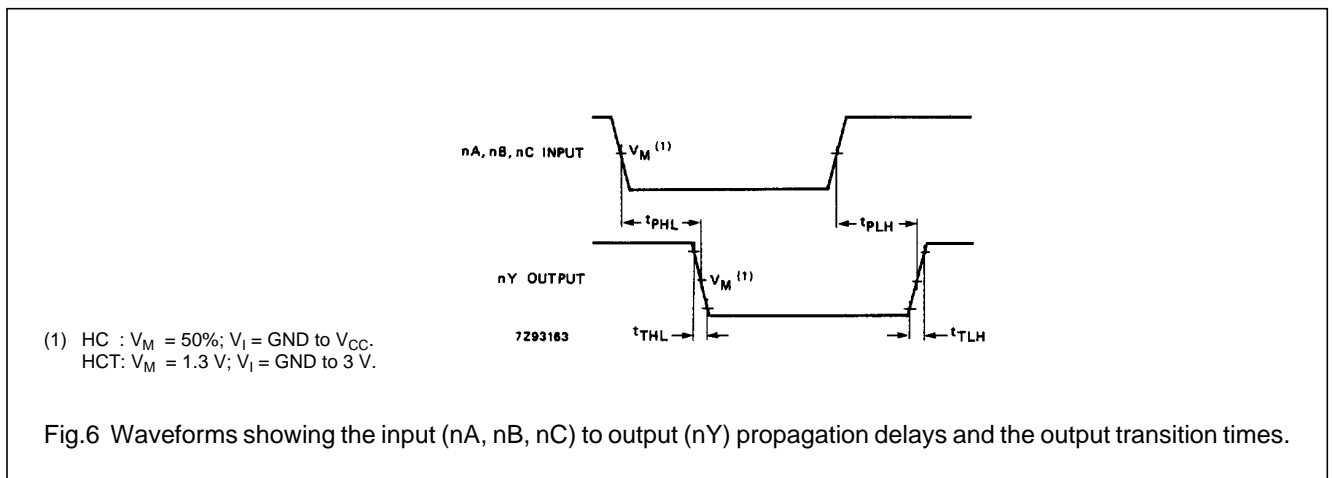

**PACKAGE OUTLINES**

See *"74HC/HCT/HCU/HCMOS Logic Package Outlines"*.