

74HC243

Quad bus transceiver; 3-state

Rev. 03 — 12 November 2004

Product data sheet

1. General description

The 74HC243 is a high-speed Si-gate CMOS device and is pin compatible with low power Schottky TTL (LSTTL). The 74HC243 is specified in compliance with JEDEC standard no. 7A.

The 74HC243 is a quad bus transceiver featuring non-inverting 3-state bus compatible outputs in both send and receive directions. The 74HC243 is designed for 4-line asynchronous 2-way data communications between data buses.

The output enable inputs ($\overline{OE}A$ and OEB) can be used to isolate the buses.

The 74HC243 is similar to the 74HC242 but has non-inverting (true) outputs.

2. Features

- Non-inverting 3-state outputs
- 2-way asynchronous data bus communication
- Low-power dissipation
- Complies with JEDEC standard no. 7A
- ESD protection:
 - ◆ HBM EIA/JESD22-A114-B exceeds 2000 V
 - ◆ MM EIA/JESD22-A115-A exceeds 200 V.
- Multiple package options
- Specified from $-40\text{ }^{\circ}\text{C}$ to $+80\text{ }^{\circ}\text{C}$ and from $-40\text{ }^{\circ}\text{C}$ to $+125\text{ }^{\circ}\text{C}$.

PHILIPS

3. Quick reference data

Table 1: Quick reference data

$GND = 0\text{ V}$; $T_{amb} = 25\text{ °C}$; $t_r = t_f = 6\text{ ns}$.

Symbol	Parameter	Conditions	Min	Typ	Max	Unit
t_{PHL} , t_{PLH}	propagation delay An to Bn; Bn to An	$C_L = 15\text{ pF}$; $V_{CC} = 5\text{ V}$	-	6	-	ns
C_I	input capacitance		-	3.5	-	pF
$C_{I/O}$	input/output capacitance		-	10	-	pF
C_{PD}	power dissipation capacitance per transceiver	$V_I = GND$ to V_{CC}	[1]	26	-	pF

[1] C_{PD} is used to determine the dynamic power dissipation (P_D in μW).

$$P_D = C_{PD} \times V_{CC}^2 \times f_i \times N + \sum(C_L \times V_{CC}^2 \times f_o) \text{ where:}$$

f_i = input frequency in MHz;

f_o = output frequency in MHz;

C_L = output load capacitance in pF;

V_{CC} = supply voltage in V;

N = number of inputs switching;

$\sum(C_L \times V_{CC}^2 \times f_o)$ = sum of outputs.

4. Ordering information

Table 2: Ordering information

Type number	Package			
	Temperature range	Name	Description	Version
74HC243N	-40 °C to +125 °C	DIP14	plastic dual in-line package; 14 leads (300 mil)	SOT27-1
74HC243D	-40 °C to +125 °C	SO14	plastic small outline package; 14 leads; body width 3.9 mm	SOT108-1
74HC243DB	-40 °C to +125 °C	SSOP14	plastic shrink small outline package; 14 leads; body width 5.3 mm	SOT337-1

5. Functional diagram

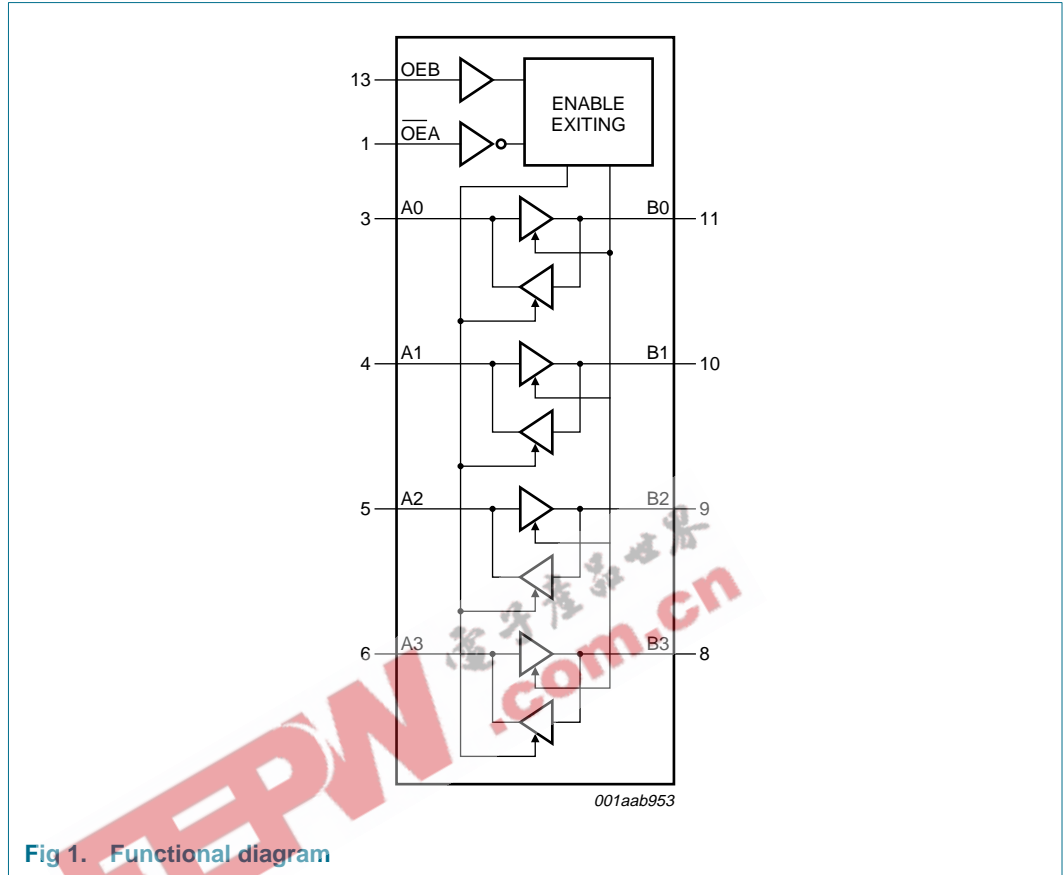

Fig 1. Functional diagram

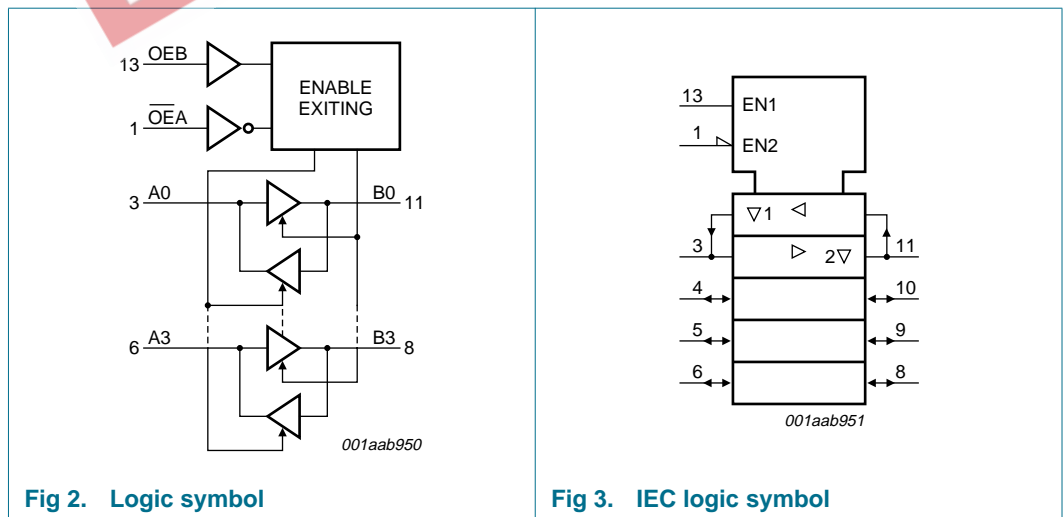
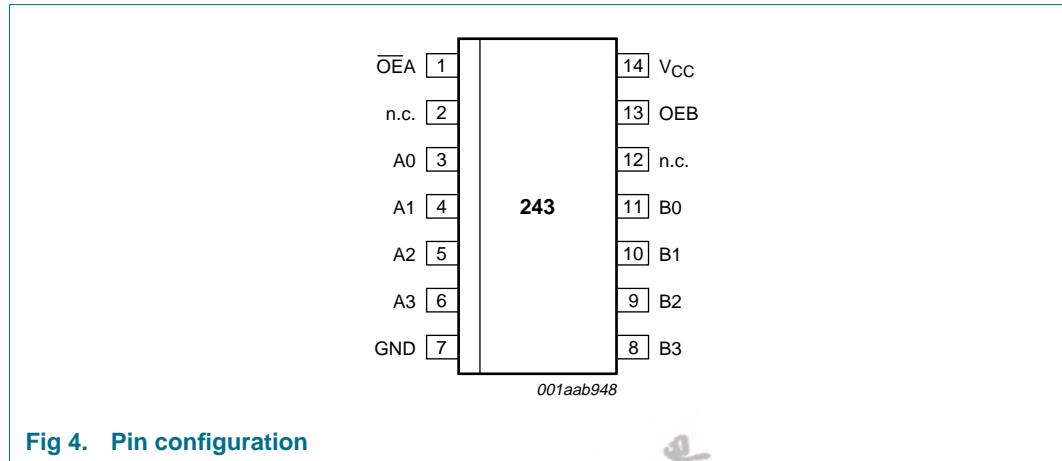

Fig 2. Logic symbol

Fig 3. IEC logic symbol

6. Pinning information

6.1 Pinning



6.2 Pin description

Table 3: Pin description

Symbol	Pin	Description
OĒA	1	output enable input (active LOW)
n.c.	2	not connected
A0	3	data input or output
A1	4	data input or output
A2	5	data input or output
A3	6	data input or output
GND	7	ground (0 V)
B3	8	data output or input
B2	9	data output or input
B1	10	data output or input
B0	11	data output or input
n.c.	12	not connected
OEB	13	output enable input
V _{CC}	14	positive supply voltage

7. Functional description

7.1 Function table

Table 4: Function table ^[1]

Control		Input or output	
OEA	OEB	An	Bn
L	L	input	B = A
H	L	Z	Z
L	H	Z	Z
H	H	A = B	input

[1] H = HIGH voltage level;
L = LOW voltage level;
Z = high-impedance OFF-state.

8. Limiting values

Table 5: Limiting values

In accordance with the Absolute Maximum Rating System (IEC 60134). Voltages are referenced to GND (ground = 0 V).

Symbol	Parameter	Conditions	Min	Max	Unit
V_{CC}	supply voltage		-0.5	+7	V
I_{IK}	input diode current	$V_I < -0.5\text{ V}$ or $V_I > V_{CC} + 0.5\text{ V}$	-	± 20	mA
I_{OK}	output diode current	$V_O < -0.5\text{ V}$ or $V_O > V_{CC} + 0.5\text{ V}$	-	± 20	mA
I_O	output source or sink current	$V_O = -0.5\text{ V}$ to $V_{CC} + 0.5\text{ V}$	-	± 35	mA
I_{CC}, I_{GND}	V_{CC} or GND current		-	± 70	mA
T_{stg}	storage temperature		-65	+150	°C
P_{tot}	power dissipation				
	DIP14 package		^[1] -	750	mW
	SO14 and SSOP16 packages		^[2] -	500	mW

[1] Above 70 °C: P_{tot} derates linearly with 12 mW/K.

[2] Above 70 °C: P_{tot} derates linearly with 8 mW/K.

9. Recommended operating conditions

Table 6: Recommended operating conditions

Symbol	Parameter	Conditions	Min	Typ	Max	Unit
V_{CC}	supply voltage		2.0	5.0	6.0	V
V_I	input voltage		0	-	V_{CC}	V
V_O	output voltage		0	-	V_{CC}	V
t_r, t_f	input rise and fall times	$V_{CC} = 2.0\text{ V}$	-	-	1000	ns
		$V_{CC} = 4.5\text{ V}$	-	6.0	500	ns
		$V_{CC} = 6.0\text{ V}$	-	-	400	ns
T_{amb}	ambient temperature		-40	-	+125	°C

10. Static characteristics

Table 7: Static characteristics

At recommended operating conditions; voltages are referenced to GND (ground = 0 V).

Symbol	Parameter	Conditions	Min	Typ	Max	Unit
$T_{amb} = 25\text{ °C}$						
V_{IH}	HIGH-level input voltage	$V_{CC} = 2.0\text{ V}$	1.5	1.2	-	V
		$V_{CC} = 4.5\text{ V}$	3.15	2.4	-	V
		$V_{CC} = 6.0\text{ V}$	4.2	3.2	-	V
V_{IL}	LOW-level input voltage	$V_{CC} = 2.0\text{ V}$	-	0.8	0.5	V
		$V_{CC} = 4.5\text{ V}$	-	2.1	1.35	V
		$V_{CC} = 6.0\text{ V}$	-	2.8	1.8	V
V_{OH}	HIGH-level output voltage	$V_I = V_{IH}$ or V_{IL}				
		$I_O = -20\text{ }\mu\text{A}; V_{CC} = 2.0\text{ V}$	1.9	2.0	-	V
		$I_O = -20\text{ }\mu\text{A}; V_{CC} = 4.5\text{ V}$	4.4	4.5	-	V
		$I_O = -20\text{ }\mu\text{A}; V_{CC} = 6.0\text{ V}$	5.9	6.0	-	V
		$I_O = -6.0\text{ mA}; V_{CC} = 4.5\text{ V}$	3.98	4.32	-	V
		$I_O = -7.8\text{ mA}; V_{CC} = 6.0\text{ V}$	5.48	5.81	-	V
V_{OL}	LOW-level output voltage	$V_I = V_{IH}$ or V_{IL}				
		$I_O = 20\text{ }\mu\text{A}; V_{CC} = 2.0\text{ V}$	-	0	0.1	V
		$I_O = 20\text{ }\mu\text{A}; V_{CC} = 4.5\text{ V}$	-	0	0.1	V
		$I_O = 20\text{ }\mu\text{A}; V_{CC} = 6.0\text{ V}$	-	0	0.1	V
		$I_O = 6.0\text{ mA}; V_{CC} = 4.5\text{ V}$	-	0.15	0.26	V
		$I_O = 7.8\text{ mA}; V_{CC} = 6.0\text{ V}$	-	0.16	0.26	V
I_{LI}	input leakage current	$V_I = V_{CC}$ or GND; $V_{CC} = 6.0\text{ V}$	-	-	± 0.1	μA
I_{OZ}	3-state OFF-state current	$V_I = V_{IH}$ or $V_{IL}; V_{CC} = 6.0\text{ V}; V_O = V_{CC}$ or GND	-	-	± 0.5	μA
I_{CC}	quiescent supply current	$V_I = V_{CC}$ or GND; $I_O = 0\text{ A}; V_{CC} = 6.0\text{ V}$	-	-	8.0	μA
C_I	input capacitance		-	3.5	-	pF
$C_{I/O}$	input/output capacitance		-	10	-	pF

Table 7: Static characteristics ...continued

At recommended operating conditions; voltages are referenced to GND (ground = 0 V).

Symbol	Parameter	Conditions	Min	Typ	Max	Unit
$T_{amb} = -40\text{ °C to }+85\text{ °C}$						
V_{IH}	HIGH-level input voltage	$V_{CC} = 2.0\text{ V}$	1.5	-	-	V
		$V_{CC} = 4.5\text{ V}$	3.15	-	-	V
		$V_{CC} = 6.0\text{ V}$	4.2	-	-	V
V_{IL}	LOW-level input voltage	$V_{CC} = 2.0\text{ V}$	-	-	0.5	V
		$V_{CC} = 4.5\text{ V}$	-	-	1.35	V
		$V_{CC} = 6.0\text{ V}$	-	-	1.8	V
V_{OH}	HIGH-level output voltage	$V_I = V_{IH}$ or V_{IL}				
		$I_O = -20\text{ }\mu\text{A}$; $V_{CC} = 2.0\text{ V}$	1.9	-	-	V
		$I_O = -20\text{ }\mu\text{A}$; $V_{CC} = 4.5\text{ V}$	4.4	-	-	V
		$I_O = -20\text{ }\mu\text{A}$; $V_{CC} = 6.0\text{ V}$	5.9	-	-	V
		$I_O = -6.0\text{ mA}$; $V_{CC} = 4.5\text{ V}$	3.84	-	-	V
	$I_O = -7.8\text{ mA}$; $V_{CC} = 6.0\text{ V}$	5.34	-	-	V	
V_{OL}	LOW-level output voltage	$V_I = V_{IH}$ or V_{IL}				
		$I_O = 20\text{ }\mu\text{A}$; $V_{CC} = 2.0\text{ V}$	-	-	0.1	V
		$I_O = 20\text{ }\mu\text{A}$; $V_{CC} = 4.5\text{ V}$	-	-	0.1	V
		$I_O = 20\text{ }\mu\text{A}$; $V_{CC} = 6.0\text{ V}$	-	-	0.1	V
		$I_O = 6.0\text{ mA}$; $V_{CC} = 4.5\text{ V}$	-	-	0.33	V
	$I_O = 7.8\text{ mA}$; $V_{CC} = 6.0\text{ V}$	-	-	0.33	V	
I_{LI}	input leakage current	$V_I = V_{CC}$ or GND; $V_{CC} = 6.0\text{ V}$	-	-	± 1.0	μA
I_{OZ}	3-state OFF-state current	$V_I = V_{IH}$ or V_{IL} ; $V_{CC} = 6.0\text{ V}$; $V_O = V_{CC}$ or GND	-	-	± 5.0	μA
I_{CC}	quiescent supply current	$V_I = V_{CC}$ or GND; $I_O = 0\text{ A}$; $V_{CC} = 6.0\text{ V}$	-	-	80	μA
$T_{amb} = -40\text{ °C to }+125\text{ °C}$						
V_{IH}	HIGH-level input voltage	$V_{CC} = 2.0\text{ V}$	1.5	-	-	V
		$V_{CC} = 4.5\text{ V}$	3.15	-	-	V
		$V_{CC} = 6.0\text{ V}$	4.2	-	-	V
V_{IL}	LOW-level input voltage	$V_{CC} = 2.0\text{ V}$	-	-	0.5	V
		$V_{CC} = 4.5\text{ V}$	-	-	1.35	V
		$V_{CC} = 6.0\text{ V}$	-	-	1.8	V
V_{OH}	HIGH-level output voltage	$V_I = V_{IH}$ or V_{IL}				
		$I_O = -20\text{ }\mu\text{A}$; $V_{CC} = 2.0\text{ V}$	1.9	-	-	V
		$I_O = -20\text{ }\mu\text{A}$; $V_{CC} = 4.5\text{ V}$	4.4	-	-	V
		$I_O = -20\text{ }\mu\text{A}$; $V_{CC} = 6.0\text{ V}$	5.9	-	-	V
		$I_O = -6.0\text{ mA}$; $V_{CC} = 4.5\text{ V}$	3.7	-	-	V
	$I_O = -7.8\text{ mA}$; $V_{CC} = 6.0\text{ V}$	5.2	-	-	V	

Table 7: Static characteristics ...continued

At recommended operating conditions; voltages are referenced to GND (ground = 0 V).

Symbol	Parameter	Conditions	Min	Typ	Max	Unit
V _{OL}	LOW-level output voltage	V _I = V _{IH} or V _{IL}		-		
		I _O = 20 μA; V _{CC} = 2.0 V	-	-	0.1	V
		I _O = 20 μA; V _{CC} = 4.5 V	-	-	0.1	V
		I _O = 20 μA; V _{CC} = 6.0 V	-	-	0.1	V
		I _O = 6.0 mA; V _{CC} = 4.5 V	-	-	0.4	V
		I _O = 7.8 mA; V _{CC} = 6.0 V	-	-	0.4	V
I _{LI}	input leakage current	V _I = V _{CC} or GND; V _{CC} = 6.0 V	-	-	±1.0	μA
I _{OZ}	3-state OFF-state current	V _I = V _{IH} or V _{IL} ; V _{CC} = 6.0 V; V _O = V _{CC} or GND	-	-	±10.0	μA
I _{CC}	quiescent supply current	V _I = V _{CC} or GND; I _O = 0 A; V _{CC} = 6.0 V	-	-	160	μA

11. Dynamic characteristics

Table 8: Dynamic characteristicsGND = 0 V; t_r = t_f = 6 ns; C_L = 50 pF; R_L = 1000 Ω; see [Figure 8](#).

Symbol	Parameter	Conditions	Min	Typ	Max	Unit	
T_{amb} = 25 °C							
t _{PHL} , t _{PLH}	propagation delay An to Bn; Bn to An	see Figure 5					
		V _{CC} = 2.0 V	-	22	90	ns	
		V _{CC} = 4.5 V	-	8	18	ns	
		V _{CC} = 6.0 V	-	6	15	ns	
		V _{CC} = 5.0 V; C _L = 15 pF	-	6	-	ns	
t _{PZH} , t _{PZL}	3-state output enable time \overline{OEA} to An or Bn; OEB to An or Bn	see Figure 6 and 7					
		V _{CC} = 2.0 V	-	50	150	ns	
		V _{CC} = 4.5 V	-	18	30	ns	
		V _{CC} = 6.0 V	-	14	26	ns	
t _{PHZ} , t _{PLZ}	3-state output disable time \overline{OEA} to An or Bn; OEB to An or Bn	see Figure 6 and 7					
		V _{CC} = 2.0 V	-	61	165	ns	
		V _{CC} = 4.5 V	-	22	33	ns	
		V _{CC} = 6.0 V	-	18	28	ns	
t _{THL} , t _{TLH}	output transition time	see Figure 5					
		V _{CC} = 2.0 V	-	14	60	ns	
		V _{CC} = 4.5 V	-	5	12	ns	
		V _{CC} = 6.0 V	-	4	10	ns	
C _{PD}	power dissipation capacitance per transceiver	V _I = GND to V _{CC}	[1]	-	26	-	pF
T_{amb} = -40 °C to +85 °C							
t _{PHL} , t _{PLH}	propagation delay An to Bn; Bn to An	see Figure 5					
		V _{CC} = 2.0 V	-	-	115	ns	
		V _{CC} = 4.5 V	-	-	23	ns	
		V _{CC} = 6.0 V	-	-	20	ns	

Table 8: Dynamic characteristics ...continued

$GND = 0\text{ V}$; $t_r = t_f = 6\text{ ns}$; $C_L = 50\text{ pF}$; $R_L = 1000\ \Omega$; see [Figure 8](#).

Symbol	Parameter	Conditions	Min	Typ	Max	Unit
t_{PZH} , t_{PZL}	3-state output enable time \overline{OEA} to An or Bn; OEB to An or Bn	see Figure 6 and 7				
		$V_{CC} = 2.0\text{ V}$	-	-	190	ns
		$V_{CC} = 4.5\text{ V}$	-	-	38	ns
		$V_{CC} = 6.0\text{ V}$	-	-	33	ns
t_{PHZ} , t_{PLZ}	3-state output disable time \overline{OEA} to An or Bn; OEB to An or Bn	see Figure 6 and 7				
		$V_{CC} = 2.0\text{ V}$	-	-	205	ns
		$V_{CC} = 4.5\text{ V}$	-	-	41	ns
		$V_{CC} = 6.0\text{ V}$	-	-	35	ns
t_{THL} , t_{TLH}	output transition time	see Figure 5				
		$V_{CC} = 2.0\text{ V}$	-	-	75	ns
		$V_{CC} = 4.5\text{ V}$	-	-	15	ns
		$V_{CC} = 6.0\text{ V}$	-	-	13	ns
$T_{amb} = -40\text{ }^\circ\text{C to }+125\text{ }^\circ\text{C}$						
t_{PHL} , t_{PLH}	propagation delay An to Bn; Bn to An	see Figure 5				
		$V_{CC} = 2.0\text{ V}$	-	-	135	ns
		$V_{CC} = 4.5\text{ V}$	-	-	27	ns
		$V_{CC} = 6.0\text{ V}$	-	-	23	ns
t_{PZH} , t_{PZL}	3-state output enable time \overline{OEA} to An or Bn; OEB to An or Bn	see Figure 6 and 7				
		$V_{CC} = 2.0\text{ V}$	-	-	225	ns
		$V_{CC} = 4.5\text{ V}$	-	-	45	ns
		$V_{CC} = 6.0\text{ V}$	-	-	38	ns
t_{PHZ} , t_{PLZ}	3-state output disable time \overline{OEA} to An or Bn; OEB to An or Bn	see Figure 6 and 7				
		$V_{CC} = 2.0\text{ V}$	-	-	250	ns
		$V_{CC} = 4.5\text{ V}$	-	-	50	ns
		$V_{CC} = 6.0\text{ V}$	-	-	43	ns
t_{THL} , t_{TLH}	output transition time	see Figure 5				
		$V_{CC} = 2.0\text{ V}$	-	-	90	ns
		$V_{CC} = 4.5\text{ V}$	-	-	18	ns
		$V_{CC} = 6.0\text{ V}$	-	-	15	ns

[1] C_{PD} is used to determine the dynamic power dissipation (P_D in μW).

$$P_D = C_{PD} \times V_{CC}^2 \times f_i \times N + \sum(C_L \times V_{CC}^2 \times f_o) \text{ where:}$$

f_i = input frequency in MHz;

f_o = output frequency in MHz;

C_L = output load capacitance in pF;

V_{CC} = supply voltage in V;

N = number of inputs switching;

$\sum(C_L \times V_{CC}^2 \times f_o)$ = sum of outputs.

12. Waveforms

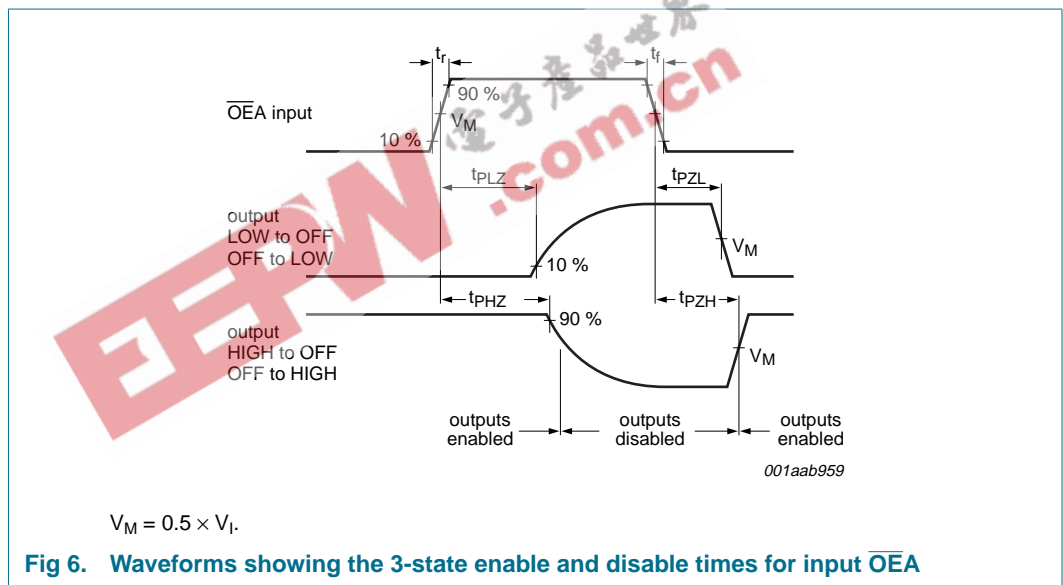
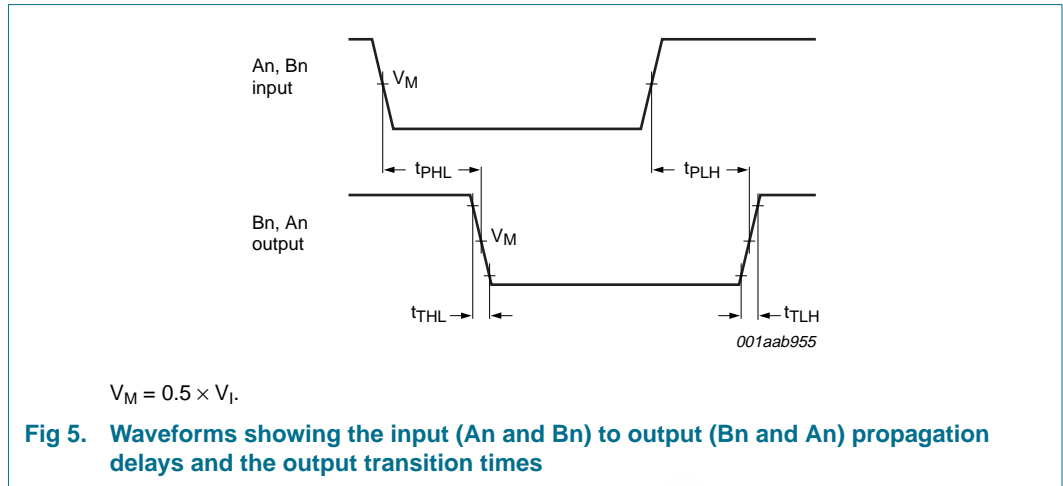

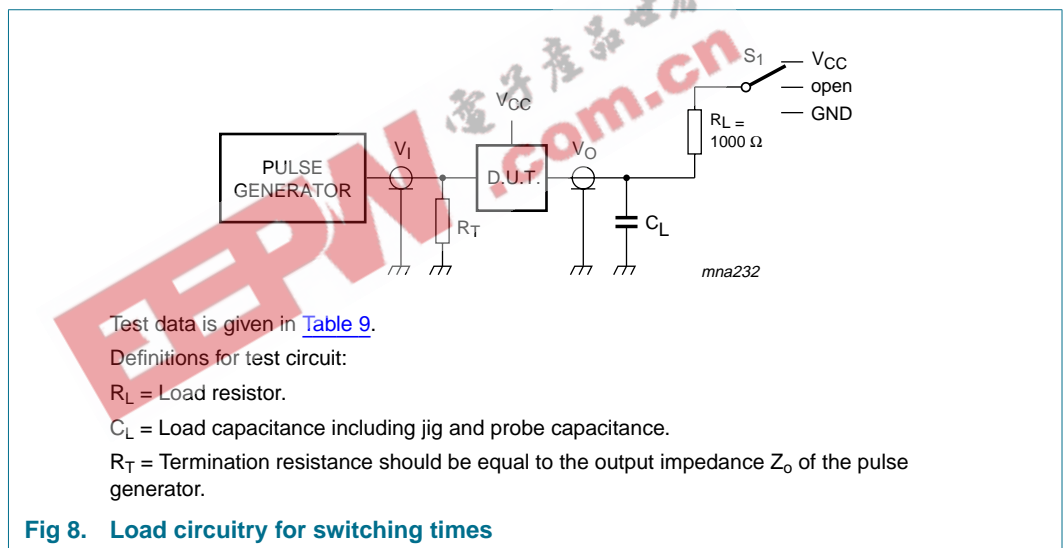
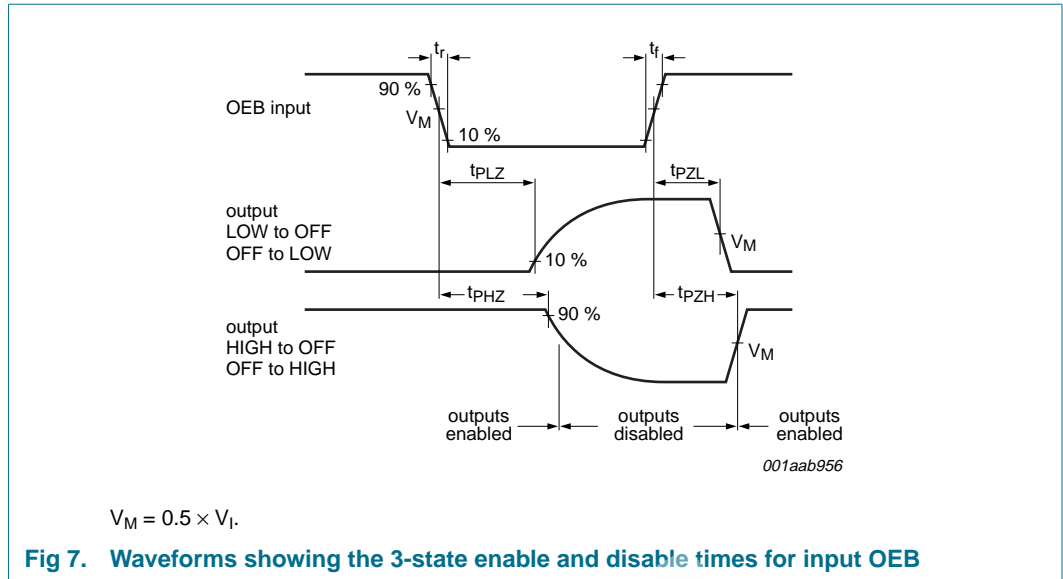

Table 9: Test data

Supply	Input	Load	S_1
V_{CC}	V_I	C_L R_L	t_{PZL}, t_{PLZ} t_{PZH}, t_{PHZ} t_{PHL}, t_{PLH}
2.0 V	V_{CC}	50 pF 1 kΩ	V_{CC} GND open
4.5 V	V_{CC}	50 pF 1 kΩ	V_{CC} GND open
6.0 V	V_{CC}	50 pF 1 kΩ	V_{CC} GND open
5.0 V	V_{CC}	15 pF 1 kΩ	V_{CC} GND open

13. Package outline

DIP14: plastic dual in-line package; 14 leads (300 mil)

SOT27-1

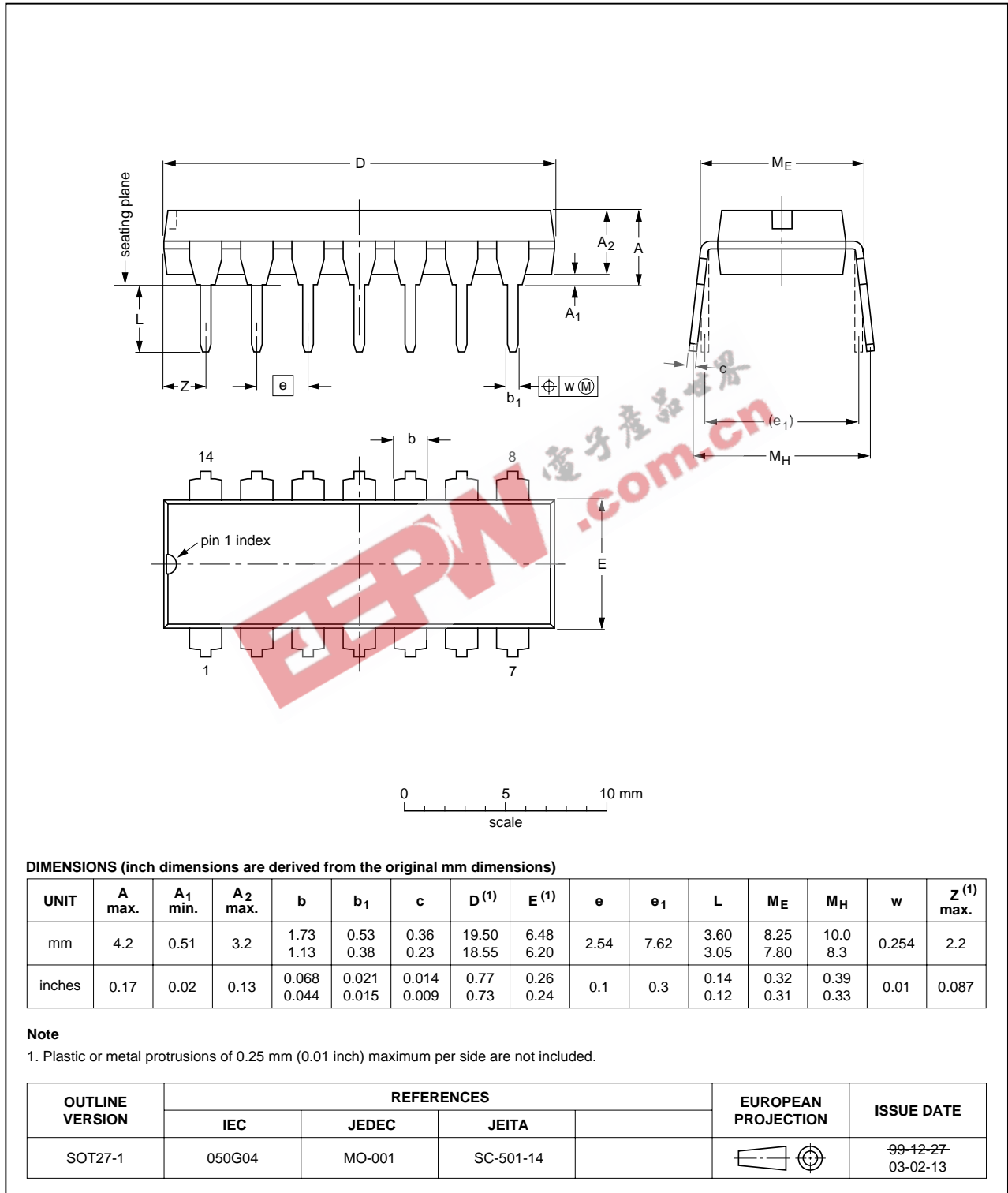

Fig 9. Package outline SOT27-1 (DIP14)

SO14: plastic small outline package; 14 leads; body width 3.9 mm

SOT108-1

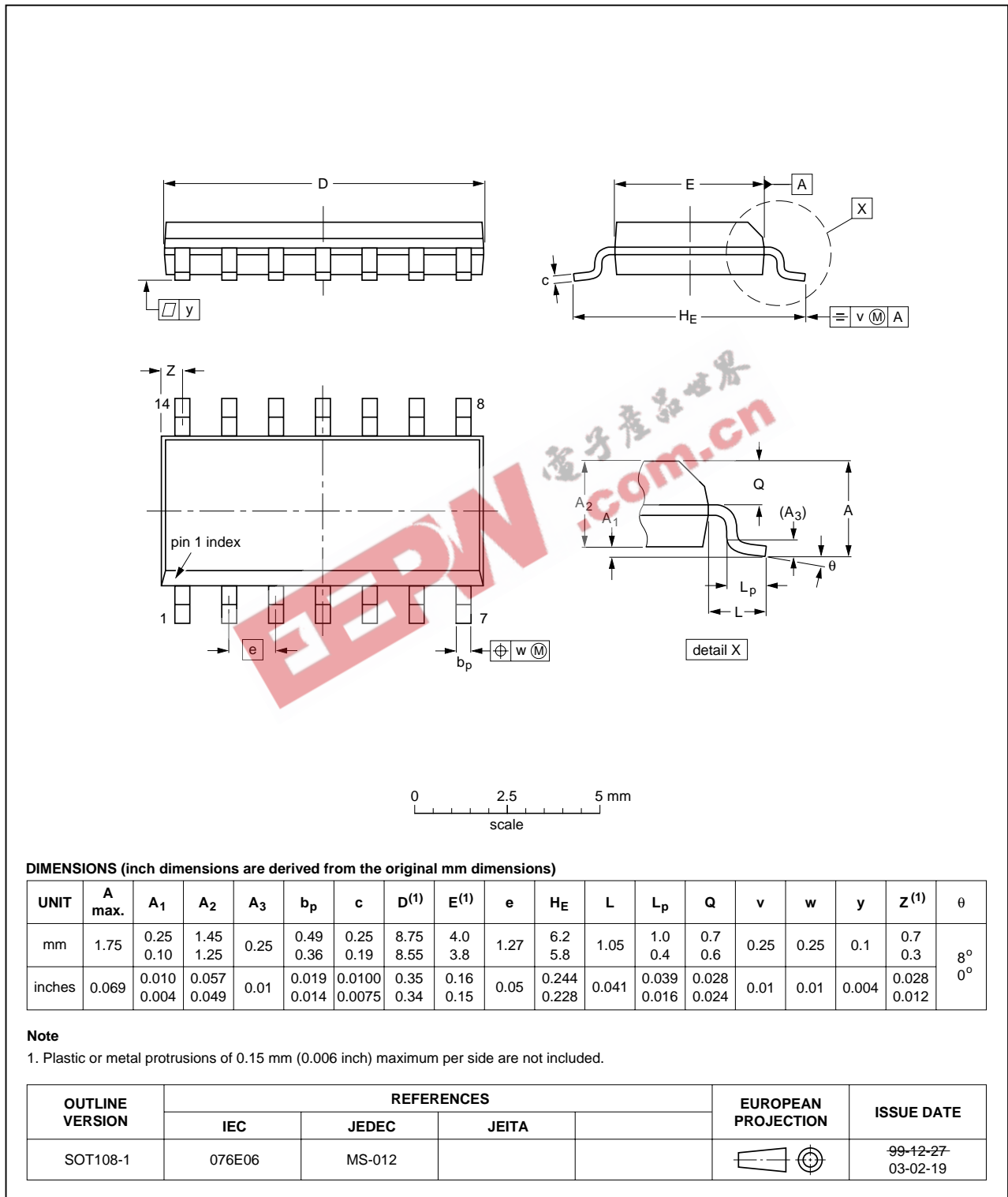

Fig 10. Package outline SOT108-1 (SO14)

SSOP14: plastic shrink small outline package; 14 leads; body width 5.3 mm

SOT337-1

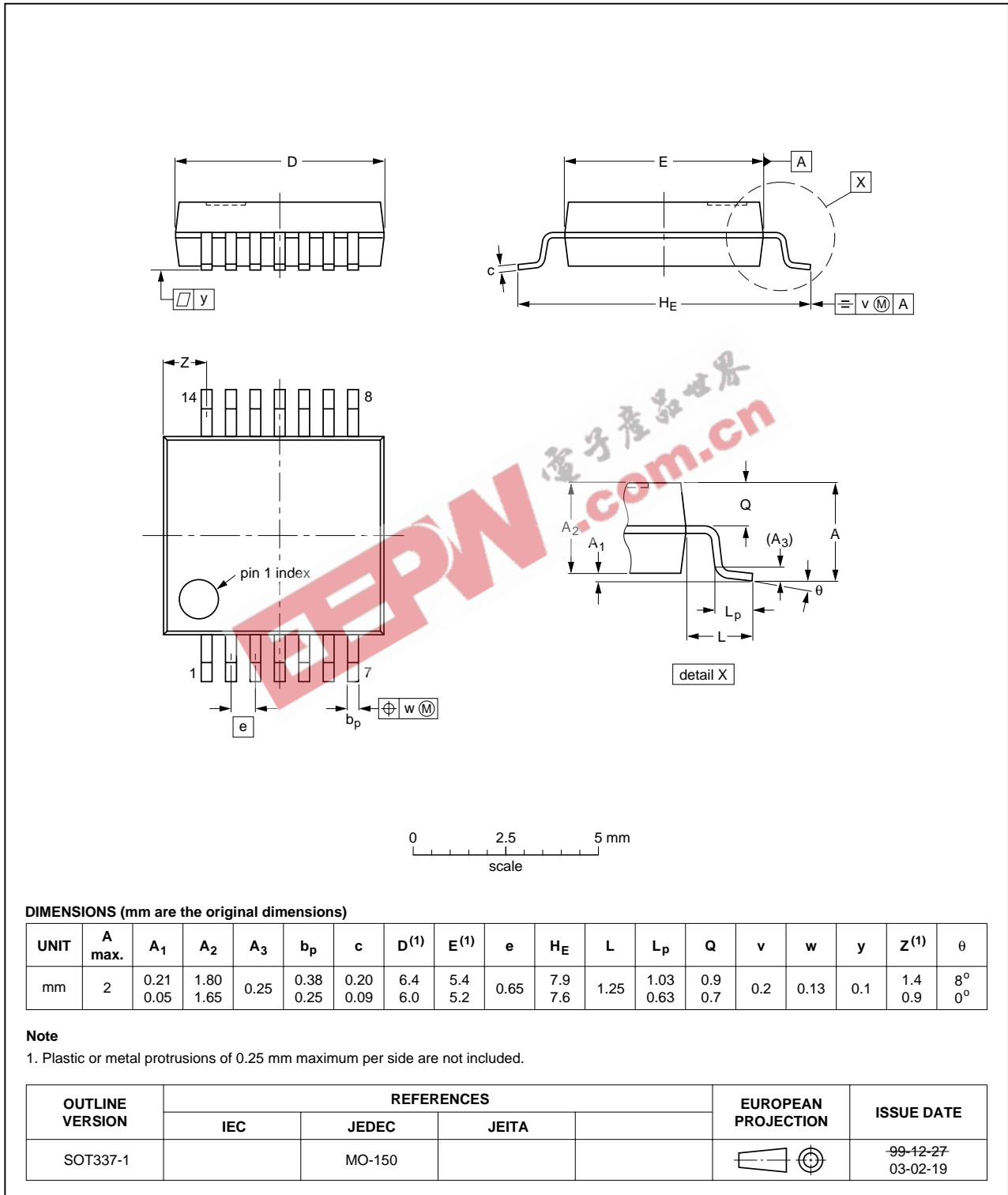

Fig 11. Package outline SOT337-1 (SSOP14)

14. Revision history

Table 10: Revision history

Document ID	Release date	Data sheet status	Change notice	Doc. number	Supersedes
74HC243_3	20041112	Product data sheet	-	9397 750 13808	74HC_HCT243_CNV_2
Modifications:					
					<ul style="list-style-type: none">• The format of this data sheet has been redesigned to comply with the current presentation and information standard of Philips Semiconductors.• Removed type number 74HCT243.• Inserted family specification.
74HC_HCT243_CNV_2	19970828	Product specification	-	-	74HC_HCT243_1
74HC_HCT243_1	19901201	Product specification	-	-	-

EEPW 电子产品世界
.com.cn

15. Data sheet status

Level	Data sheet status ^[1]	Product status ^[2] ^[3]	Definition
I	Objective data	Development	This data sheet contains data from the objective specification for product development. Philips Semiconductors reserves the right to change the specification in any manner without notice.
II	Preliminary data	Qualification	This data sheet contains data from the preliminary specification. Supplementary data will be published at a later date. Philips Semiconductors reserves the right to change the specification without notice, in order to improve the design and supply the best possible product.
III	Product data	Production	This data sheet contains data from the product specification. Philips Semiconductors reserves the right to make changes at any time in order to improve the design, manufacturing and supply. Relevant changes will be communicated via a Customer Product/Process Change Notification (CPCN).

[1] Please consult the most recently issued data sheet before initiating or completing a design.

[2] The product status of the device(s) described in this data sheet may have changed since this data sheet was published. The latest information is available on the Internet at URL <http://www.semiconductors.philips.com>.

[3] For data sheets describing multiple type numbers, the highest-level product status determines the data sheet status.

16. Definitions

Short-form specification — The data in a short-form specification is extracted from a full data sheet with the same type number and title. For detailed information see the relevant data sheet or data handbook.

Limiting values definition — Limiting values given are in accordance with the Absolute Maximum Rating System (IEC 60134). Stress above one or more of the limiting values may cause permanent damage to the device. These are stress ratings only and operation of the device at these or at any other conditions above those given in the Characteristics sections of the specification is not implied. Exposure to limiting values for extended periods may affect device reliability.

Application information — Applications that are described herein for any of these products are for illustrative purposes only. Philips Semiconductors make no representation or warranty that such applications will be suitable for the specified use without further testing or modification.

17. Disclaimers

Life support — These products are not designed for use in life support appliances, devices, or systems where malfunction of these products can reasonably be expected to result in personal injury. Philips Semiconductors customers using or selling these products for use in such applications do so at their own risk and agree to fully indemnify Philips Semiconductors for any damages resulting from such application.

Right to make changes — Philips Semiconductors reserves the right to make changes in the products - including circuits, standard cells, and/or software - described or contained herein in order to improve design and/or performance. When the product is in full production (status 'Production'), relevant changes will be communicated via a Customer Product/Process Change Notification (CPCN). Philips Semiconductors assumes no responsibility or liability for the use of any of these products, conveys no license or title under any patent, copyright, or mask work right to these products, and makes no representations or warranties that these products are free from patent, copyright, or mask work right infringement, unless otherwise specified.

18. Contact information

For additional information, please visit: <http://www.semiconductors.philips.com>

For sales office addresses, send an email to: sales.addresses@www.semiconductors.philips.com

19. Contents

1	General description	1
2	Features	1
3	Quick reference data	2
4	Ordering information	2
5	Functional diagram	3
6	Pinning information	4
6.1	Pinning	4
6.2	Pin description	4
7	Functional description	5
7.1	Function table	5
8	Limiting values	5
9	Recommended operating conditions	6
10	Static characteristics	6
11	Dynamic characteristics	8
12	Waveforms	10
13	Package outline	12
14	Revision history	15
15	Data sheet status	16
16	Definitions	16
17	Disclaimers	16
18	Contact information	16

EEPW.com.cn 电子产品世界



© Koninklijke Philips Electronics N.V. 2004

All rights are reserved. Reproduction in whole or in part is prohibited without the prior written consent of the copyright owner. The information presented in this document does not form part of any quotation or contract, is believed to be accurate and reliable and may be changed without notice. No liability will be accepted by the publisher for any consequence of its use. Publication thereof does not convey nor imply any license under patent- or other industrial or intellectual property rights.

Date of release: 12 November 2004
Document number: 9397 750 13808

Published in The Netherlands