

DATA SHEET

EEPW 电子產品世界
.com.cn

74F2244

Octal buffer with 30Ω equivalent output termination (3-State)

Product specification

1994 Dec 5

IC15 Data Handbook

Philips Semiconductors



PHILIPS

Octal buffer with 30Ω equivalent output termination (3-State)

74F2244

FEATURES

- Octal bus interface
- 30Ω output termination ideal for driving DRAM
- 15mA source current
- SSOP Type II Package

DESCRIPTION

The 74F2244 is an octal buffer that is ideal for driving dynamic DRAM with matching impedance. The outputs are all capable of sinking 5mA and sourcing up to 15mA. The device features two output enables, $\overline{OE}a$ and $\overline{OE}b$, each controlling four of the 3-state outputs.

TYPE	TYPICAL PROPAGATION DELAY	TYPICAL SUPPLY CURRENT (TOTAL)
74F2244	4.0ns	30mA

ORDERING INFORMATION

DESCRIPTION	ORDER CODE	DRAWING NUMBER
	COMMERCIAL RANGE $V_{CC} = 5V \pm 10\%$, $T_{amb} = 0^\circ C$ to $+70^\circ C$	
20-pin plastic DIP	N74F2244N	SOT146-1
20-pin plastic SOL	N74F2244D	SOT163-1
20-pin plastic SSOP Type II	N74F2244DB	SOT339-1

INPUT AND OUTPUT LOADING AND FAN OUT TABLE

PINS	DESCRIPTION	74F (U.L.) HIGH/LOW	LOAD VALUE HIGH/LOW
Ian, Ibn	Data inputs	1.0/0.33	20μA/0.2mA
$\overline{OE}a$, $\overline{OE}b$	Output enable inputs (active low)	1.0/0.33	20μA/0.2mA
Yan, Ybn	Data outputs	750/8.33	15mA/5mA

NOTE: One (1.0) FAST unit load is defined as: 20μA in the high state and 0.6mA in the low state.

PIN CONFIGURATION

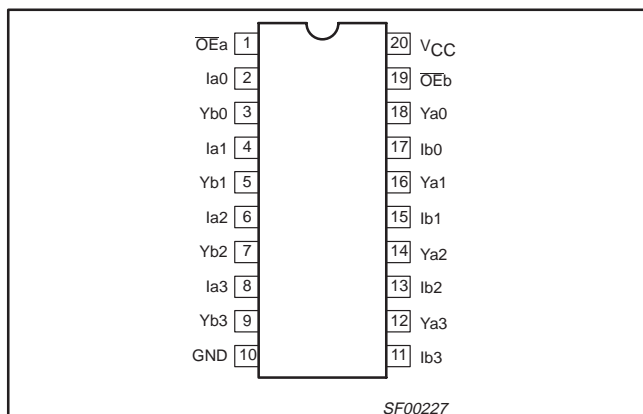

LOGIC SYMBOL

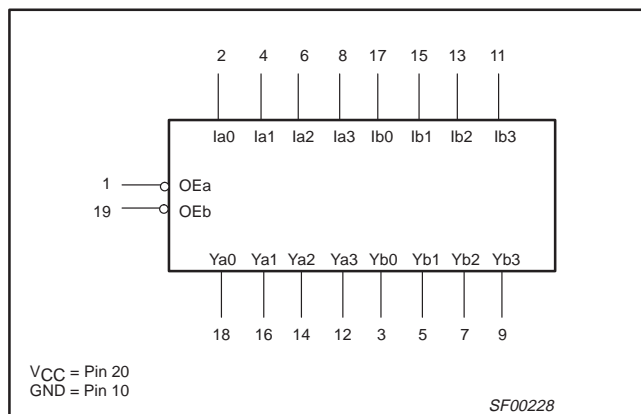

Octal buffer with 30Ω equivalent output termination (3-State)

74F2244

IEC/IEEE SYMBOL

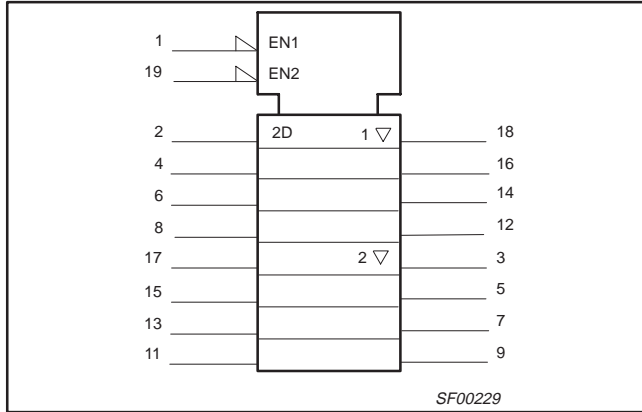

LOGIC DIAGRAM

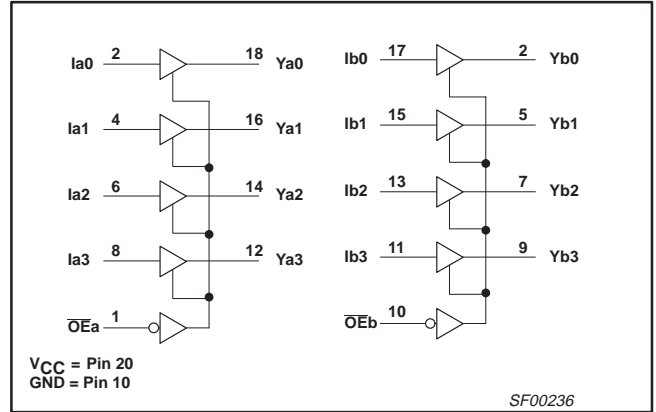

FUNCTION TABLE

INPUTS				OUTPUTS	
OEa	Ia	OEb	Ib	Ya	Yb
L	L	L	L	L	L
L	H	L	H	H	H
H	X	H	X	Z	Z

Notes to function table

- H = High voltage level
- L = Low voltage level
- X = Don't care
- Z = High impedance "off" state

ABSOLUTE MAXIMUM RATINGS

(Operation beyond the limit set forth in this table may impair the useful life of the device. Unless otherwise noted these limits are over the operating free air temperature range.)

SYMBOL	PARAMETER	RATING	UNIT
V _{CC}	Supply voltage	-0.5 to +7.0	V
V _{IN}	Input voltage	-0.5 to +7.0	V
I _{IN}	Input current	-30 to +5	mA
V _{OUT}	Voltage applied to output in high output state	-0.5 to V _{CC}	V
I _{OUT}	Current applied to output in low output state	10	mA
T _{amb}	Operating free air temperature range	0 to +70	°C
T _{stg}	Storage temperature range	-65 to +150	°C

RECOMMENDED OPERATING CONDITIONS

SYMBOL	PARAMETER PARAMETER	LIMITS			UNIT
		MIN	NOM	MAX	
V _{CC}	Supply voltage	4.5	5.0	5.5	V
V _{IH}	High-level input voltage	2.0			V
V _{IL}	Low-level input voltage			0.8	V
I _{Ik}	Input clamp current			-18	mA
I _{OH}	High-level output current			-15	mA
I _{OL}	Low-level output current			5	mA
T _{amb}	Operating free air temperature range	0		+70	°C

Octal buffer with 30Ω equivalent output termination (3-State)

74F2244

DC ELECTRICAL CHARACTERISTICS

(Over recommended operating free-air temperature range unless otherwise noted.)

SYMBOL	PARAMETER	TEST CONDITIONS ¹			LIMITS			UNIT
					MIN	TYP ²	MAX	
V _{OH}	High-level output voltage	V _{CC} = MIN, V _{IL} = MAX, V _{IH} = MIN	I _{OH} = -3mA	±10%V _C	2.5			V
				±5%V _{CC}	2.7	3.4		V
			I _{OH} = -15mA	±10%V _C	2.0			V
				±5%V _{CC}	2.0			V
V _{OL}	Low-level output voltage	V _{CC} = MIN, V _{IL} = MAX, V _{IH} = MIN,	I _{OL} = MAX	±10%V _C			0.50	V
				±5%V _{CC}		0.42	0.50	V
V _{IK}	Input clamp voltage	V _{CC} = MIN, I _I = I _{IK}				-0.73	-1.2	V
I _I	Input current at maximum input voltage	V _{CC} = MAX, V _I = 7.0V					100	μA
I _{IH}	High-level input current	V _{CC} = MAX, V _I = 2.7V					20	μA
I _{IL}	Low-level input current	V _{CC} = MAX, V _I = 0.5V					-0.2	mA
I _{OZH}	Off-state output current, high-level voltage applied	V _{CC} = MAX, V _O = 2.7V					50	μA
I _{OZL}	Off-state output current, low-level voltage applied	V _{CC} = MAX, V _O = 0.5V					-50	μA
I _{OS}	Short-circuit output current ³	V _{CC} = MAX			-60		-150	mA
I _{CC}	Supply current (total)	V _{CC} = MAX	I _{CCH}			20	30	mA
			I _{CCL}			45	65	mA
			I _{CCZ}			26	40	mA

NOTES:

- For conditions shown as MIN or MAX, use the appropriate value specified under recommended operating conditions for the applicable type.
- All typical values are at V_{CC} = 5V, T_{amb} = 25°C.
- Not more than one output should be shorted at a time. For testing I_{OS}, the use of high-speed test apparatus and/or sample-and-hold techniques are preferable in order to minimize internal heating and more accurately reflect operational values. Otherwise, prolonged shorting of a high output may raise the chip temperature well above normal and thereby cause invalid readings in other parameter tests. In any sequence of parameter tests, I_{OS} tests should be performed last.

AC ELECTRICAL CHARACTERISTICS

SYMBOL	PARAMETER	TEST CONDITION	LIMITS					UNIT
			T _{amb} = +25°C V _{CC} = +5.0V C _L = 50pF, R _L = 500Ω			T _{amb} = 0°C to +70°C V _{CC} = +5.0V ± 10% C _L = 50pF, R _L = 500Ω		
			MIN	TYP	MAX	MIN	MAX	
t _{PLH} t _{PHL}	Propagation delay I _{an} , I _{bn} to Y _n	Waveform 1	3.0 2.5	4.5 4.5	7.0 7.0	2.5 2.5	8.0 7.5	ns
t _{PZH} t _{PZL}	Output enable time to high or low level	Waveform 2 Waveform 3	2.5 3.0	4.5 5.0	7.5 8.0	2.0 3.0	8.0 8.5	ns
t _{PHZ} t _{PLZ}	Output disable time from high or low level	Waveform 2 Waveform 3	1.5 1.5	3.5 2.5	6.0 5.5	1.0 1.0	6.0 5.5	ns

Octal buffer with 30Ω equivalent output termination (3-State)

74F2244

AC WAVEFORMS

For all waveforms, $V_M = 1.5V$.

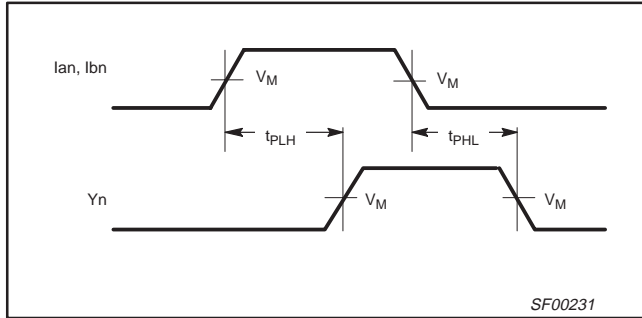

Waveform 1. Propagation delay for data to outputs

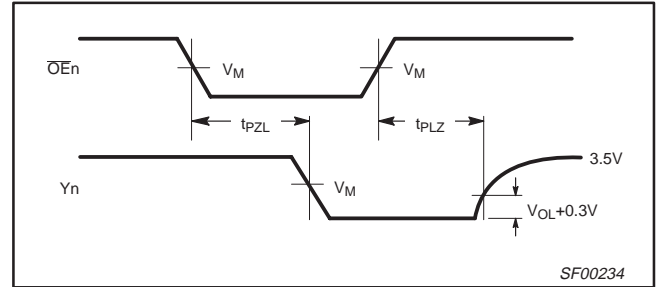

Waveform 3. 3-State output enable time to low level and output disable time from low level

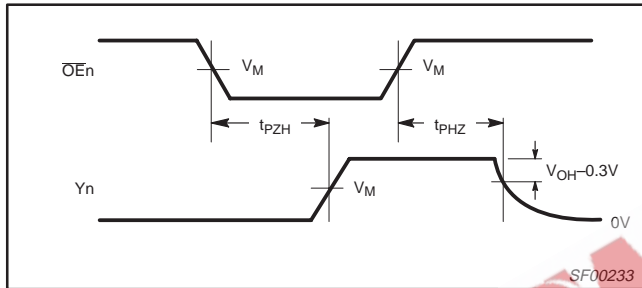

Waveform 2. 3-State output enable time to high level and output disable time from high level

TEST CIRCUIT AND WAVEFORMS

SWITCH POSITION

TEST	SWITCH
t_{PZL} , t_{PLZ}	closed
All other	open

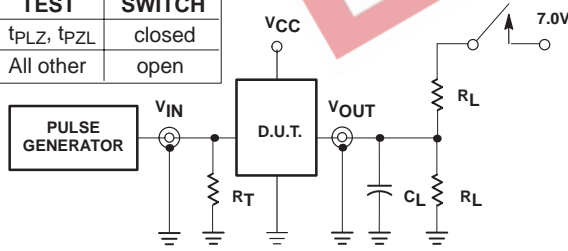

DEFINITIONS:

- R_L = Load resistor; see AC electrical characteristics for value.
- C_L = Load capacitance includes jig and probe capacitance; see AC electrical characteristics for value
- R_T = Termination resistance should be equal to Z_{OUT} of pulse generators.

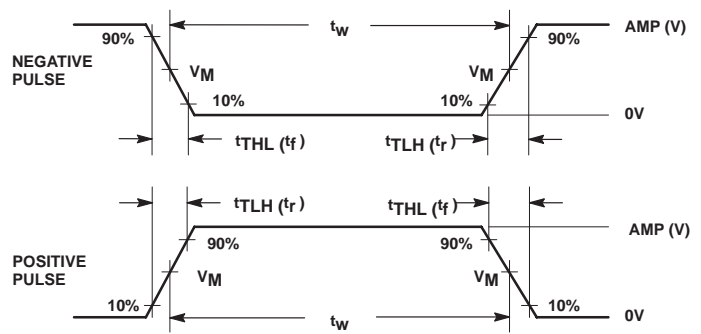

family	INPUT PULSE REQUIREMENTS					
	amplitude	V_M	rep. rate	t_w	t_{TLH}	t_{THL}
74F	3.0V	1.5V	1MHz	500ns	2.5ns	2.5ns

SF000235

Octal buffer with 30Ω equivalent output termination (3-State)

74F2244

DIP20: plastic dual in-line package; 20 leads (300 mil)

SOT146-1

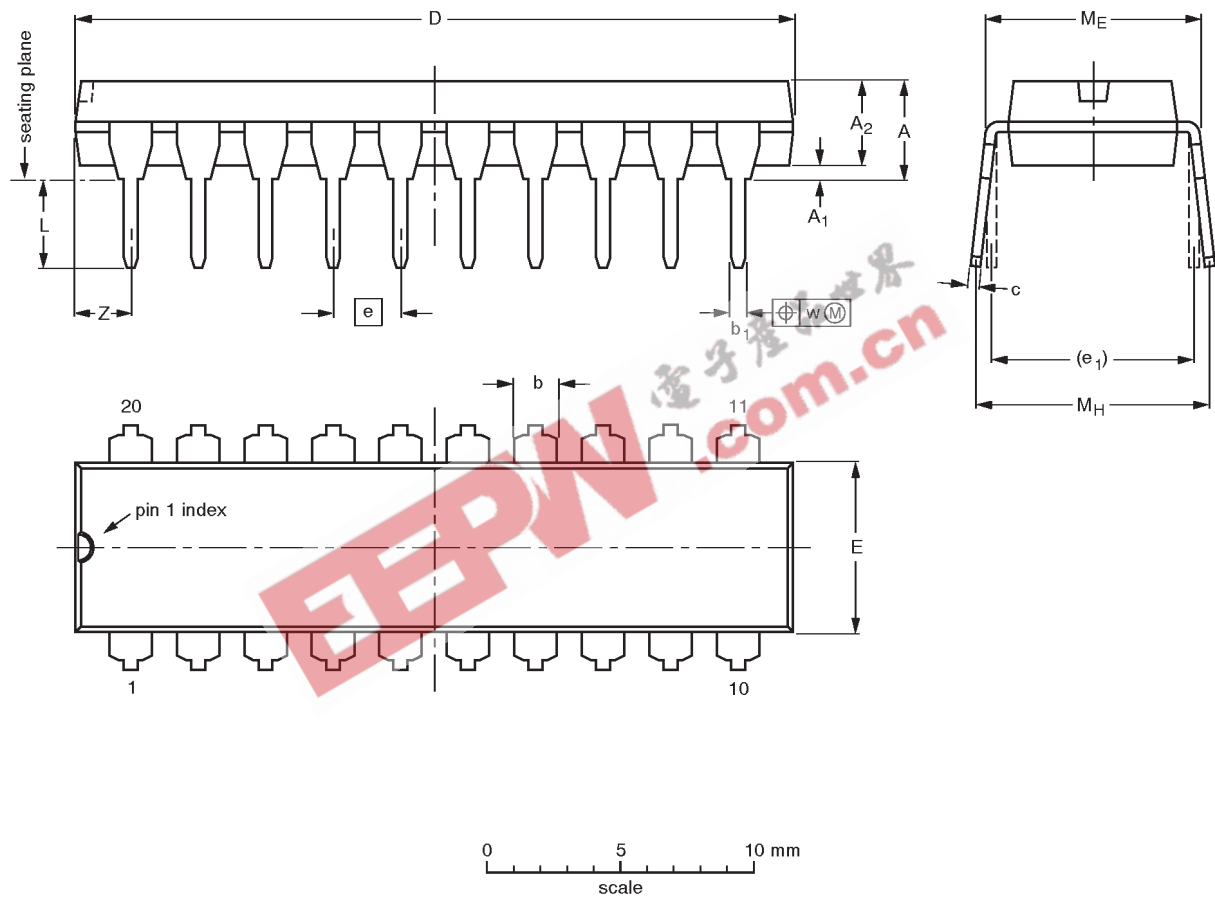

DIMENSIONS (inch dimensions are derived from the original mm dimensions)

UNIT	A max.	A ₁ min.	A ₂ max.	b	b ₁	c	D ⁽¹⁾	E ⁽¹⁾	e	e ₁	L	M _E	M _H	w	Z ⁽¹⁾ max.
mm	4.2	0.51	3.2	1.73 1.30	0.53 0.38	0.36 0.23	26.92 26.54	6.40 6.22	2.54	7.62	3.60 3.05	8.25 7.80	10.0 8.3	0.254	2.0
inches	0.17	0.020	0.13	0.068 0.051	0.021 0.015	0.014 0.009	1.060 1.045	0.25 0.24	0.10	0.30	0.14 0.12	0.32 0.31	0.39 0.33	0.01	0.078

Note

1. Plastic or metal protrusions of 0.25 mm maximum per side are not included.

OUTLINE VERSION	REFERENCES				EUROPEAN PROJECTION	ISSUE DATE
	IEC	JEDEC	EIAJ			
SOT146-1			SC603			92-11-17 95-05-24

Octal buffer with 30Ω equivalent output termination (3-State)

74F2244

SO20: plastic small outline package; 20 leads; body width 7.5 mm

SOT163-1

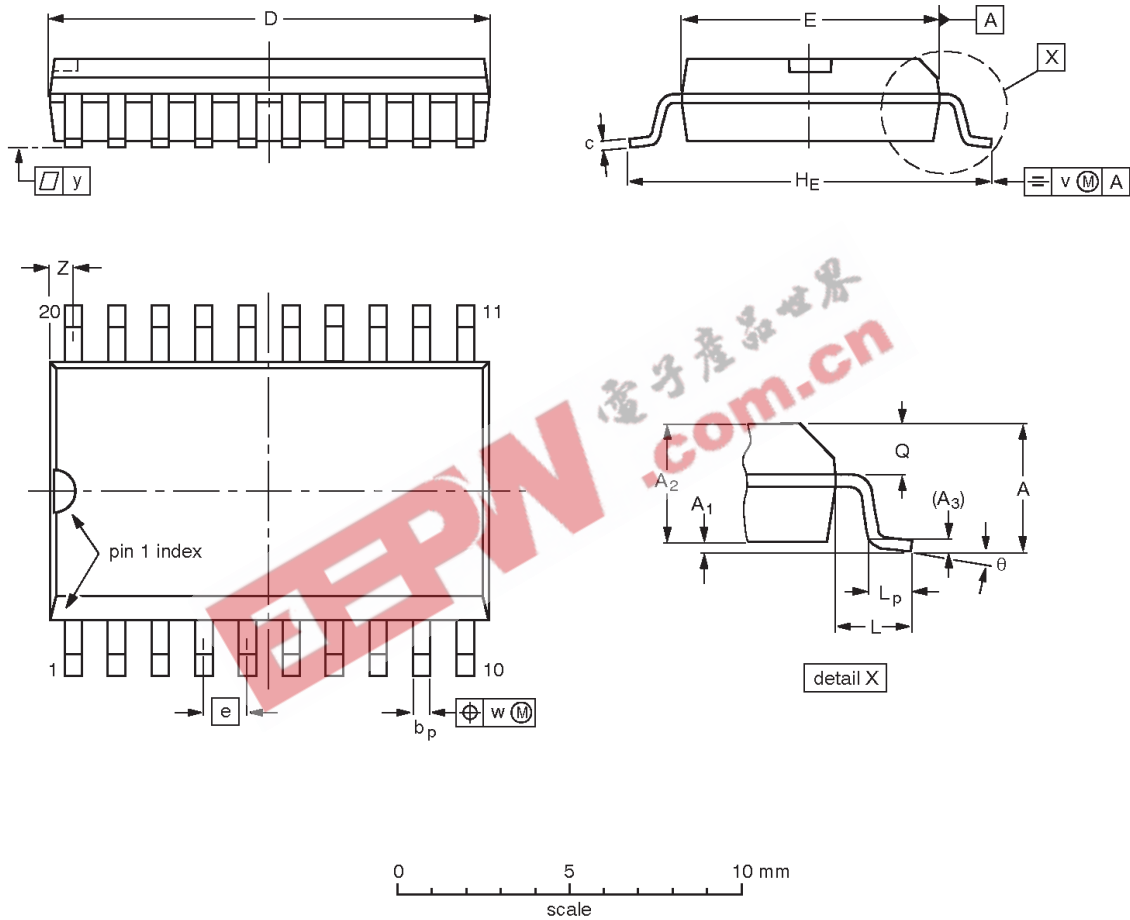

DIMENSIONS (inch dimensions are derived from the original mm dimensions)

UNIT	A max.	A ₁	A ₂	A ₃	b _p	c	D ⁽¹⁾	E ⁽¹⁾	e	H _E	L	L _p	Q	v	w	y	Z ⁽¹⁾	θ
mm	2.65	0.30 0.10	2.45 2.25	0.25	0.49 0.36	0.32 0.23	13.0 12.6	7.6 7.4	1.27	10.65 10.00	1.4	1.1 0.4	1.1 1.0	0.25	0.25	0.1	0.9 0.4	8° 0°
inches	0.10	0.012 0.004	0.096 0.089	0.01	0.019 0.014	0.013 0.009	0.51 0.49	0.30 0.29	0.050	0.419 0.394	0.055	0.043 0.016	0.043 0.039	0.01	0.01	0.004	0.035 0.016	

Note

1. Plastic or metal protrusions of 0.15 mm maximum per side are not included.

OUTLINE VERSION	REFERENCES				EUROPEAN PROJECTION	ISSUE DATE
	IEC	JEDEC	EIAJ			
SOT163-1	075E04	MS-013AC				95-01-24 97-05-22

Octal buffer with 30Ω equivalent output termination (3-State)

74F2244

SSOP20: plastic shrink small outline package; 20 leads; body width 5.3 mm

SOT339-1

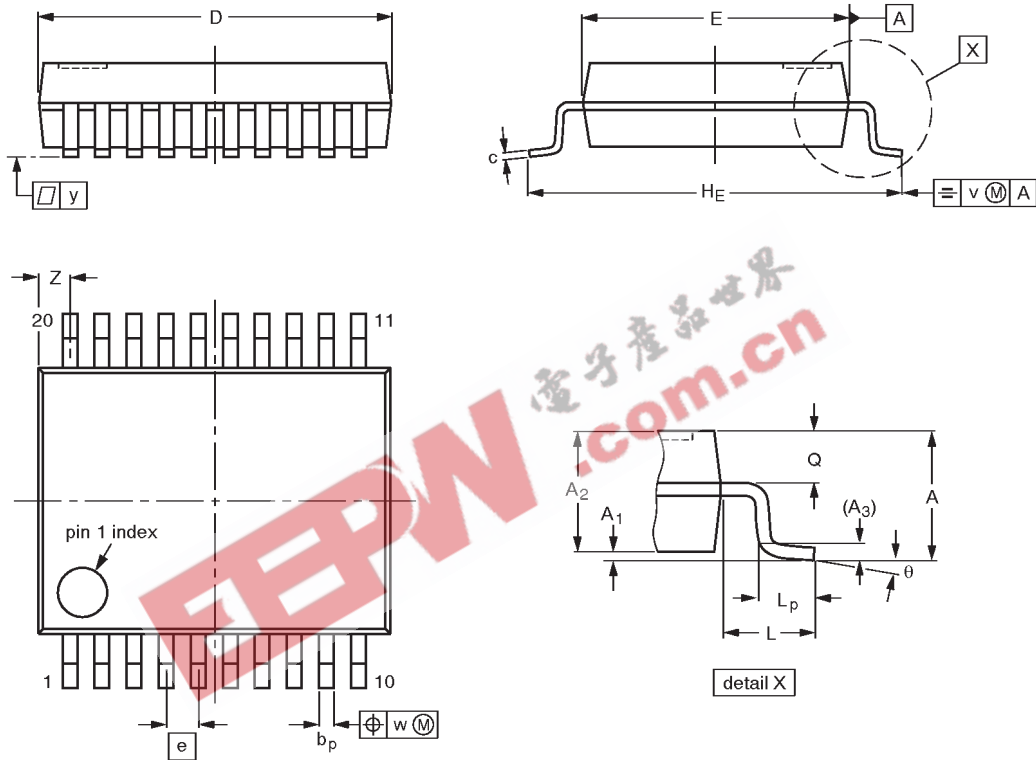

DIMENSIONS (mm are the original dimensions)

UNIT	A max.	A ₁	A ₂	A ₃	b _p	c	D ⁽¹⁾	E ⁽¹⁾	e	H _E	L	L _p	Q	v	w	y	z ⁽¹⁾	θ
mm	2.0	0.21 0.05	1.80 1.65	0.25	0.38 0.25	0.20 0.09	7.4 7.0	5.4 5.2	0.65	7.9 7.6	1.25	1.03 0.63	0.9 0.7	0.2	0.13	0.1	0.9 0.5	8° 0°

Note

1. Plastic or metal protrusions of 0.20 mm maximum per side are not included.

OUTLINE VERSION	REFERENCES				EUROPEAN PROJECTION	ISSUE DATE
	IEC	JEDEC	EIAJ			
SOT339-1		MO-150AE				93-09-08 95-02-04

Octal buffer with 30Ω equivalent output termination (3-State)

74F2244

NOTES



Octal buffer with 30Ω equivalent output termination (3-State)

74F2244

DEFINITIONS

Data Sheet Identification	Product Status	Definition
<i>Objective Specification</i>	Formative or in Design	This data sheet contains the design target or goal specifications for product development. Specifications may change in any manner without notice.
<i>Preliminary Specification</i>	Preproduction Product	This data sheet contains preliminary data, and supplementary data will be published at a later date. Philips Semiconductors reserves the right to make changes at any time without notice in order to improve design and supply the best possible product.
<i>Product Specification</i>	Full Production	This data sheet contains Final Specifications. Philips Semiconductors reserves the right to make changes at any time without notice, in order to improve design and supply the best possible product.

Philips Semiconductors and Philips Electronics North America Corporation reserve the right to make changes, without notice, in the products, including circuits, standard cells, and/or software, described or contained herein in order to improve design and/or performance. Philips Semiconductors assumes no responsibility or liability for the use of any of these products, conveys no license or title under any patent, copyright, or mask work right to these products, and makes no representations or warranties that these products are free from patent, copyright, or mask work right infringement, unless otherwise specified. Applications that are described herein for any of these products are for illustrative purposes only. Philips Semiconductors makes no representation or warranty that such applications will be suitable for the specified use without further testing or modification.

LIFE SUPPORT APPLICATIONS

Philips Semiconductors and Philips Electronics North America Corporation Products are not designed for use in life support appliances, devices, or systems where malfunction of a Philips Semiconductors and Philips Electronics North America Corporation Product can reasonably be expected to result in a personal injury. Philips Semiconductors and Philips Electronics North America Corporation customers using or selling Philips Semiconductors and Philips Electronics North America Corporation Products for use in such applications do so at their own risk and agree to fully indemnify Philips Semiconductors and Philips Electronics North America Corporation for any damages resulting from such improper use or sale.

Philips Semiconductors
811 East Arques Avenue
P.O. Box 3409
Sunnyvale, California 94088-3409
Telephone 800-234-7381

Philips Semiconductors and Philips Electronics North America Corporation register eligible circuits under the Semiconductor Chip Protection Act.
 © Copyright Philips Electronics North America Corporation 1994
 All rights reserved. Printed in U.S.A.

(print code)

Date of release: July 1994

Document order number:

9397-750-05198