

# DATA SHEET

EEPW 电子产品世界  
.com.cn

## 74LVC125

Quad buffer/line driver; 3-State

Product specification  
Supersedes data of February 1996  
IC24 Data Handbook

1997 Mar 18

## Quad buffer/line driver; 3-State

## 74LVC125

## FEATURES

- Wide supply voltage range of 1.2 to 3.6 V
- In accordance with JEDEC standard no. 8-1A
- Inputs accept voltages up to 5.5 V
- CMOS lower power consumption
- Direct interface with TTL levels
- Output drive capability 50  $\Omega$  transmission lines at 85°C

## DESCRIPTION

The 74LVC125 is a high performance, low-power, low-voltage Si-gate CMOS device and superior to most advanced CMOS compatible TTL families.

The 74LVC125 consists of four non-inverting buffers/line drivers with 3-State outputs. The 3-State outputs (nY) are controlled by the output enable input (nOE). A HIGH at nOE causes the outputs to assume a high impedance OFF-state.

## QUICK REFERENCE DATA

GND = 0 V;  $T_{amb} = 25^{\circ}\text{C}$ ;  $t_r = t_f \leq 2.5$  ns

SYMBOL	PARAMETER	CONDITIONS	TYPICAL	UNIT
$t_{PHL}/t_{PLH}$	Propagation delay nA to nY	$C_L = 15$ pF; $V_{CC} = 3.3$ V	3.5	ns
$C_I$	Input capacitance		5.0	pF
$C_{PD}$	Power dissipation capacitance per buffer	Notes 1 and 2	22	pF

## NOTES:

1.  $C_{PD}$  is used to determine the dynamic power dissipation ( $P_D$  in  $\mu\text{W}$ )

$P_D = C_{PD} \times V_{CC}^2 \times f_i + \Sigma (C_L \times V_{CC}^2 \times f_o)$  where:

$f_i$  = input frequency in MHz;  $C_L$  = output load capacity in pF;

$f_o$  = output frequency in MHz;  $V_{CC}$  = supply voltage in V;

$\Sigma (C_L \times V_{CC}^2 \times f_o)$  = sum of the outputs.

2. The condition is  $V_i = \text{GND to } V_{CC}$

## ORDERING INFORMATION

PACKAGES	TEMPERATURE RANGE	OUTSIDE NORTH AMERICA	NORTH AMERICA	PKG. DWG. #
14-Pin Plastic SO	$-40^{\circ}\text{C to } +85^{\circ}\text{C}$	74LVC125 D	74LVC125 D	SOT108-1
14-Pin Plastic SSOP Type II	$-40^{\circ}\text{C to } +85^{\circ}\text{C}$	74LVC125 DB	74LVC125 DB	SOT337-1
14-Pin Plastic TSSOP Type I	$-40^{\circ}\text{C to } +85^{\circ}\text{C}$	74LVC125 PW	74LVC125PW DH	SOT402-1

## PIN CONFIGURATION

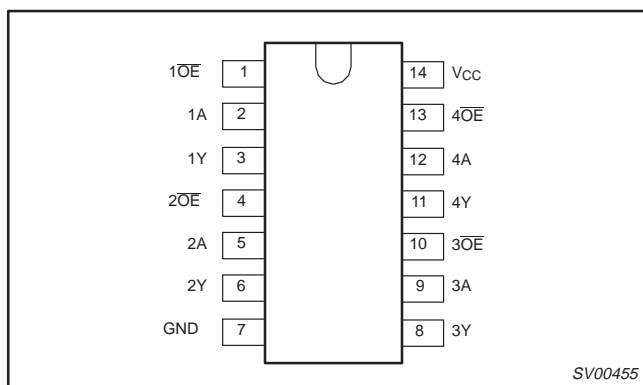

## PIN DESCRIPTION

PIN NUMBER	SYMBOL	NAME AND FUNCTION
1, 4, 10, 13	1OE – 4OE	Data enable inputs (active LOW)
2, 5, 9, 12	1A – 4A	Data inputs
3, 6, 8, 11	1Y – 4Y	Data Outputs
7	GND	Ground (0 V)
14	$V_{CC}$	Positive supply voltage

## LOGIC SYMBOL

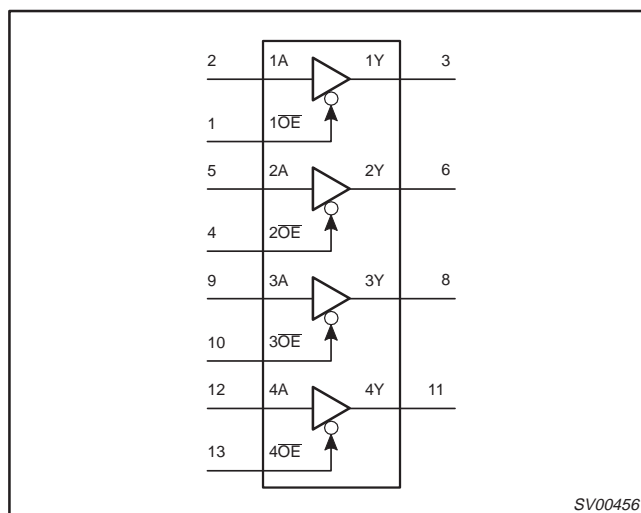

## Quad buffer/line driver; 3-State

74LVC125

## FUNCTION TABLE

INPUTS		OUTPUT
nOE	nA	nY
L	L	L
L	H	H
H	X	Z

## NOTES:

H = HIGH voltage level

L = LOW voltage level

X = don't care

Z = high impedance OFF-state

## LOGIC SYMBOL (IEEE/IEC)

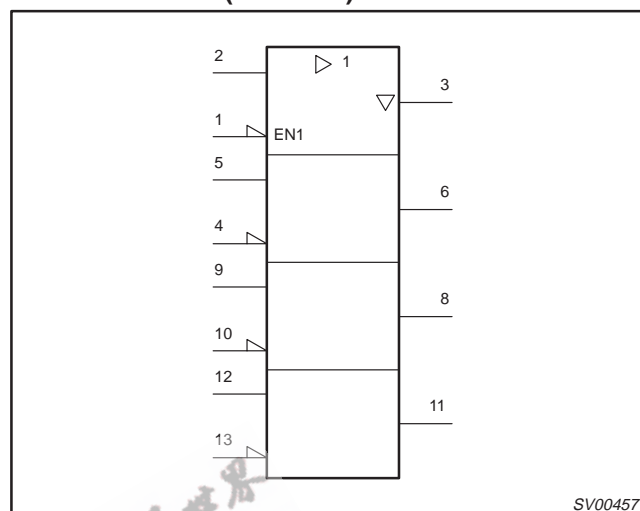

SV00457

## RECOMMENDED OPERATING CONDITIONS

SYMBOL	PARAMETER	CONDITIONS	LIMITS		UNIT
			MIN	MAX	
$V_{CC}$	DC supply voltage (for max. speed performance)		2.7	3.6	V
$V_{CC}$	DC supply voltage (for low-voltage applications)		1.2	3.6	V
$V_I$	DC input voltage range		0	5.5	V
$V_{I/O}$	DC input voltage range for I/Os		0	$V_{CC}$	V
$V_O$	DC output voltage range		0	$V_{CC}$	V
$T_{amb}$	Operating free-air temperature range		-40	+85	°C
$t_r, t_f$	Input rise and fall times	$V_{CC} = 1.2$ to $2.7$ V $V_{CC} = 2.7$ to $3.6$ V	0	20 10	ns/V

ABSOLUTE MAXIMUM RATINGS<sup>1</sup>

In accordance with the Absolute Maximum Rating System (IEC 134).

Voltages are referenced to GND (ground = 0 V).

SYMBOL	PARAMETER	CONDITIONS	RATING	UNIT
$V_{CC}$	DC supply voltage		-0.5 to +6.5	V
$I_{IK}$	DC input diode current	$V_I < 0$	-50	mA
$V_I$	DC input voltage	Note 2	-0.5 to +5.5	V
$V_{I/O}$	DC input voltage range for I/Os		-0.5 to $V_{CC} + 0.5$	V
$I_{OK}$	DC output diode current	$V_O > V_{CC}$ or $V_O < 0$	±50	mA
$V_{OUT}$	DC output voltage	Note 2	-0.5 to $V_{CC} + 0.5$	V
$I_{OUT}$	DC output source or sink current	$V_O = 0$ to $V_{CC}$	±50	mA
$I_{GND}, I_{CC}$	DC $V_{CC}$ or GND current		±100	mA
$T_{stg}$	Storage temperature range		-60 to +150	°C
$P_{TOT}$	Power dissipation per package - plastic mini-pack (SO) - plastic shrink mini-pack (SSOP and TSSOP)	above +70°C derate linearly with 8 mW/K above +60°C derate linearly with 5.5 mW/K	500 500	mW

## NOTES:

- Stresses beyond those listed may cause permanent damage to the device. These are stress ratings only and functional operation of the device at these or any other conditions beyond those indicated under "recommended operating conditions" is not implied. Exposure to absolute-maximum-rated conditions for extended periods may affect device reliability.
- The input and output voltage ratings may be exceeded if the input and output current ratings are observed.

## Quad buffer/line driver; 3-State

## 74LVC125

**DC ELECTRICAL CHARACTERISTICS**

Over recommended operating conditions. Voltages are referenced to GND (ground = 0 V).

SYMBOL	PARAMETER	TEST CONDITIONS	LIMITS			UNIT
			Temp = -40°C to +85°C			
			MIN	TYP <sup>1</sup>	MAX	
V <sub>IH</sub>	HIGH level Input voltage	V <sub>CC</sub> = 1.2V	V <sub>CC</sub>			V
		V <sub>CC</sub> = 2.7 to 3.6V	2.0			
V <sub>IL</sub>	LOW level Input voltage	V <sub>CC</sub> = 1.2V			GND	V
		V <sub>CC</sub> = 2.7 to 3.6V			0.8	
V <sub>OH</sub>	HIGH level output voltage	V <sub>CC</sub> = 2.7V; V <sub>I</sub> = V <sub>IH</sub> or V <sub>IL</sub> ; I <sub>O</sub> = -12mA	V <sub>CC</sub> - 0.5			V
		V <sub>CC</sub> = 3.0V; V <sub>I</sub> = V <sub>IH</sub> or V <sub>IL</sub> ; I <sub>O</sub> = -100μA	V <sub>CC</sub> - 0.2	V <sub>CC</sub>		
		V <sub>CC</sub> = 3.0V; V <sub>I</sub> = V <sub>IH</sub> or V <sub>IL</sub> ; I <sub>O</sub> = -12mA	V <sub>CC</sub> - 0.6			
		V <sub>CC</sub> = 3.0V; V <sub>I</sub> = V <sub>IH</sub> or V <sub>IL</sub> ; I <sub>O</sub> = -24mA	V <sub>CC</sub> - 1.0			
V <sub>OL</sub>	LOW level output voltage	V <sub>CC</sub> = 2.7V; V <sub>I</sub> = V <sub>IH</sub> or V <sub>IL</sub> ; I <sub>O</sub> = 12mA			0.40	V
		V <sub>CC</sub> = 3.0V; V <sub>I</sub> = V <sub>IH</sub> or V <sub>IL</sub> ; I <sub>O</sub> = 100μA		GND	0.20	
		V <sub>CC</sub> = 3.0V; V <sub>I</sub> = V <sub>IH</sub> or V <sub>IL</sub> ; I <sub>O</sub> = 24mA			0.55	
I <sub>I</sub>	Input leakage current	V <sub>CC</sub> = 3.6V; V <sub>I</sub> = 5.5V or GND; Not for I/O pins		± 0.1	± 5	μA
I <sub>IHZ</sub> /I <sub>ILZ</sub>	Input current for common I/O pins	V <sub>CC</sub> = 3.6V; V <sub>I</sub> = V <sub>CC</sub> or GND		± 0.1	± 15	μA
I <sub>OZ</sub>	3-State output OFF-state current	V <sub>CC</sub> = 3.6V; V <sub>I</sub> = V <sub>IH</sub> or V <sub>IL</sub> ; V <sub>O</sub> = V <sub>CC</sub> or GND		0.1	± 10	μA
I <sub>CC</sub>	Quiescent supply current	V <sub>CC</sub> = 3.6V; V <sub>I</sub> = V <sub>CC</sub> or GND; I <sub>O</sub> = 0		0.1	20	μA
ΔI <sub>CC</sub>	Additional quiescent supply current per input pin	V <sub>CC</sub> = 2.7V to 3.6V; V <sub>I</sub> = V <sub>CC</sub> - 0.6V; I <sub>O</sub> = 0		5	500	μA

**NOTE:**1. All typical values are at V<sub>CC</sub> = 3.3V and T<sub>amb</sub> = 25°C.

# Quad buffer/line driver; 3-State

# 74LVC125

## AC CHARACTERISTICS

GND = 0 V;  $t_r = t_f = 2.5$  ns;  $C_L = 50$  pF;  $R_L = 500\Omega$ ;  $T_{amb} = -40^\circ\text{C}$  to  $+85^\circ\text{C}$ .

SYMBOL	PARAMETER	WAVEFORM	LIMITS						UNIT	
			$V_{CC} = 3.3V \pm 0.3V$			$V_{CC} = 2.7V$				$V_{CC} = 1.2V$
			MIN	TYP <sup>1</sup>	MAX	MIN	TYP	MAX		TYP
$t_{PHL}$ $t_{PLH}$	Propagation delay nA to nY	Figure 1, 3		3.5	6.5		3.9	7.0		ns
$t_{PZH}$ $t_{PZL}$	3-state output enable time nOE to nY	Figure 2, 3		3.8	7.0		4.4	8.0		ns
$t_{PHZ}$ $t_{PLZ}$	3-state output disable time nOE to nY	Figure 2, 3		3.3	5.5		4.0	6.5		ns

**NOTE:**

1. These typical values are at  $V_{CC} = 3.3V$  and  $T_{amb} = 25^\circ\text{C}$ .

## AC WAVEFORMS

$V_M = 1.5$  V at  $V_{CC} \geq 2.7$  V

$V_M = 0.5 \times V_{CC}$  at  $V_{CC} < 2.7$  V

$V_{OL}$  and  $V_{OH}$  are the typical output voltage drop that occur with the output load.

$V_X = V_{OL} + 0.3$  V at  $V_{CC} \geq 2.7$  V;

$V_X = V_{OL} + 0.1 \times V_{CC}$  at  $V_{CC} < 2.7$  V;

$V_Y = V_{OH} - 0.3$  V at  $V_{CC} \geq 2.7$  V;

$V_Y = V_{OH} - 0.1 \times V_{CC}$  at  $V_{CC} < 2.7$  V.

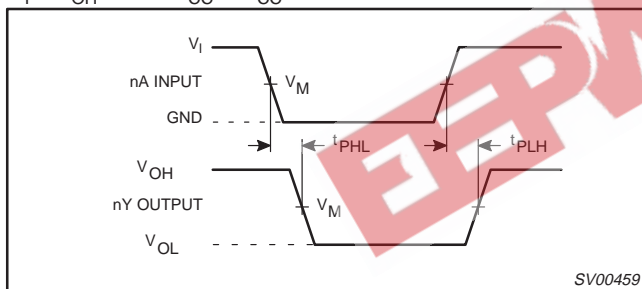

Figure 1. Input (nA) to output (nY) propagation delays.

## TEST CIRCUIT

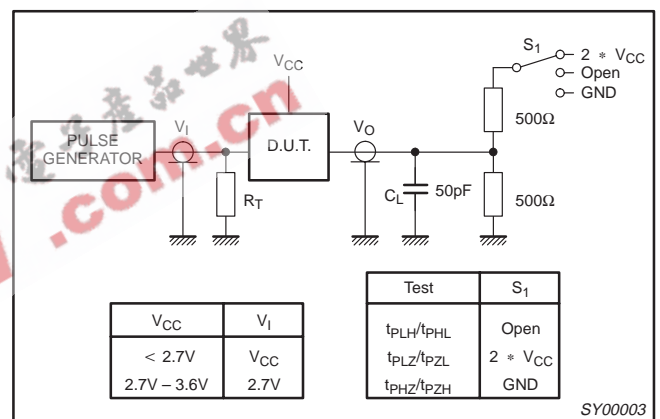

Figure 3. Load circuitry for switching times.

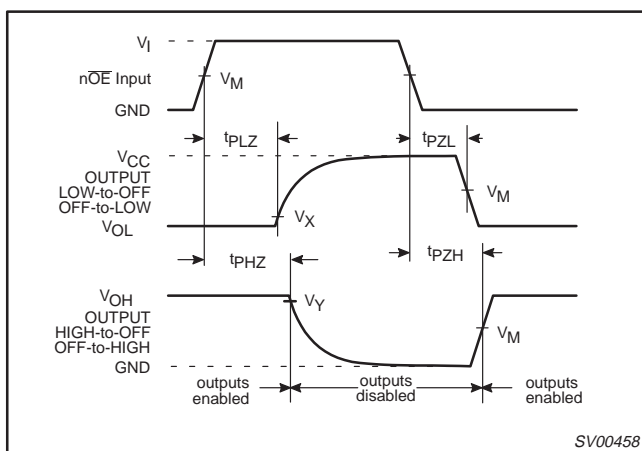

Figure 2. 3-State enable and disable times.

Quad buffer/line driver; 3-State

74LVC125

SO14: plastic small outline package; 14 leads; body width 3.9 mm

SOT108-1

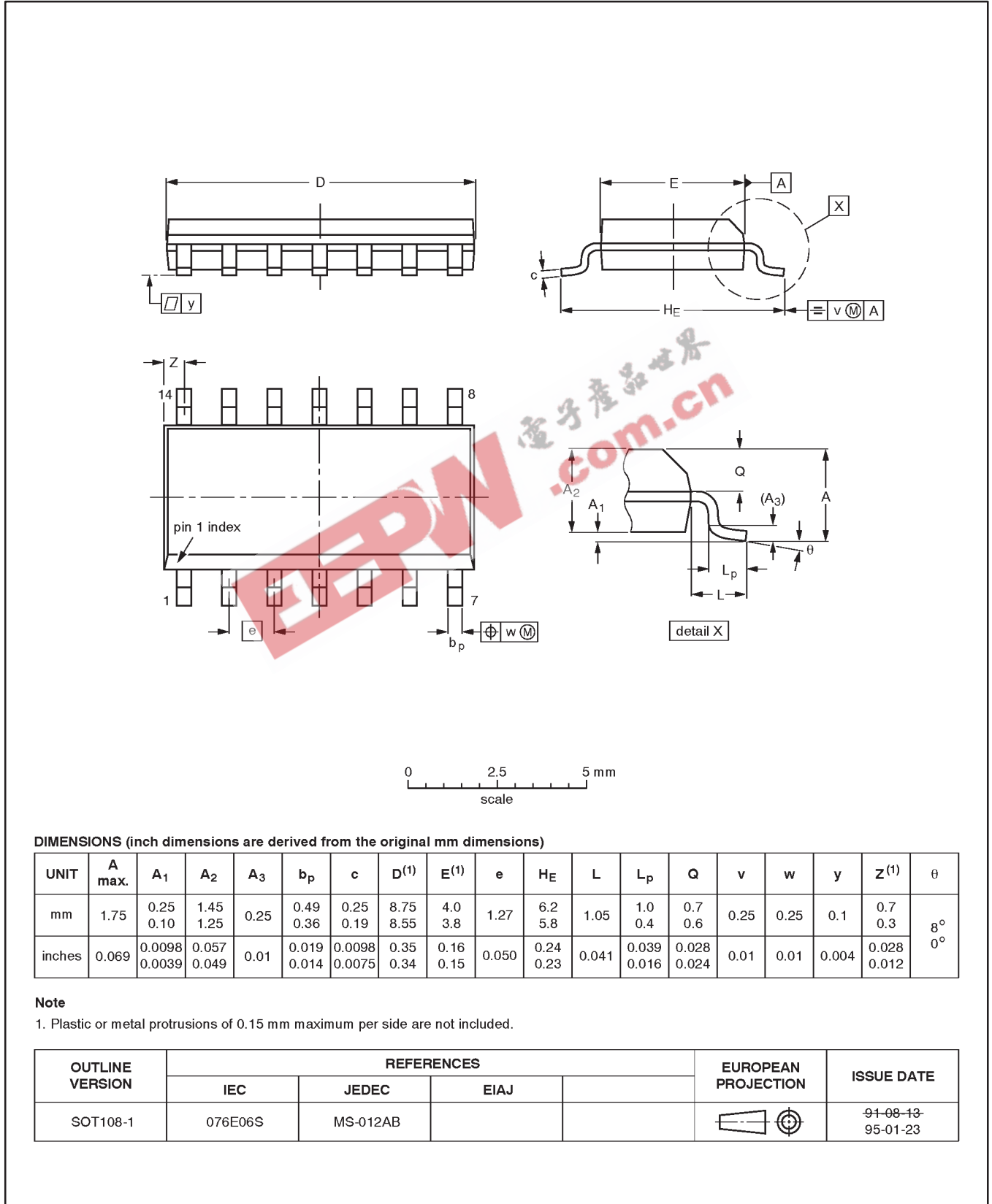

DIMENSIONS (inch dimensions are derived from the original mm dimensions)

UNIT	A max.	A <sub>1</sub>	A <sub>2</sub>	A <sub>3</sub>	b <sub>p</sub>	c	D <sup>(1)</sup>	E <sup>(1)</sup>	e	H <sub>E</sub>	L	L <sub>p</sub>	Q	v	w	y	z <sup>(1)</sup>	θ
mm	1.75	0.25 0.10	1.45 1.25	0.25	0.49 0.36	0.25 0.19	8.75 8.55	4.0 3.8	1.27	6.2 5.8	1.05	1.0 0.4	0.7 0.6	0.25	0.25	0.1	0.7 0.3	8° 0°
inches	0.069	0.0098 0.0039	0.057 0.049	0.01	0.019 0.014	0.0098 0.0075	0.35 0.34	0.16 0.15	0.050	0.24 0.23	0.041	0.039 0.016	0.028 0.024	0.01	0.01	0.004	0.028 0.012	

Note

1. Plastic or metal protrusions of 0.15 mm maximum per side are not included.

OUTLINE VERSION	REFERENCES				EUROPEAN PROJECTION	ISSUE DATE
	IEC	JEDEC	EIAJ			
SOT108-1	076E06S	MS-012AB				91-08-13 95-01-23

Quad buffer/line driver; 3-State

74LVC125

SSOP14: plastic shrink small outline package; 14 leads; body width 5.3 mm

SOT337-1



**DIMENSIONS** (mm are the original dimensions)

UNIT	A max.	A <sub>1</sub>	A <sub>2</sub>	A <sub>3</sub>	b <sub>p</sub>	c	D <sup>(1)</sup>	E <sup>(1)</sup>	e	H <sub>E</sub>	L	L <sub>p</sub>	Q	v	w	y	Z <sup>(1)</sup>	θ
mm	2.0	0.21 0.05	1.80 1.65	0.25	0.38 0.25	0.20 0.09	6.4 6.0	5.4 5.2	0.65	7.9 7.6	1.25	1.03 0.63	0.9 0.7	0.2	0.13	0.1	1.4 0.9	8° 0°

**Note**

1. Plastic or metal protrusions of 0.25 mm maximum per side are not included.

OUTLINE VERSION	REFERENCES				EUROPEAN PROJECTION	ISSUE DATE
	IEC	JEDEC	EIAJ			
SOT337-1		MO-150AB				<del>95-02-04</del> 96-01-18

Quad buffer/line driver; 3-State

74LVC125

TSSOP14: plastic thin shrink small outline package; 14 leads; body width 4.4 mm

SOT402-1

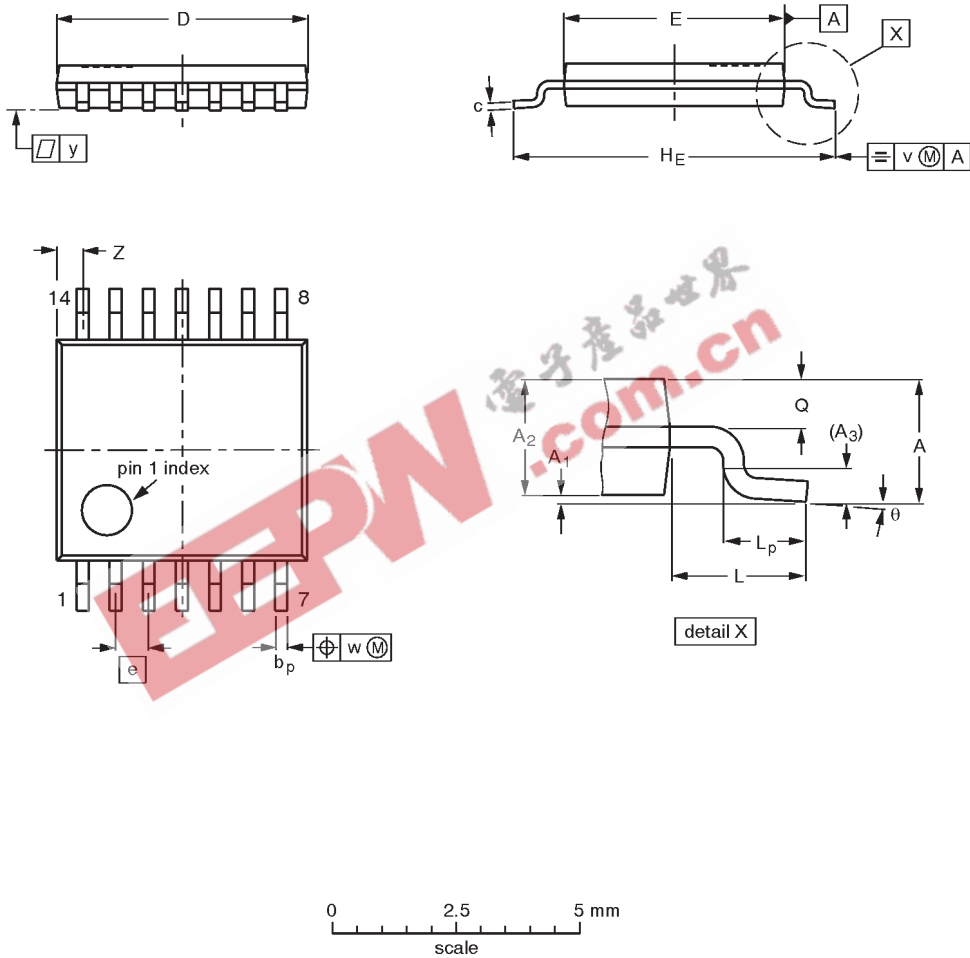

DIMENSIONS (mm are the original dimensions)

UNIT	A max.	A <sub>1</sub>	A <sub>2</sub>	A <sub>3</sub>	b <sub>p</sub>	c	D <sup>(1)</sup>	E <sup>(2)</sup>	e	H <sub>E</sub>	L	L <sub>p</sub>	Q	v	w	y	Z <sup>(1)</sup>	θ
mm	1.10	0.15 0.05	0.95 0.80	0.25	0.30 0.19	0.2 0.1	5.1 4.9	4.5 4.3	0.65	6.6 6.2	1.0	0.75 0.50	0.4 0.3	0.2	0.13	0.1	0.72 0.38	8° 0°

Notes

1. Plastic or metal protrusions of 0.15 mm maximum per side are not included.
2. Plastic interlead protrusions of 0.25 mm maximum per side are not included.

OUTLINE VERSION	REFERENCES				EUROPEAN PROJECTION	ISSUE DATE
	IEC	JEDEC	EIAJ			
SOT402-1		MO-153				-94-07-12- 95-04-04



---

Quad buffer/line driver; 3-State

74LVC125

---

NOTES



## Quad buffer/line driver; 3-State

74LVC125

## DEFINITIONS

Data Sheet Identification	Product Status	Definition
<i>Objective Specification</i>	<b>Formative or in Design</b>	This data sheet contains the design target or goal specifications for product development. Specifications may change in any manner without notice.
<i>Preliminary Specification</i>	<b>Preproduction Product</b>	This data sheet contains preliminary data, and supplementary data will be published at a later date. Philips Semiconductors reserves the right to make changes at any time without notice in order to improve design and supply the best possible product.
<i>Product Specification</i>	<b>Full Production</b>	This data sheet contains Final Specifications. Philips Semiconductors reserves the right to make changes at any time without notice, in order to improve design and supply the best possible product.

Philips Semiconductors and Philips Electronics North America Corporation reserve the right to make changes, without notice, in the products, including circuits, standard cells, and/or software, described or contained herein in order to improve design and/or performance. Philips Semiconductors assumes no responsibility or liability for the use of any of these products, conveys no license or title under any patent, copyright, or mask work right to these products, and makes no representations or warranties that these products are free from patent, copyright, or mask work right infringement, unless otherwise specified. Applications that are described herein for any of these products are for illustrative purposes only. Philips Semiconductors makes no representation or warranty that such applications will be suitable for the specified use without further testing or modification.

## LIFE SUPPORT APPLICATIONS

Philips Semiconductors and Philips Electronics North America Corporation Products are not designed for use in life support appliances, devices, or systems where malfunction of a Philips Semiconductors and Philips Electronics North America Corporation Product can reasonably be expected to result in a personal injury. Philips Semiconductors and Philips Electronics North America Corporation customers using or selling Philips Semiconductors and Philips Electronics North America Corporation Products for use in such applications do so at their own risk and agree to fully indemnify Philips Semiconductors and Philips Electronics North America Corporation for any damages resulting from such improper use or sale.

Philips Semiconductors  
811 East Arques Avenue  
P.O. Box 3409  
Sunnyvale, California 94088-3409  
Telephone 800-234-7381

© Copyright Philips Electronics North America Corporation 1997  
All rights reserved. Printed in U.S.A.

*Let's make things better.*