

54AC11533, 74AC11533 OCTAL D-TYPE TRANSPARENT LATCHES WITH 3-STATE OUTPUTS

SCAS004 – D2957, JULY 1987 – REVISED APRIL 1993

- 8-Latches in a Single Package
- 3-State Bus-Driving Inverting Outputs
- Full Parallel Access for Loading
- Buffered Control Inputs
- Flow-Through Architecture Optimizes PCB Layout
- Center-Pin V_{CC} and GND Configurations Minimize High-Speed Switching Noise
- EPIC™ (Enhanced-Performance Implanted CMOS) 1- μ m Process
- 500-mA Typical Latch-Up Immunity at 125°C
- Package Options Include Plastic Small-Outline Packages, Ceramic Chip Carriers, and Standard Plastic and Ceramic 300-mil DIPs

54AC11533 . . . JT PACKAGE
74AC11533 . . . DW OR NT PACKAGE
(TOP VIEW)

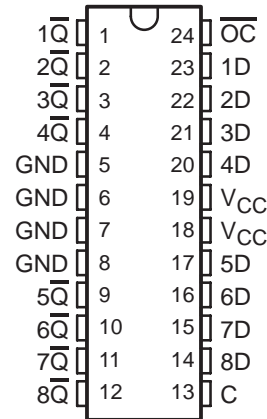

description

These 8-bit latches feature 3-state outputs designed specifically for driving highly capacitive or relatively low-impedance loads. They are particularly suitable for implementing buffer registers, I/O ports, bidirectional bus drivers, and working registers.

The eight latches of the 'AC11533 are transparent D-type latches. While the enable (C) is high, the \bar{Q} outputs will follow the complements of the (D) inputs. When the output control \bar{OC} is taken low, the \bar{Q} outputs will be latched. The 'AC11533 is functionally equivalent to the 'AC11373 except for having inverted outputs.

A buffered output-control (\bar{OC}) input can be used to place the eight outputs in either a normal logic state (high or low logic levels) or a high-impedance state. In the high-impedance state, the outputs neither load nor drive the bus lines significantly. The high-impedance third state and increased drive provide the capability to drive the bus lines in a bus-organized system without need for interface or pull-up components.

The output control (\bar{OC}) does not affect the internal operations of the latches. Old data can be retained or new data can be entered while the outputs are off.

The 54AC11533 is characterized for operation over the full military temperature range of -55°C to 125°C . The 74AC11533 is characterized for operation from -40°C to 85°C .

54AC11533 . . . FK PACKAGE
(TOP VIEW)

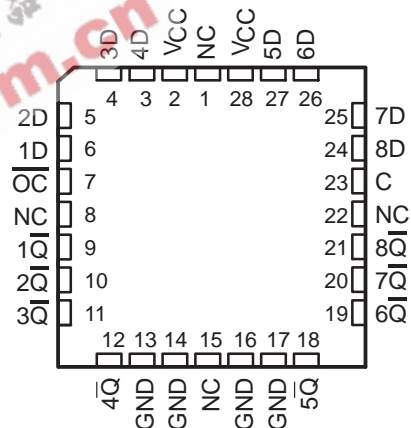

NC – No internal connection

EPIC is a trademark of Texas Instruments Incorporated.

PRODUCTION DATA information is current as of publication date. Products conform to specifications per the terms of Texas Instruments standard warranty. Production processing does not necessarily include testing of all parameters.

TEXAS
INSTRUMENTS

POST OFFICE BOX 655303 • DALLAS, TEXAS 75265
POST OFFICE BOX 1443 • HOUSTON, TEXAS 77001

Copyright © 1993, Texas Instruments Incorporated

54AC11533, 74AC11533 OCTAL D-TYPE TRANSPARENT LATCHES WITH 3-STATE OUTPUTS

SCAS004 – D2957, JULY 1987 – REVISED APRIL 1993

FUNCTION TABLE
(each latch)

INPUTS			OUTPUT
\overline{OC}	C	D	Q
L	H	H	L
L	H	L	H
L	L	X	$\overline{Q_0}$
H	X	X	Z

logic symbol†

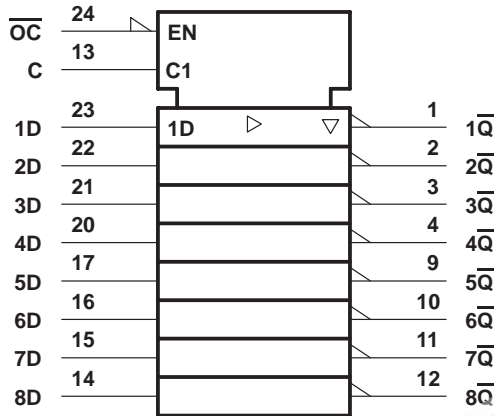

† This symbol is in accordance with ANSI/IEEE Std 91-1984 and IEC Publication 617-12.

logic diagram (positive logic)

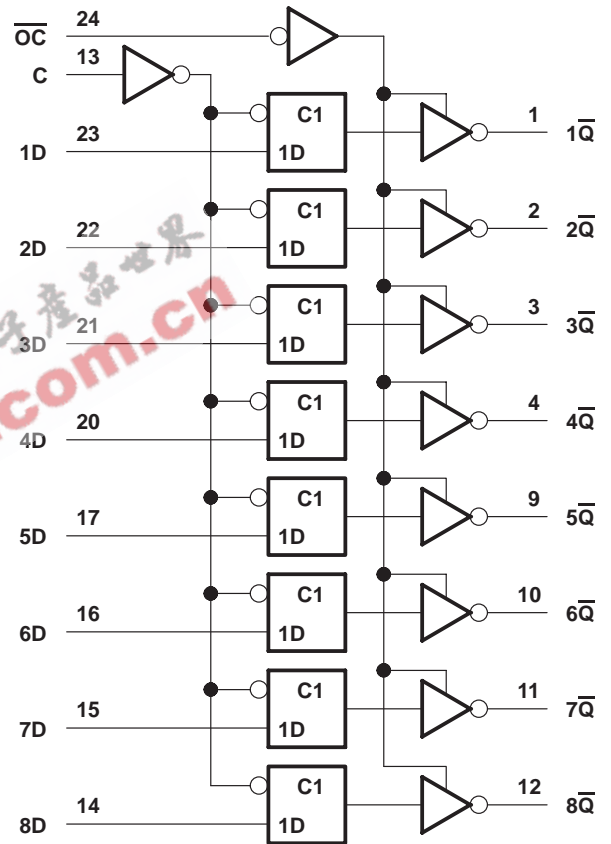

Pin numbers shown are for the DW, JT, and NT packages.

absolute maximum ratings over operating free-air temperature range (unless otherwise noted)‡

Supply voltage range, V_{CC}	-0.5 V to 6 V
Input voltage range, V_I (see Note 1)	-0.5 V to $V_{CC} + 0.5$ V
Output voltage range, V_O (see Note 1)	-0.5 V to $V_{CC} + 0.5$ V
Input clamp current, I_{IK} ($V_I < 0$ or $V_I > V_{CC}$)	± 20 mA
Output clamp current, I_{OK} ($V_O < 0$ or $V_O > V_{CC}$)	± 50 mA
Continuous output current, I_O ($V_O = 0$ to V_{CC})	± 50 mA
Continuous current through V_{CC} or GND	± 200 mA
Storage temperature range	-65°C to 150°C

‡ Stresses beyond those listed under “absolute maximum ratings” may cause permanent damage to the device. These are stress ratings only and functional operation of the device at these or any other conditions beyond those indicated under “recommended operating conditions” is not implied. Exposure to absolute-maximum-rated conditions for extended periods may affect device reliability.

NOTE 1: The input and output voltage ratings may be exceeded if the input and output current ratings are observed.

54AC11533, 74AC11533 OCTAL D-TYPE TRANSPARENT LATCHES WITH 3-STATE OUTPUTS

SCAS004 – D2957, JULY 1987 – REVISED APRIL 1993

recommended operating conditions

		54AC11533			74AC11533			UNIT
		MIN	NOM	MAX	MIN	NOM	MAX	
V _{CC}	Supply voltage	3	5	5.5	3	5	5.5	V
V _{IH}	High-level input voltage	V _{CC} = 3 V		2.1	2.1		V	
		V _{CC} = 4.5 V		3.15	3.15			
		V _{CC} = 5.5 V		3.85	3.85			
V _{IL}	Low-level input voltage	V _{CC} = 3 V			0.9		V	
		V _{CC} = 4.5 V			1.35			
		V _{CC} = 5.5 V			1.65			
V _I	Input voltage	0		V _{CC}	0		V _{CC}	V
V _O	Output voltage	0		V _{CC}	0		V _{CC}	V
I _{OH}	High-level output current	V _{CC} = 3 V			-4		mA	
		V _{CC} = 4.5 V			-24			
		V _{CC} = 5.5 V			-24			
I _{OL}	Low-level output current	V _{CC} = 3 V			12		mA	
		V _{CC} = 4.5 V			24			
		V _{CC} = 5.5 V			24			
Δt/Δv	Input transition rise or fall rate	0		10	0		10	ns/V
T _A	Operating free-air temperature	-55		125	-40		85	°C

electrical characteristics over recommended operating free-air temperature range (unless otherwise noted)

PARAMETER	TEST CONDITIONS	V _{CC}	T _A = 25°C			54AC11533		74AC11533		UNIT
			MIN	TYP	MAX	MIN	MAX	MIN	MAX	
V _{OH}	I _{OH} = -50 μA	3 V	2.9			2.9		2.9	V	
		4.5 V	4.4			4.4		4.4		
		5.5 V	5.4			5.4		5.4		
	I _{OH} = -4 mA	3 V	2.58			2.4		2.48		
		4.5 V	3.94			3.7		3.8		
	I _{OH} = -24 mA	5.5 V	4.94			4.7		4.8		
		5.5 V				3.85				
V _{OL}	I _{OL} = 50 μA	3 V				0.1		0.1	V	
		4.5 V				0.1		0.1		
		5.5 V				0.1		0.1		
	I _{OL} = 12 mA	3 V				0.36		0.44		
		4.5 V				0.36		0.44		
	I _{OL} = 24 mA	5.5 V				0.36		0.44		
		5.5 V					1.65			
I _{OL} = 75 mA†	5.5 V						1.65			
	5.5 V						1.65			
I _{OZ}	V _O = V _{CC} or GND	5.5 V			±0.5		±10	±5	μA	
I _I	V _I = V _{CC} or GND	5.5 V			±0.1		±1	±1	μA	
I _{CC}	V _I = V _{CC} or GND, I _O = 0	5.5 V			8		160	80	μA	
C _i	V _I = V _{CC} or GND	5 V			4				pF	
C _o	V _O = V _{CC} or GND	5 V			10				pF	

† Not more than one output should be tested at a time, and the duration of the test should not exceed 10 ms.



54AC11533, 74AC11533 OCTAL D-TYPE TRANSPARENT LATCHES WITH 3-STATE OUTPUTS

SCAS004 – D2957, JULY 1987 – REVISED APRIL 1993

timing requirements (see Figure 1)

	V _{CC} RANGE	T _A = 25°C		54AC11533		74AC11533		UNIT
		MIN	MAX	MIN	MAX	MIN	MAX	
t _w Pulse duration, C high	3.3 ± 0.3 V	5.5		5.5		5.5		ns
	5 ± 0.5 V	4		4		4		
t _{su} Setup time, data before C	3.3 ± 0.3 V	4		4		4		ns
	5 ± 0.5 V	3.5		3.5		3.5		
t _h Hold time, data after C↓	3.3 ± 0.3 V	2		2		2		ns
	5 ± 0.5 V	2		2		2		

switching characteristics over recommended operating free-air temperature range, V_{CC} = 3.3 V ± 0.3 V (unless otherwise noted) (see Figure 1)

PARAMETER	FROM (INPUT)	TO (OUTPUT)	T _A = 25°C			54AC11533		74AC11533		UNIT
			MIN	TYP	MAX	MIN	MAX	MIN	MAX	
t _{PLH}	D	Q̄	1.5	8.5	12.6	1.5	15.2	1.5	14.3	ns
t _{PHL}			1.5	7.5	10.1	1.5	12	1.5	11.3	
t _{PLH}	C	Any Q̄	1.5	10	14.5	1.5	17.6	1.5	16.5	ns
t _{PHL}			1.5	9.5	12.8	1.5	15.2	1.5	14.3	
t _{PZH}	OC̄	Any Q̄	1.5	9	13.1	1.5	15.7	1.5	14.7	ns
t _{PZL}			1.5	8.5	11.6	1.5	14.1	1.5	13.1	
t _{PHZ}	OC̄	Any Q̄	1.5	9.5	12	1.5	13.2	1.5	12.8	ns
t _{PLZ}			1.5	7.5	10.2	1.5	11.4	1.5	11	

switching characteristics over recommended operating free-air temperature range, V_{CC} = 5 V ± 0.5 V (unless otherwise noted) (see Figure 1)

PARAMETER	FROM (INPUT)	TO (OUTPUT)	T _A = 25°C			54AC11533		74AC11533		UNIT
			MIN	TYP	MAX	MIN	MAX	MIN	MAX	
t _{PLH}	D	Q̄	1.5	5.5	8.4	1.5	10.6	1.5	9.8	ns
t _{PHL}			1.5	5	7.1	1.5	8.6	1.5	8	
t _{PLH}	C	Any Q̄	1.5	6.5	10	1.5	12.1	1.5	11.3	ns
t _{PHL}			1.5	6.5	9.1	1.5	11	1.5	10.3	
t _{PZH}	OC̄	Any Q̄	1.5	6.5	9.5	1.5	11.7	1.5	10.8	ns
t _{PZL}			1.5	6	8.6	1.5	10.9	1.5	9.7	
t _{PHZ}	OC̄	Any Q̄	1.5	8.5	10.7	1.5	11.7	1.5	11.4	ns
t _{PLZ}			1.5	6	8.2	1.5	9.3	1.5	8.9	

operating characteristics, V_{CC} = 5 V, T_A = 25°C

PARAMETER		TEST CONDITIONS	TYP	UNIT
C _{pd}	Power dissipation capacitance per latch	C _L = 50 pF, f = 1 MHz	55	pF
			44	

54AC11533, 74AC11533 OCTAL D-TYPE TRANSPARENT LATCHES WITH 3-STATE OUTPUTS

SCAS004 – D2957, JULY 1987 – REVISED APRIL 1993

PARAMETER MEASUREMENT INFORMATION

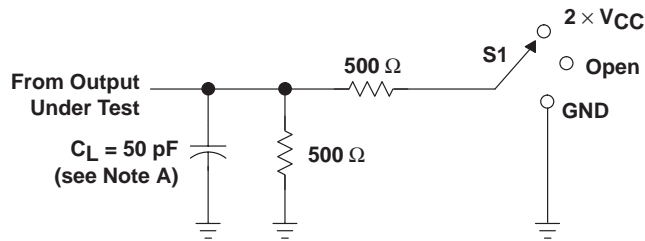

TEST	S1
t_{PLH}/t_{PHL}	Open
t_{PLZ}/t_{PZL}	$2 \times V_{CC}$
t_{PHZ}/t_{PZH}	GND

LOAD CIRCUIT

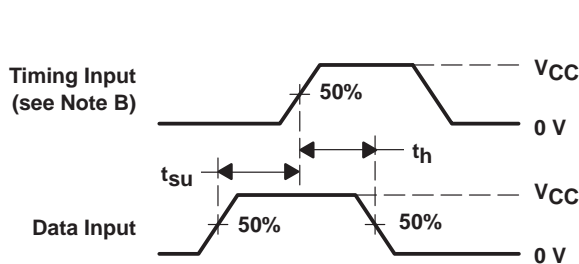

VOLTAGE WAVEFORMS

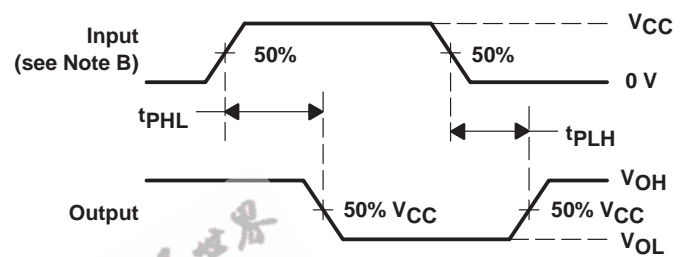

VOLTAGE WAVEFORMS

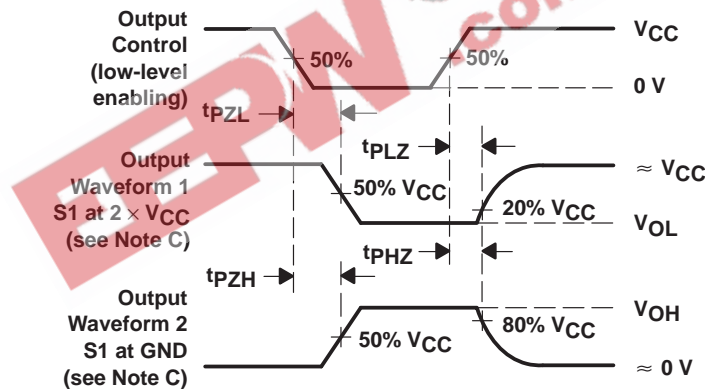

VOLTAGE WAVEFORMS

- NOTES: A. C_L includes probe and jig capacitance.
 B. All input pulses are supplied by generators having the following characteristics: $PRR \leq 10$ MHz, $Z_O = 50 \Omega$, $t_r = 3$ ns, $t_f = 3$ ns.
 C. Waveform 1 is for an output with internal conditions such that the output is low except when disabled by the output control. Waveform 2 is for an output with internal conditions such that the output is high except when disabled by the output control.
 D. The outputs are measured one at a time with one input transition per measurement.

Figure 1. Load Circuit and Voltage Waveforms

EEPW 电子产品世界
.com.cn

PACKAGING INFORMATION

Orderable Device	Status ⁽¹⁾	Package Type	Package Drawing	Pins	Package Qty	Eco Plan ⁽²⁾	Lead/Ball Finish	MSL Peak Temp ⁽³⁾
74AC11533DW	OBSOLETE	SOIC	DW	24		TBD	Call TI	Call TI
74AC11533NT	OBSOLETE	PDIP	NT	24		TBD	Call TI	Call TI
74AC11533NT	OBSOLETE	PDIP	NT	24		TBD	Call TI	Call TI
74AC11533NT	OBSOLETE	PDIP	NT	24		TBD	Call TI	Call TI

⁽¹⁾ The marketing status values are defined as follows:

ACTIVE: Product device recommended for new designs.

LIFEBUY: TI has announced that the device will be discontinued, and a lifetime-buy period is in effect.

NRND: Not recommended for new designs. Device is in production to support existing customers, but TI does not recommend using this part in a new design.

PREVIEW: Device has been announced but is not in production. Samples may or may not be available.

OBSOLETE: TI has discontinued the production of the device.

⁽²⁾ Eco Plan - The planned eco-friendly classification: Pb-Free (RoHS) or Green (RoHS & no Sb/Br) - please check <http://www.ti.com/productcontent> for the latest availability information and additional product content details.

TBD: The Pb-Free/Green conversion plan has not been defined.

Pb-Free (RoHS): TI's terms "Lead-Free" or "Pb-Free" mean semiconductor products that are compatible with the current RoHS requirements for all 6 substances, including the requirement that lead not exceed 0.1% by weight in homogeneous materials. Where designed to be soldered at high temperatures, TI Pb-Free products are suitable for use in specified lead-free processes.

Green (RoHS & no Sb/Br): TI defines "Green" to mean Pb-Free (RoHS compatible), and free of Bromine (Br) and Antimony (Sb) based flame retardants (Br or Sb do not exceed 0.1% by weight in homogeneous material)

⁽³⁾ MSL, Peak Temp. -- The Moisture Sensitivity Level rating according to the JEDEC industry standard classifications, and peak solder temperature.

Important Information and Disclaimer: The information provided on this page represents TI's knowledge and belief as of the date that it is provided. TI bases its knowledge and belief on information provided by third parties, and makes no representation or warranty as to the accuracy of such information. Efforts are underway to better integrate information from third parties. TI has taken and continues to take reasonable steps to provide representative and accurate information but may not have conducted destructive testing or chemical analysis on incoming materials and chemicals. TI and TI suppliers consider certain information to be proprietary, and thus CAS numbers and other limited information may not be available for release.

In no event shall TI's liability arising out of such information exceed the total purchase price of the TI part(s) at issue in this document sold by TI to Customer on an annual basis.

IMPORTANT NOTICE

Texas Instruments Incorporated and its subsidiaries (TI) reserve the right to make corrections, modifications, enhancements, improvements, and other changes to its products and services at any time and to discontinue any product or service without notice. Customers should obtain the latest relevant information before placing orders and should verify that such information is current and complete. All products are sold subject to TI's terms and conditions of sale supplied at the time of order acknowledgment.

TI warrants performance of its hardware products to the specifications applicable at the time of sale in accordance with TI's standard warranty. Testing and other quality control techniques are used to the extent TI deems necessary to support this warranty. Except where mandated by government requirements, testing of all parameters of each product is not necessarily performed.

TI assumes no liability for applications assistance or customer product design. Customers are responsible for their products and applications using TI components. To minimize the risks associated with customer products and applications, customers should provide adequate design and operating safeguards.

TI does not warrant or represent that any license, either express or implied, is granted under any TI patent right, copyright, mask work right, or other TI intellectual property right relating to any combination, machine, or process in which TI products or services are used. Information published by TI regarding third-party products or services does not constitute a license from TI to use such products or services or a warranty or endorsement thereof. Use of such information may require a license from a third party under the patents or other intellectual property of the third party, or a license from TI under the patents or other intellectual property of TI.

Reproduction of TI information in TI data books or data sheets is permissible only if reproduction is without alteration and is accompanied by all associated warranties, conditions, limitations, and notices. Reproduction of this information with alteration is an unfair and deceptive business practice. TI is not responsible or liable for such altered documentation. Information of third parties may be subject to additional restrictions.

Resale of TI products or services with statements different from or beyond the parameters stated by TI for that product or service voids all express and any implied warranties for the associated TI product or service and is an unfair and deceptive business practice. TI is not responsible or liable for any such statements.

TI products are not authorized for use in safety-critical applications (such as life support) where a failure of the TI product would reasonably be expected to cause severe personal injury or death, unless officers of the parties have executed an agreement specifically governing such use. Buyers represent that they have all necessary expertise in the safety and regulatory ramifications of their applications, and acknowledge and agree that they are solely responsible for all legal, regulatory and safety-related requirements concerning their products and any use of TI products in such safety-critical applications, notwithstanding any applications-related information or support that may be provided by TI. Further, Buyers must fully indemnify TI and its representatives against any damages arising out of the use of TI products in such safety-critical applications.

TI products are neither designed nor intended for use in military/aerospace applications or environments unless the TI products are specifically designated by TI as military-grade or "enhanced plastic." Only products designated by TI as military-grade meet military specifications. Buyers acknowledge and agree that any such use of TI products which TI has not designated as military-grade is solely at the Buyer's risk, and that they are solely responsible for compliance with all legal and regulatory requirements in connection with such use.

TI products are neither designed nor intended for use in automotive applications or environments unless the specific TI products are designated by TI as compliant with ISO/TS 16949 requirements. Buyers acknowledge and agree that, if they use any non-designated products in automotive applications, TI will not be responsible for any failure to meet such requirements.

Following are URLs where you can obtain information on other Texas Instruments products and application solutions:

Products		Applications	
Amplifiers	amplifier.ti.com	Audio	www.ti.com/audio
Data Converters	dataconverter.ti.com	Automotive	www.ti.com/automotive
DSP	dsp.ti.com	Broadband	www.ti.com/broadband
Interface	interface.ti.com	Digital Control	www.ti.com/digitalcontrol
Logic	logic.ti.com	Military	www.ti.com/military
Power Mgmt	power.ti.com	Optical Networking	www.ti.com/opticalnetwork
Microcontrollers	microcontroller.ti.com	Security	www.ti.com/security
RFID	www.ti-rfid.com	Telephony	www.ti.com/telephony
Low Power Wireless	www.ti.com/lpw	Video & Imaging	www.ti.com/video
		Wireless	www.ti.com/wireless

Mailing Address: Texas Instruments, Post Office Box 655303, Dallas, Texas 75265
Copyright © 2007, Texas Instruments Incorporated