

DATA SHEET

For a complete data sheet, please also download:

- The IC06 74HC/HCT/HCU/HCMOS Logic Family Specifications
- The IC06 74HC/HCT/HCU/HCMOS Logic Package Information
- The IC06 74HC/HCT/HCU/HCMOS Logic Package Outlines

EEPW 电子產品世界
.com.cn

74HC/HCT640

Octal bus transceiver; 3-state;
inverting

Product specification
File under Integrated Circuits, IC06

March 1988

Octal bus transceiver; 3-state; inverting

74HC/HCT640

FEATURES

- Octal bidirectional bus interface
- Inverting 3-state outputs
- Output capability: bus driver
- I_{CC} category: MSI

GENERAL DESCRIPTION

The 74HC/HCT640 are high-speed Si-gate CMOS devices and are pin compatible with low power Schottky TTL (LSTTL). They are specified in compliance with JEDEC standard no. 7A.

The 74HC/HCT640 are octal transceivers featuring inverting 3-state bus compatible outputs in both send and receive directions.

The "640" features an output enable (\overline{OE}) input for easy cascading and a send/receive (DIR) for direction control. \overline{OE} controls the outputs so that the buses are effectively isolated. The "640" is similar to the "245" but has inverting outputs.

QUICK REFERENCE DATA

GND = 0 V; T_{amb} = 25 °C; t_r = t_f = 6 ns

SYMBOL	PARAMETER	CONDITIONS	TYPICAL		UNIT
			HC	HCT	
t _{PHL} /t _{PLH}	propagation delay A _n to B _n ; B _n to A _n	C _L = 15 pF; V _{CC} = 5 V	9	9	ns
C _I	input capacitance		3.5	3.5	pF
C _{I/O}	input/output capacitance		10	10	pF
C _{PD}	power dissipation capacitance per transceiver	notes 1 and 2	35	35	pF

Notes

1. C_{PD} is used to determine the dynamic power dissipation (P_D in μW):

$$P_D = C_{PD} \times V_{CC}^2 \times f_i + \sum (C_L \times V_{CC}^2 \times f_o) \text{ where:}$$

f_i = input frequency in MHz

f_o = output frequency in MHz

$\sum (C_L \times V_{CC}^2 \times f_o)$ = sum of outputs

C_L = output load capacitance in pF

V_{CC} = supply voltage in V

2. For HC the condition is V_I = GND to V_{CC}
For HCT the condition is V_I = GND to V_{CC} – 1.5 V

ORDERING INFORMATION

See "74HC/HCT/HCU/HCMOS Logic Package Information".

Octal bus transceiver; 3-state; inverting

74HC/HCT640

PIN DESCRIPTION

PIN NO.	SYMBOL	NAME AND FUNCTION
1	DIR	direction control
2, 3, 4, 5, 6, 7, 8, 9	A ₀ to A ₇	data inputs/outputs
10	GND	ground (0 V)
18, 17, 16, 15, 14, 13, 12, 11	B ₀ to B ₇	data inputs/outputs
19	\overline{OE}	output enable input (active LOW)
20	V _{CC}	positive supply voltage

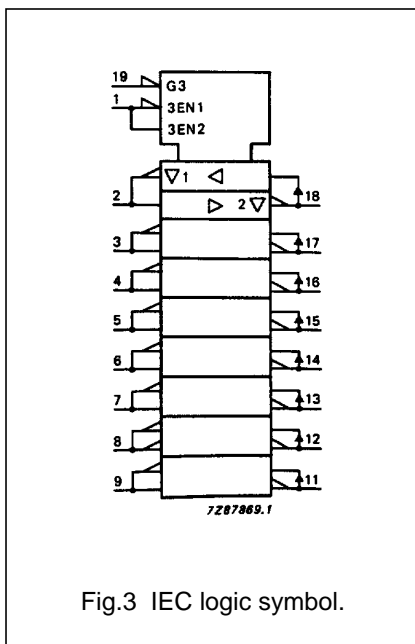
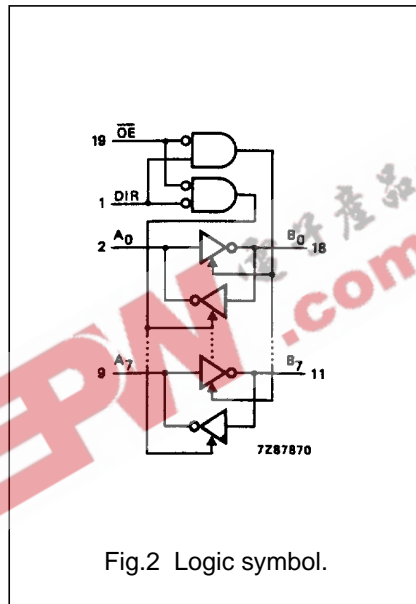
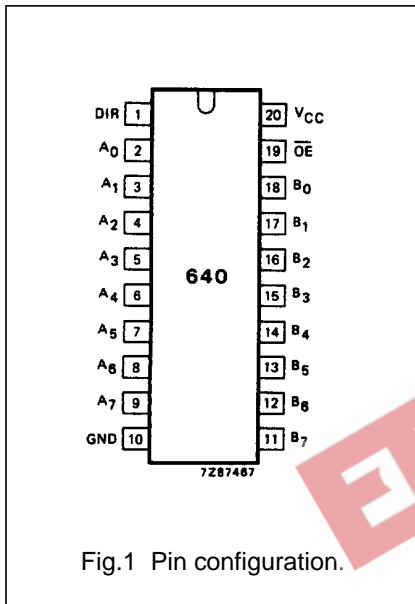

FUNCTION TABLE

inputs		inputs/outputs	
\overline{OE}	DIR	A _n	B _n
L	L	A = \overline{B}	inputs
L	H	inputs	B = \overline{A}
H	X	Z	Z

Note

- H = HIGH voltage level
L = LOW voltage level
X = don't care
Z = high impedance OFF-state

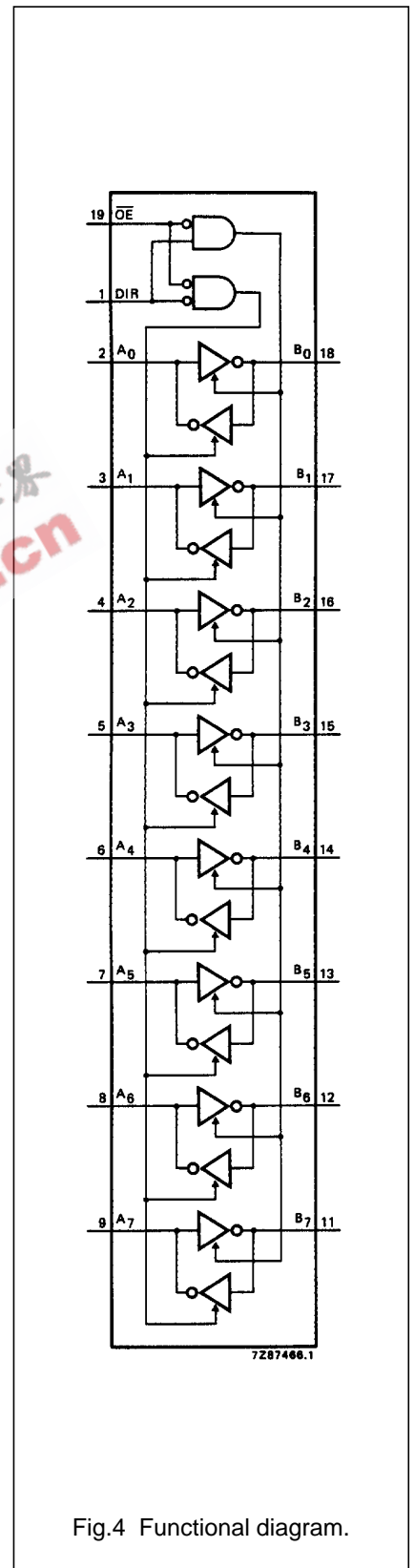

Octal bus transceiver; 3-state; inverting

74HC/HCT640

DC CHARACTERISTICS FOR 74HC

For the DC characteristics see *"74HC/HCT/HCU/HCMOS Logic Family Specifications"*.

Output capability: bus driver

I_{CC} category: MSI

AC CHARACTERISTICS FOR 74HC

GND = 0 V; t_r = t_f = 6 ns; C_L = 50 pF

SYMBOL	PARAMETER	T _{amb} (°C)						UNIT	TEST CONDITIONS		
		74HC							V _{CC} (V)	WAVEFORMS	
		+25			-40 to +85		-40 to +125				
		min.	typ.	max.	min.	max.	min.				max.
t _{PHL} / t _{PLH}	propagation delay A _n to B _n ; B _n to A _n		30 11 9	90 18 15		115 23 20	135 27 23	ns	2.0 4.5 6.0	Fig.5	
t _{PZH} / t _{PZL}	3-state output enable time \overline{OE} , DIR to A _n ; \overline{OE} , DIR to B _n		44 16 13	150 30 26		190 38 33	225 45 38	ns	2.0 4.5 6.0	Fig.6	
t _{PHZ} / t _{PLZ}	3-state output disable time \overline{OE} , DIR to A _n ; \overline{OE} , DIR to B _n		50 18 14	150 30 26		190 38 33	225 45 38	ns	2.0 4.5 6.0	Fig.6	
t _{THL} / t _{TLH}	output transition time		14 5 4	60 12 10		75 15 13	90 18 15	ns	2.0 4.5 6.0	Fig.5	

Octal bus transceiver; 3-state; inverting

74HC/HCT640

DC CHARACTERISTICS FOR 74HCT

For the DC characteristics see *"74HC/HCT/HCU/HCMOS Logic Family Specifications"*.

Output capability: bus driver

I_{CC} category: MSI

Note to HCT types

The value of additional quiescent supply current (ΔI_{CC}) for a unit load of 1 is given in the family specifications. To determine ΔI_{CC} per input, multiply this value by the unit load coefficient shown in the table below.

INPUT	UNIT LOAD COEFFICIENT
A _n	1.50
B _n	1.50
\overline{OE}	1.50
DIR	0.90

AC CHARACTERISTICS FOR 74HCT

GND = 0 V; t_r = t_f = 6 ns; C_L = 50 pF

SYMBOL	PARAMETER	T _{amb} (°C)						UNIT	TEST CONDITIONS		
		74HCT							V _{CC} (V)	WAVEFORMS	
		+25			-40 to +85		-40 to +125				
		min.	typ.	max.	min.	max.	min.				max.
t _{PHL} / t _{PLH}	propagation delay A _n to B _n ; B _n to A _n		11	22		28		33	ns	4.5	Fig.5
t _{PZH} / t _{PZL}	3-state output enable time \overline{OE} , DIR to A _n ; \overline{OE} , DIR to B _n		18	30		38		45	ns	4.5	Fig.6
t _{PHZ} / t _{PLZ}	3-state output disable time \overline{OE} , DIR to A _n ; \overline{OE} , DIR to B _n		19	30		38		45	ns	4.5	Fig.6
t _{THL} / t _{TLH}	output transition time		5	12		15		18	ns	4.5	Fig.5

Octal bus transceiver; 3-state; inverting

74HC/HCT640

AC WAVEFORMS

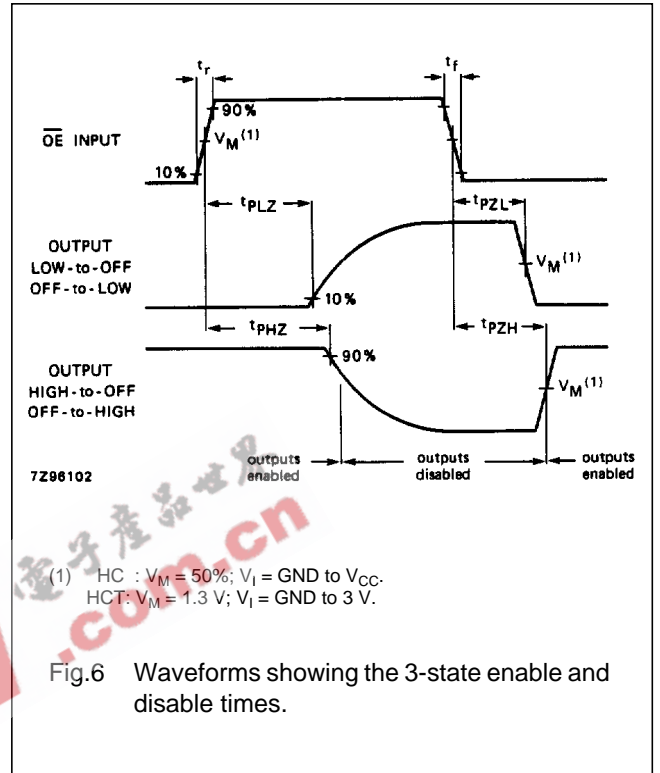
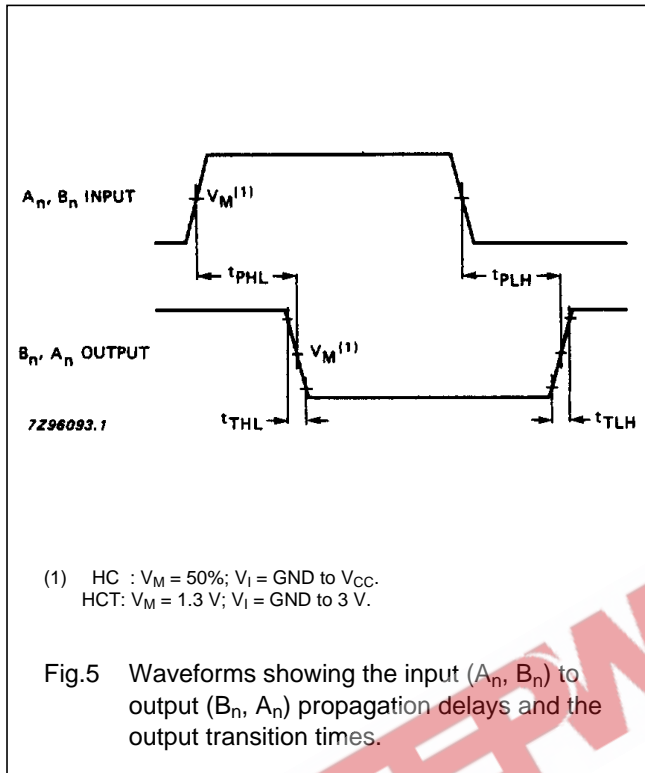

PACKAGE OUTLINES

See "74HC/HCT/HCU/HCMOS Logic Package Outlines".