

DATA SHEET

74ABT16825A

74ABTH16825A

18-bit buffer/line driver; non-inverting
(3-State)

EEPW 电子产品世界
.com.cn

Product specification
Supersedes data of 1995 Jul 14
IC23 Data Handbook

1998 Feb 25

18-bit buffer/line driver; non-inverting (3-State)**74ABT16825A**
74ABTH16825A**FEATURES**

- Multiple V_{CC} and GND pins minimize switching noise
- Live insertion/extraction permitted
- 3-State output buffers
- Power-up 3-State
- 74ABTH16825A incorporates bus-hold data inputs which eliminate the need for external pull-up resistors to hold unused inputs
- Output capability: +64mA/-32mA
- Latch-up protection exceeds 500mA per Jedec Std 17
- ESD protection exceeds 2000V per MIL STD 883 Method 3015 and 200V per Machine Model
- Bus-hold data inputs eliminate the need for external pull-up resistors to hold unused inputs

DESCRIPTION

The 74ABT16825A high-performance BiCMOS device combines low static and dynamic power dissipation with high speed and high output drive.

The 74ABT16825A 18-bit buffers provide high performance bus interface buffering for wide data/address paths or buses carrying parity. They have NOR Output Enables ($n\overline{OE}1$, $n\overline{OE}2$) for maximum control flexibility.

Two options are available, 74ABT16825A which does not have the bus-hold feature and 74ABTH16825A which incorporates the bus-hold feature.

QUICK REFERENCE DATA

SYMBOL	PARAMETER	CONDITIONS	TYPICAL	UNIT
		$T_{amb} = 25^{\circ}\text{C}$; GND = 0V		
t_{PLH} t_{PHL}	Propagation delay nAx to nYx	$C_L = 50\text{pF}$; $V_{CC} = 5\text{V}$	1.8 1.4	ns
C_{IN}	Input capacitance	$V_I = 0\text{V}$ or V_{CC}	4	pF
C_{OUT}	Output capacitance	$V_O = 0\text{V}$ or V_{CC} ; 3-State	6	pF
I_{CCZ}	Quiescent supply current	Outputs disabled; $V_{CC} = 5.5\text{V}$	500	μA
I_{CCL}		Outputs Low; $V_{CC} = 5.5\text{V}$	9	mA

ORDERING INFORMATION

PACKAGES	TEMPERATURE RANGE	OUTSIDE NORTH AMERICA	NORTH AMERICA	DWG NUMBER
56-pin SSOP Type III	-40°C to +85°C	74ABT16825A DL	BT16825A DL	SOT371-1
56-pin TSSOP Type II	-40°C to +85°C	74ABT16825A DGG	BT16825A DGG	SOT364-1
56-pin SSOP Type III	-40°C to +85°C	74ABTH16825A DL	BH16825A DL	SOT371-1
56-pin TSSOP Type II	-40°C to +85°C	74ABTH16825A DGG	BH16825A DGG	SOT364-1

PIN DESCRIPTION

PIN NUMBER	SYMBOL	FUNCTION
55, 54, 52, 51, 49, 48, 47, 45, 44, 41, 40, 38, 37, 36, 34, 33, 31, 30	1A0 – 1A9 2A0 – 2A9	Data inputs
2, 3, 5, 6, 8, 9, 10, 12, 13 16, 17, 19, 20, 21, 23, 24, 26, 27	1Y0 – 1Y9 2Y0 – 2Y9	Data outputs
1, 56 28, 29	1OE0, 1OE1 2OE0, 2OE1	Output enable inputs (active-Low)
4, 11, 14, 15, 18, 25, 32, 39, 42, 43, 46, 53	GND	Ground (0V)
7, 22, 35, 50	V_{CC}	Positive supply voltage

18-bit buffer/line driver; non-inverting (3-State)

74ABT16825A
74ABTH16825A

PIN CONFIGURATION

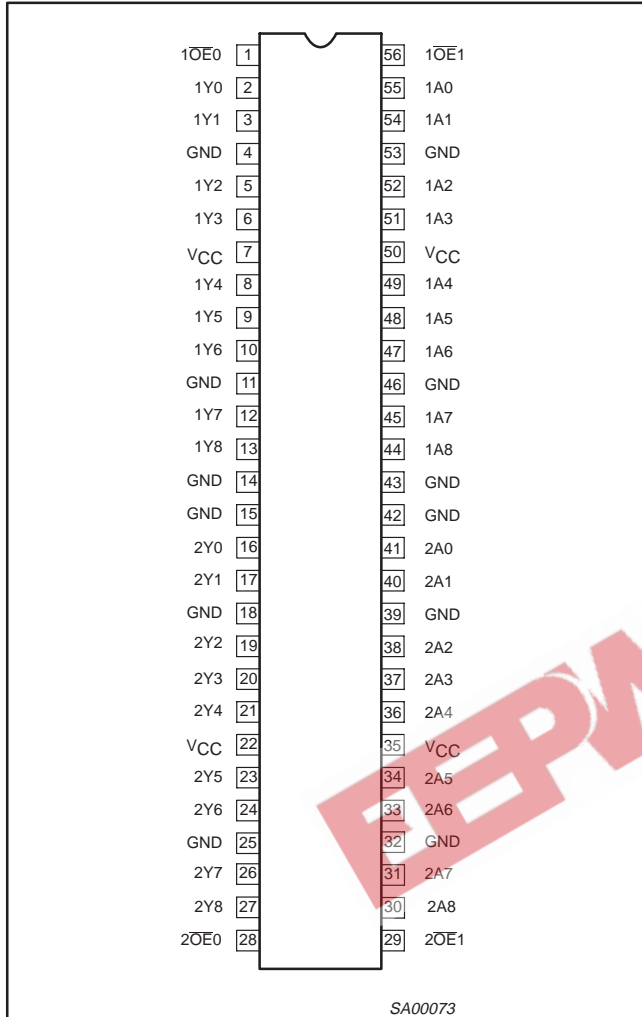

LOGIC SYMBOL (IEEE/IEC)

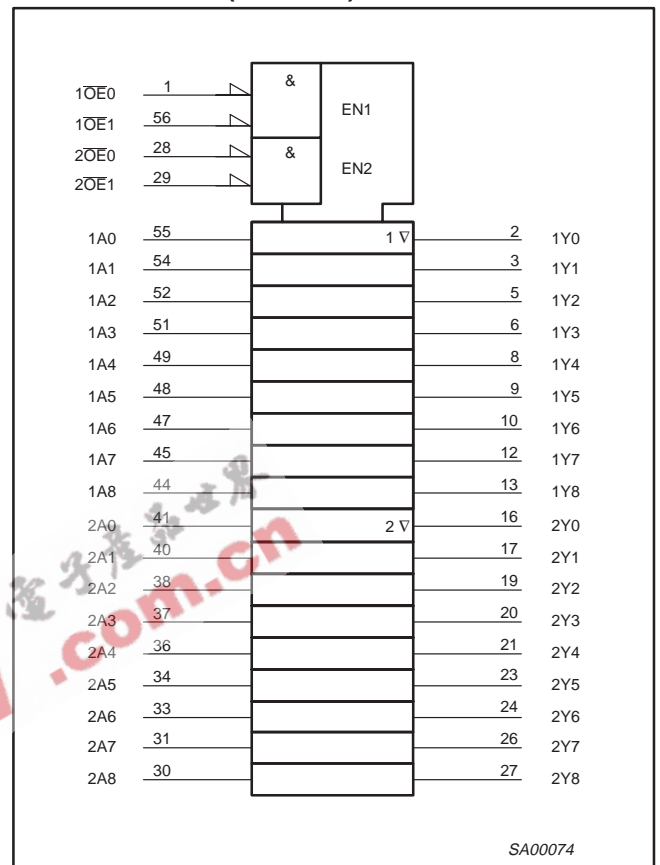

LOGIC DIAGRAM

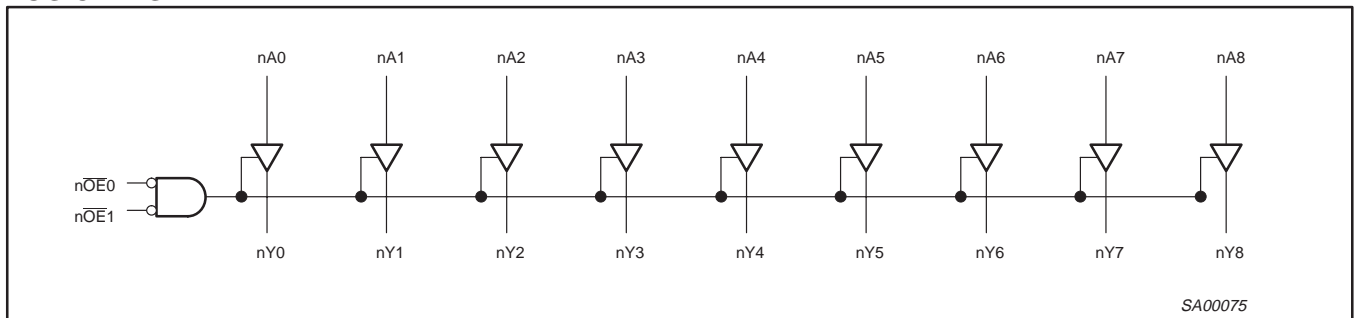

18-bit buffer/line driver; non-inverting (3-State)

74ABT16825A
74ABTH16825A

FUNCTION TABLE

INPUTS		OUTPUTS	OPERATING MODE
nOE _x	nAx	nY _x	
L	L	L	Transparent
L	H	H	Transparent
H	X	Z	High impedance

H = High voltage level
L = Low voltage level
X = Don't care
Z = High impedance "off" state

LOGIC SYMBOL

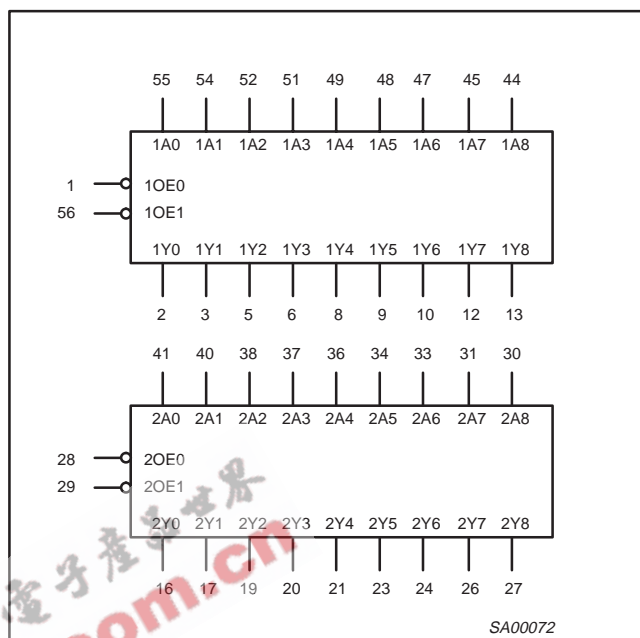
ABSOLUTE MAXIMUM RATINGS^{1, 2}

SYMBOL	PARAMETER	CONDITIONS	RATING	UNIT
V _{CC}	DC supply voltage		-0.5 to +7.0	V
I _{IK}	DC input diode current	V _I < 0	-18	mA
V _I	DC input voltage ³		-1.2 to +7.0	V
I _{OK}	DC output diode current	V _O < 0	-50	mA
V _{OUT}	DC output voltage ³	Output in Off or High state	-0.5 to +5.5	V
I _{OUT}	DC output current	Output in Low state	128	mA
		Output in High state	-64	
T _{stg}	Storage temperature range		-65 to 150	°C

NOTES:

- Stresses beyond those listed may cause permanent damage to the device. These are stress ratings only and functional operation of the device at these or any other conditions beyond those indicated under "recommended operating conditions" is not implied. Exposure to absolute-maximum-rated conditions for extended periods may affect device reliability.
- The performance capability of a high-performance integrated circuit in conjunction with its thermal environment can create junction temperatures which are detrimental to reliability. The maximum junction temperature of this integrated circuit should not exceed 150°C.
- The input and output voltage ratings may be exceeded if the input and output current ratings are observed.

RECOMMENDED OPERATING CONDITIONS

SYMBOL	PARAMETER	LIMITS		UNIT
		MIN	MAX	
V _{CC}	DC supply voltage	4.5	5.5	V
V _I	Input voltage	0	V _{CC}	V
V _{IH}	High-level input voltage	2.0		V
V _{IL}	Low-level Input voltage		0.8	V
I _{OH}	High-level output current		-32	mA
I _{OL}	Low-level output current		64	mA
Δt/Δv	Input transition rise or fall rate	0	10	ns/V
T _{amb}	Operating free-air temperature range	-40	+85	°C

18-bit buffer/line driver; non-inverting (3-State)

74ABT16825A
74ABTH16825A

DC ELECTRICAL CHARACTERISTICS

SYMBOL	PARAMETER	TEST CONDITIONS	LIMITS					UNIT
			T _{amb} = +25°C			T _{amb} = -40°C to +85°C		
			MIN	TYP	MAX	MIN	MAX	
V _{IK}	Input clamp voltage	V _{CC} = 4.5V; I _{IK} = -18mA		-0.9	-1.2		-1.2	V
V _{OH}	High-level output voltage	V _{CC} = 4.5V; I _{OH} = -3mA; V _I = V _{IL} or V _{IH}	2.5	2.9		2.5		V
		V _{CC} = 5.0V; I _{OH} = -3mA; V _I = V _{IL} or V _{IH}	3.0	3.4		3.0		V
		V _{CC} = 4.5V; I _{OH} = -32mA; V _I = V _{IL} or V _{IH}	2.0	2.4		2.0		V
V _{OL}	Low-level output voltage	V _{CC} = 4.5V; I _{OL} = 64mA; V _I = V _{IL} or V _{IH}		0.42	0.55		0.55	V
I _I	Input leakage current ABT16825A	V _{CC} = 5.5V; V _I = GND or 5.5V		±0.01	±1.0		±1.0	µA
I _I	Input leakage current 74ABTH16825A	V _{CC} = 5.5V; V _I = V _{CC} or GND		±0.01	±1		±1	µA
		V _{CC} = 5.5V; V _I = V _{CC}		0.01	1		1	µA
		V _{CC} = 5.5V; V _I = 0		-1	-3		-5	µA
I _{HOLD}	Bus Hold current A inputs ⁵ 74ABTH16825A	V _{CC} = 4.5V; V _I = 0.8V	35			35		µA
		V _{CC} = 4.5V; V _I = 2.0V	-75			-75		
		V _{CC} = 5.5V; V _I = 0 to 5.5V	±500					
I _{OFF}	Power-off leakage current	V _{CC} = 0.0V; V _O = 4.5V; V _I = 0V or 5.5V		±5.0	±100		±100	µA
I _{PU} /I _{PD}	Power-up/down 3-State output current ³	V _{CC} = 2.1V; V _O = 0.5V; V _I = GND or V _{CC} ; V _{OE} = Don't care		±5.0	±50		±50	µA
I _{OZH}	3-State output High current	V _{CC} = 5.5V; V _O = 5.5V; V _I = V _{IL} or V _{IH}		1.0	10		10	µA
I _{OZL}	3-State output Low current	V _{CC} = 5.5V; V _O = 0.0V; V _I = V _{IL} or V _{IH}		-1.0	-10		-10	µA
I _{CEX}	Output High leakage current	V _{CC} = 5.5V; V _O = 5.5V; V _I = GND or V _{CC}		1.0	50		50	µA
I _O	Output current ¹	V _{CC} = 5.5V; V _O = 2.5V	-50	-70	-180	-50	-180	mA
I _{CCH}	Quiescent supply current	V _{CC} = 5.5V; Outputs High, V _I = GND or V _{CC}		0.5	1		1	mA
I _{CCL}		V _{CC} = 5.5V; Outputs Low, V _I = GND or V _{CC}		9	19		19	mA
I _{CCZ}		V _{CC} = 5.5V; Outputs 3-State; V _I = GND or V _{CC}		0.5	1		1	mA
ΔI _{CC}	Additional supply current per input pin ² 74ABT16825A	V _{CC} = 5.5V; one input at 3.4V, other inputs at V _{CC} or GND		10	500		500	µA
ΔI _{CC}	Additional supply current per input pin ² 74ABTH16825A	V _{CC} = 5.5V; one input at 3.4V, other inputs at V _{CC} or GND		0.2	1		1	mA

NOTES:

- Not more than one output should be tested at a time, and the duration of the test should not exceed one second.
- This is the increase in supply current for each input at 3.4V.
- This parameter is valid for any V_{CC} between 0V and 2.1V with a transition time of up to 10msec. From V_{CC} = 2.1V to V_{CC} = 5V ± 10% a transition time of up to 100µsec is permitted.
- Unused pins at V_{CC} or GND.
- This is the bus hold overdrive current required to force the input to the opposite logic state.

AC CHARACTERISTICS

GND = 0V, t_R = t_F = 2.5ns, C_L = 50pF, R_L = 500Ω

SYMBOL	PARAMETER	WAVEFORM	LIMITS					UNIT
			T _{amb} = +25°C V _{CC} = +5.0V			T _{amb} = -40 to +85°C V _{CC} = +5.0V ±0.5V		
			MIN	TYP	MAX	MIN	MAX	
t _{PLH} t _{PHL}	Propagation delay nAx to nYx	1	1.0 0.6	1.8 1.4	2.5 2.0	1.0 0.6	2.8 2.3	ns
t _{PZH} t _{PZL}	Output enable time to High and Low level	2	1.0 1.0	2.9 2.9	3.8 3.8	1.0 1.0	4.8 5.0	ns
t _{PHZ} t _{PLZ}	Output disable time from High and Low level	2	2.0 1.6	3.3 2.5	4.5 3.4	2.0 1.6	5.2 3.7	ns

18-bit buffer/line driver; non-inverting (3-State)

74ABT16825A
74ABTH16825A

AC WAVEFORMS

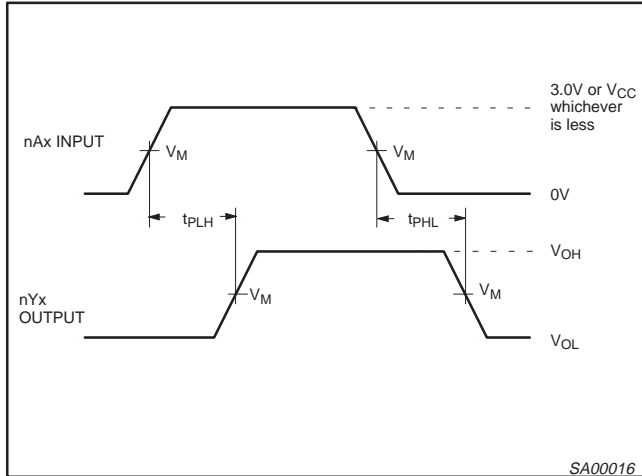

Waveform 1. Input (nAx) to Output (nYx) Propagation Delays

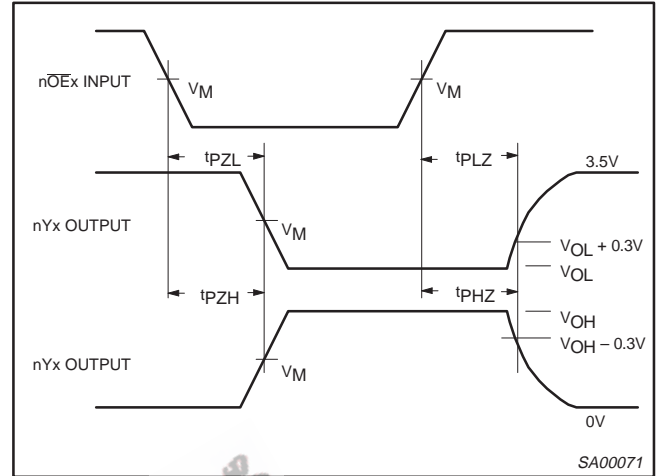

Waveform 2. 3-State Output Enable and Disable Times

TEST CIRCUIT AND WAVEFORM

Test Circuit for 3-State Outputs

SWITCH POSITION	
TEST	SWITCH
t_{PLZ}	closed
t_{PZL}	closed
All other	open

DEFINITIONS
 R_L = Load resistor; see AC CHARACTERISTICS for value.
 C_L = Load capacitance includes jig and probe capacitance; see AC CHARACTERISTICS for value.
 R_T = Termination resistance should be equal to Z_{OUT} of pulse generators.

Input Pulse Definition

$V_M = 1.5V$

FAMILY	INPUT PULSE REQUIREMENTS				
	Amplitude	Rep. Rate	t_w	t_R	t_F
74ABT/H16	3.0V	1MHz	500ns	2.5ns	2.5ns

SA00018

18-bit buffer/line driver; non-inverting (3-State)

74ABT16825A
74ABTH16825A

SSOP56: plastic shrink small outline package; 56 leads; body width 7.5 mm

SOT371-1

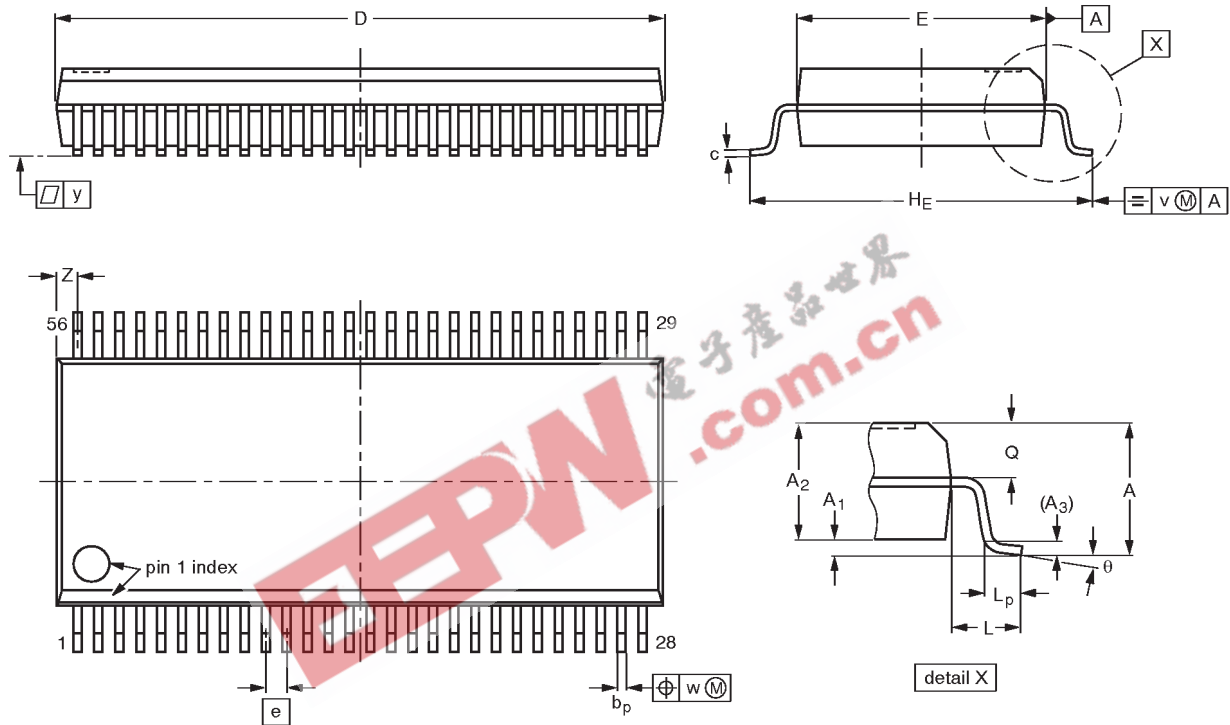

DIMENSIONS (mm are the original dimensions)

UNIT	A max.	A ₁	A ₂	A ₃	b _p	c	D ⁽¹⁾	E ⁽¹⁾	e	H _E	L	L _p	Q	v	w	y	Z ⁽¹⁾	θ
mm	2.8	0.4 0.2	2.35 2.20	0.25	0.3 0.2	0.22 0.13	18.55 18.30	7.6 7.4	0.635	10.4 10.1	1.4	1.0 0.6	1.2 1.0	0.25	0.18	0.1	0.85 0.40	8° 0°

Note

1. Plastic or metal protrusions of 0.25 mm maximum per side are not included.

OUTLINE VERSION	REFERENCES				EUROPEAN PROJECTION	ISSUE DATE
	IEC	JEDEC	EIAJ			
SOT371-1		MO-118AB				93-11-02 95-02-04

18-bit buffer/line driver; non-inverting (3-State)

74ABT16825A
74ABTH16825A

TSSOP56: plastic thin shrink small outline package; 56 leads; body width 6.1mm

SOT364-1

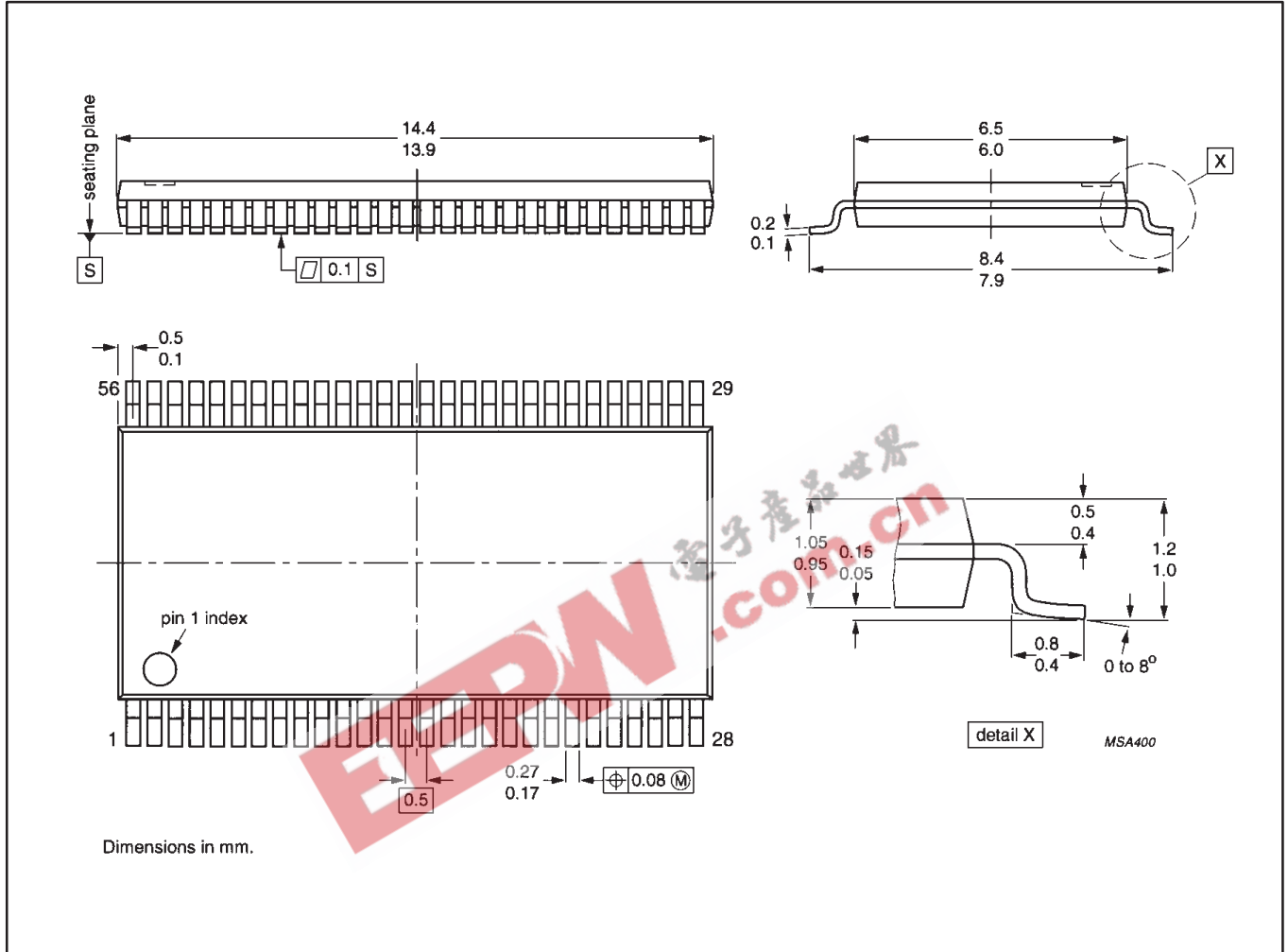

18-bit buffer/line driver; non-inverting (3-State)

74ABT16825A
74ABTH16825A

NOTES



18-bit buffer/line driver; non-inverting (3-State)

74ABT16825A
74ABTH16825A

Data sheet status

Data sheet status	Product status	Definition [1]
Objective specification	Development	This data sheet contains the design target or goal specifications for product development. Specification may change in any manner without notice.
Preliminary specification	Qualification	This data sheet contains preliminary data, and supplementary data will be published at a later date. Philips Semiconductors reserves the right to make changes at any time without notice in order to improve design and supply the best possible product.
Product specification	Production	This data sheet contains final specifications. Philips Semiconductors reserves the right to make changes at any time without notice in order to improve design and supply the best possible product.

[1] Please consult the most recently issued datasheet before initiating or completing a design.

Definitions

Short-form specification — The data in a short-form specification is extracted from a full data sheet with the same type number and title. For detailed information see the relevant data sheet or data handbook.

Limiting values definition — Limiting values given are in accordance with the Absolute Maximum Rating System (IEC 134). Stress above one or more of the limiting values may cause permanent damage to the device. These are stress ratings only and operation of the device at these or at any other conditions above those given in the Characteristics sections of the specification is not implied. Exposure to limiting values for extended periods may affect device reliability.

Application information — Applications that are described herein for any of these products are for illustrative purposes only. Philips Semiconductors make no representation or warranty that such applications will be suitable for the specified use without further testing or modification.

Disclaimers

Life support — These products are not designed for use in life support appliances, devices or systems where malfunction of these products can reasonably be expected to result in personal injury. Philips Semiconductors customers using or selling these products for use in such applications do so at their own risk and agree to fully indemnify Philips Semiconductors for any damages resulting from such application.

Right to make changes — Philips Semiconductors reserves the right to make changes, without notice, in the products, including circuits, standard cells, and/or software, described or contained herein in order to improve design and/or performance. Philips Semiconductors assumes no responsibility or liability for the use of any of these products, conveys no license or title under any patent, copyright, or mask work right to these products, and makes no representations or warranties that these products are free from patent, copyright, or mask work right infringement, unless otherwise specified.

Philips Semiconductors
811 East Arques Avenue
P.O. Box 3409
Sunnyvale, California 94088-3409
Telephone 800-234-7381

© Copyright Philips Electronics North America Corporation 1998
All rights reserved. Printed in U.S.A.

print code

Date of release: 05-96

Document order number:

9397-750-03503

Let's make things better.