

74F640 • 74F645 Octal Bus Transceiver with 3-STATE Outputs

General Description

These devices are octal bus transceivers designed for asynchronous two-way data flow between the A and B buses. Both busses are capable of sinking 64 mA, have 3-STATE outputs, and a common output enable pin. The direction of data flow is determined by the transmit/receive (T/R) input. The 74F645 is a high speed/low power version of the 74F245. The 74F640 is an inverting option of the 74F645.

Features

- Designed for asynchronous two-way data flow between busses
- Outputs sink 64 mA
- Transmit/receive (T/R) input controls the direction of data flow
- 74F645 is a lower power, faster version of the 74F245
- 74F640 is an inverting option of the 74F645

Ordering Code:

Order Number	Package Number	Package Description
74F640SC	M20B	20-Lead Small Outline Integrated Circuit (SOIC), JEDEC MS-013, 0.300 Wide
74F640PC	N20A	20-Lead Plastic Dual-In-Line Package (PDIP), JEDEC MS-001, 0.300 Wide
74F645PC	N20A	20-Lead Plastic Dual-In-Line Package (PDIP), JEDEC MS-001, 0.300 Wide

Devices also available in Tape and Reel. Specify by appending the suffix letter "X" to the ordering code.

Logic Symbol

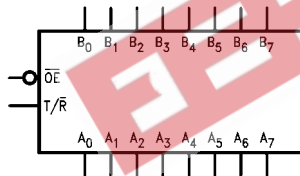

Connection Diagram

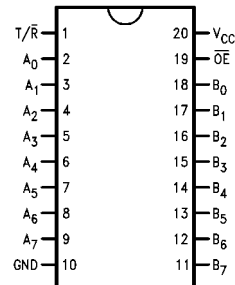

Unit Loading/Fan Out

Pin Names	Description	U.L. HIGH/LOW	Input I_{IH}/I_{IL} Output I_{OH}/I_{OL}
\overline{OE}	Output Enable Input (Active LOW)	1.0/1.0	20 μA / -0.6 mA
T/\overline{R}	Transmit/Receive Input	1.0/1.0	20 μA / -0.6 mA
A_0 - A_7	Side A Inputs or 3-STATE Outputs	3.5/0.667 600/106.6	70 μA / -0.4 mA -12 mA / 64 mA
B_0 - B_7	Side B Inputs or 3-STATE Outputs	3.5/0.667 600/106.6	70 μA / -0.4 mA -12 mA / 64 mA

Functional Description

The output enable (\overline{OE}) is active LOW. If the device is disabled (\overline{OE} HIGH), the outputs are in the high impedance state. The transmit/receive input (T/\overline{R}) controls whether data is transmitted from the A bus to the B bus or from the B bus to the A bus. When T/\overline{R} is LOW, B data is sent to the A bus. If T/\overline{R} is HIGH, A data is sent to the B bus.

Function Table

Inputs		Outputs	
\overline{OE}	T/\overline{R}	74F640	74F645
L	L	Bus \overline{B} data to Bus A	Bus B data to Bus A
L	H	Bus \overline{A} data to Bus B	Bus A data to Bus B
H	X	Z	Z

H = HIGH Voltage Level
L = LOW Voltage Level
X = Don't Care
Z = High Impedance State

Logic Diagram

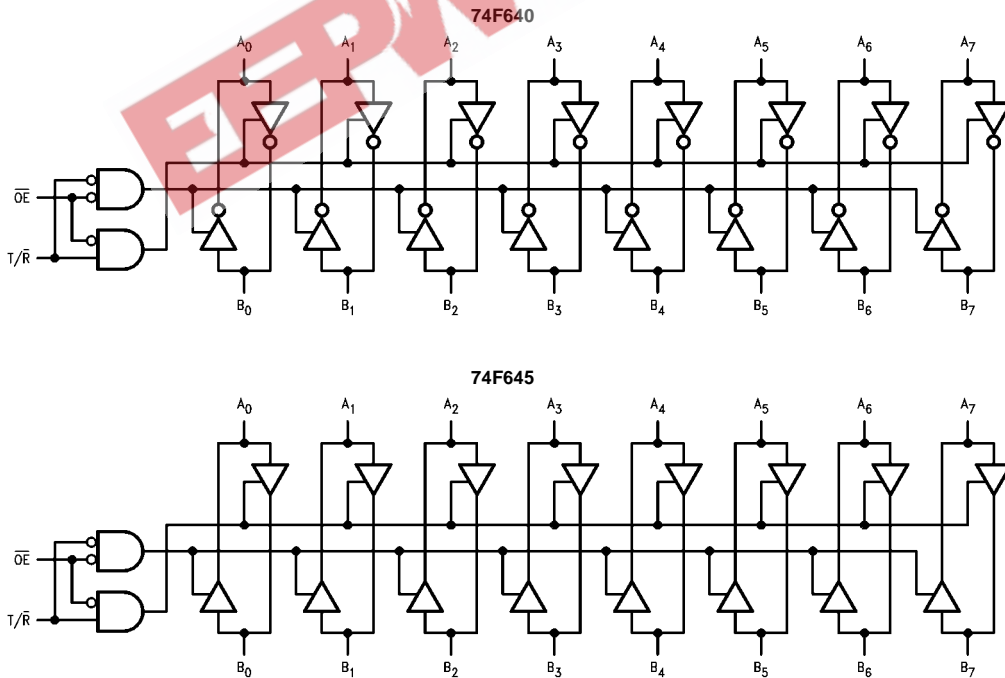

Absolute Maximum Ratings (Note 1)

Storage Temperature	-65°C to +150°C
Ambient Temperature under Bias	-55°C to +125°C
Junction Temperature under Bias	-55°C to +150°C
V _{CC} Pin Potential to Ground Pin	-0.5V to +7.0V
Input Voltage (Note 2)	-0.5V to +7.0V
Input Current (Note 2)	-30 mA to +5.0 mA
Voltage Applied to Output in HIGH State (with V _{CC} = 0V)	
Standard Output	-0.5V to V _{CC}
3-STATE Output	-0.5V to +5.5V
Current Applied to Output in LOW State (Max)	twice the rated I _{OL} (mA)
ESD Last Passing Voltage (Min)	4000V

Recommended Operating Conditions

Free Air Ambient Temperature	0°C to +70°C
Supply Voltage	+4.5V to +5.5V

Note 1: Absolute maximum ratings are values beyond which the device may be damaged or have its useful life impaired. Functional operation under these conditions is not implied.

Note 2: Either voltage limit or current limit is sufficient to protect inputs.

DC Electrical Characteristics

Symbol	Parameter	Min	Typ	Max	Units	V _{CC}	Conditions
V _{IH}	Input HIGH Voltage	2.0			V		Recognized as a HIGH Signal
V _{IL}	Input LOW Voltage			0.8	V		Recognized as a LOW Signal
V _{CD}	Input Clamp Diode Voltage			-1.2	V	Min	I _{IN} = -18 mA (Non I/O Pins)
V _{OH}	Output HIGH Voltage 10% V _{CC}	2.0			V	Min	I _{OH} = -15 mA (A _n , B _n)
V _{OL}	Output LOW Voltage 10% V _{CC}			0.55	V	Min	I _{OL} = 64 mA (A _n , B _n)
I _{IH}	Input HIGH Current			5.0	μA	Max	V _{IN} = 2.7V (Non I/O Pins)
I _{BVI}	Input HIGH Current Breakdown Test			7.0	μA	Max	V _{IN} = 7.0V (Non I/O Pins)
I _{BVIT}	Input HIGH Current Breakdown (I/O)			0.5	mA	Max	V _{IN} = 5.5V (A _n , B _n)
I _{CEx}	Output HIGH Leakage Current			50	μA	Max	V _{OUT} = V _{CC}
V _{ID}	Input Leakage Test	4.75			V	0.0	I _{ID} = 1.9 μA All Other Pins Grounded
I _{OD}	Output Leakage Circuit Current			3.75	μA	0.0	V _{IOD} = 150 mV All Other Pins Grounded
I _{IL}	Input LOW Current			-0.6	mA	Max	V _{IN} = 0.5V (Non I/O Pins)
I _{IH} + I _{OZH}	Output Leakage Current			70	μA	Max	V _{OUT} = 2.7V (A _n , B _n)
I _{IL} + I _{OZL}	Output Leakage Current			-650	μA	Max	V _{OUT} = 0.5V (A _n , B _n)
I _{OS}	Output Short-Circuit Current	-100		-225	mA	Max	V _{OUT} = 0V
I _{ZZ}	Bus Drainage Test			500	μA	0.0V	V _{OUT} = 5.25
I _{CCH}	Power Supply Current (74F640)			80	mA	Max	V _O = HIGH, V _{IN} = 0.2V
I _{CCL}	Power Supply Current (74F640)			80	mA	Max	V _O = LOW
I _{CCZ}	Power Supply Current (74F640)			96	mA	Max	V _O = HIGH Z
I _{CCH}	Power Supply Current (74F645)			65	mA	Max	V _O = HIGH
I _{CCL}	Power Supply Current (74F645)			80	mA	Max	V _O = LOW, V _{IN} = 0.2V
I _{CCZ}	Power Supply Current (74F645)			90	mA	Max	V _O = HIGH Z

AC Electrical Characteristics 74F640							
Symbol	Parameter	T _A = +25°C V _{CC} = +5.0V C _L = 50 pF			T _A = 0°C to +70°C V _{CC} = +5.0V C _L = 50 pF		Units
		Min	Typ	Max	Min	Max	
t _{PLH}	Propagation Delay	2.5		7.5	2.0	8.0	ns
t _{PHL}	A Input to B Output	2.0		7.0	2.0	7.0	
t _{PLH}	Propagation Delay	2.5		7.5	2.0	8.0	ns
t _{PHL}	B Input to A Output	2.0		7.0	2.0	7.0	
t _{PZH}	Enable Time	2.5		7.5	2.0	9.0	ns
t _{PZL}	$\overline{\text{OE}}$ Input to A Output	2.5		8.0	2.0	8.5	
t _{PHZ}	Disable Time	1.5		7.0	1.0	7.5	ns
t _{PLZ}	$\overline{\text{OE}}$ Input to A Output	1.5		6.0	1.5	6.0	
t _{PZH}	Enable Time	2.5		7.5	2.0	9.0	ns
t _{PZL}	$\overline{\text{OE}}$ Input to B Output	2.5		8.0	2.0	8.5	
t _{PHZ}	Disable Time	1.5		7.0	1.0	7.5	ns
t _{PLZ}	$\overline{\text{OE}}$ Input to B Output	1.5		6.0	1.5	6.0	

AC Electrical Characteristics 74F645							
Symbol	Parameter	T _A = +25°C V _{CC} = +5.0V C _L = 50 pF			T _A = 0°C to +70°C V _{CC} = +5.0V C _L = 50 pF		Units
		Min	Typ	Max	Min	Max	
t _{PLH}	Propagation Delay	1.5		6.0	1.5	7.0	ns
t _{PHL}	A Input to B Output	2.0		7.0	2.0	7.5	
t _{PLH}	Propagation Delay	1.5		6.0	1.5	7.0	ns
t _{PHL}	B Input to A Output	2.0		7.0	2.0	7.5	
t _{PZH}	Enable Time	2.5		8.0	2.0	9.0	ns
t _{PZL}	$\overline{\text{OE}}$ Input to A Output	2.5		8.5	2.0	8.5	
t _{PHZ}	Disable Time	1.5		7.0	1.0	8.0	ns
t _{PLZ}	$\overline{\text{OE}}$ Input to A Output	1.0		5.5	1.0	5.5	
t _{PZH}	Enable Time	2.5		7.5	2.0	9.5	ns
t _{PZL}	$\overline{\text{OE}}$ Input to B Output	2.5		8.5	2.5	9.0	
t _{PHZ}	Disable Time	1.5		6.5	1.0	7.5	ns
t _{PLZ}	$\overline{\text{OE}}$ Input to B Output	1.0		5.5	1.0	5.5	

Physical Dimensions inches (millimeters) unless otherwise noted

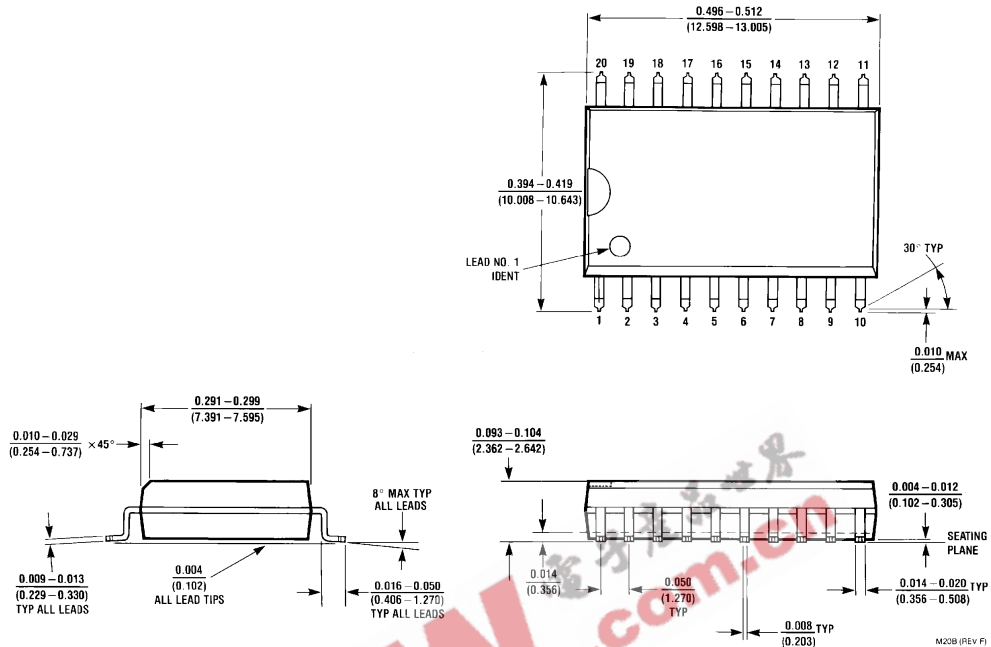

**20-Lead Small Outline Integrated Circuit (SOIC), JEDEC MS-013, 0.300 Wide
Package Number M20B**

