

OCTAL BUS TRANSCEIVER HC620 3 STATE INVERTING HC623 3 STATE NON INVERTING

- HIGH SPEED
 $t_{PD} = 10 \text{ ns (TYP.) AT } V_{CC} = 5 \text{ V}$
- LOW POWER DISSIPATION
 $I_{CC} = 4 \mu\text{A (MAX.) AT } T_A = 25^\circ\text{C}$
- HIGH NOISE IMMUNITY
 $V_{NIH} = V_{NIL} = 28\% V_{CC} \text{ (MIN.)}$
- OUTPUT DRIVE CAPABILITY
15 LSTTL LOADS
- SYMMETRICAL OUTPUT IMPEDANCE
 $|I_{OH}| = I_{OL} = 6 \text{ mA (MIN.)}$
- BALANCED PROPAGATION DELAYS
 $t_{PLH} = t_{PHL}$
- WIDE OPERATING VOLTAGE RANGE
 $V_{CC} \text{ (OPR)} = 2 \text{ V to } 6 \text{ V}$
- PIN AND FUNCTION COMPATIBLE WITH LS620/623

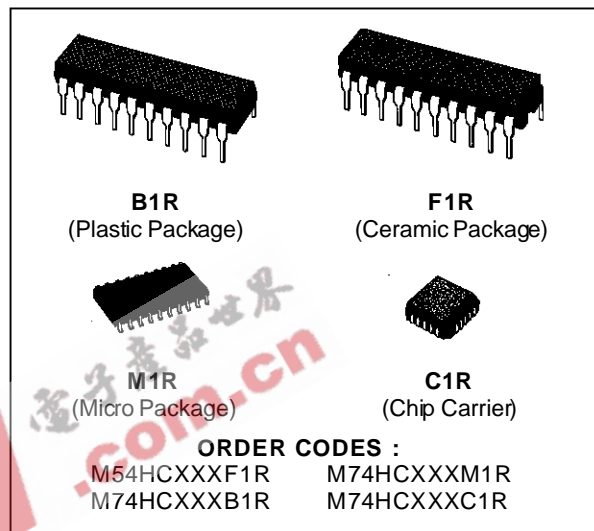

DESCRIPTION

The M54/74HC620/623 are high speed CMOS OCTAL BUS TRANSCEIVERS fabricated in silicon gate C²MOS technology. They have the same high speed performance of LSTTL combined with true CMOS low power consumption.

These octal bus transceivers are designed for asynchronous two-way communication between data buses. The control function implementation allows maximum flexibility in timing.

These devices allow data transmission from the A bus to B bus or from the B to the A bus depending upon the logic levels at the enable inputs (\overline{GBA} and GAB). The enable inputs can be used to disable the device so that the buses are effectively isolated.

The dual-enable configuration gives these devices the capability to store data by simultaneous enabling of \overline{GBA} and GAB.

Each output reinforces its input in this transceiver configuration. Thus, when both control inputs are enabled and all other data sources to the two sets of bus lines are at high impedance, both sets of bus lines (16 in all) will remain at their last states. The 8-bit codes appearing on the two sets of buses will be identical for the 'HC623 or complementary for the 'HC620. All inputs are equipped with protection circuits against static discharge and transient excess voltage.

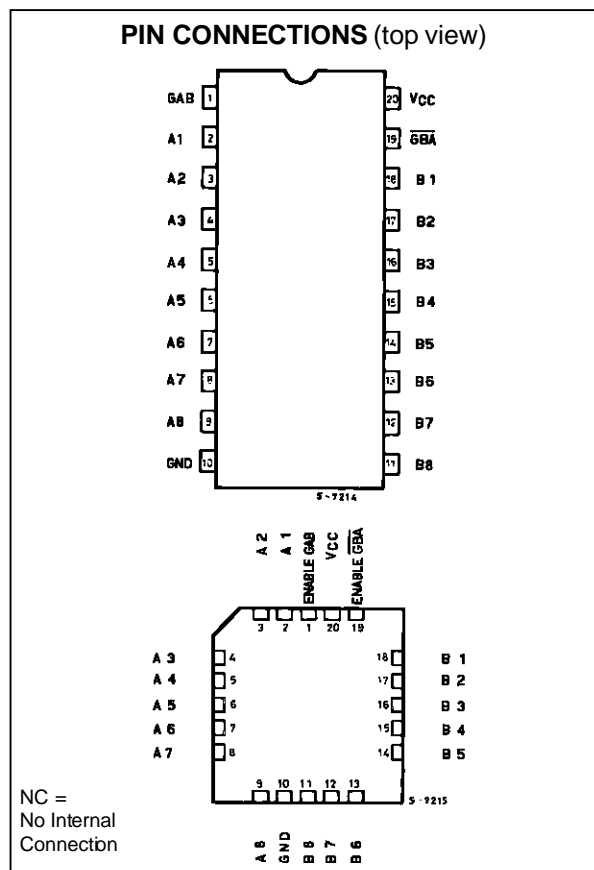

M54/M74HC620/623

INPUT AND OUTPUT EQUIVALENT CIRCUIT

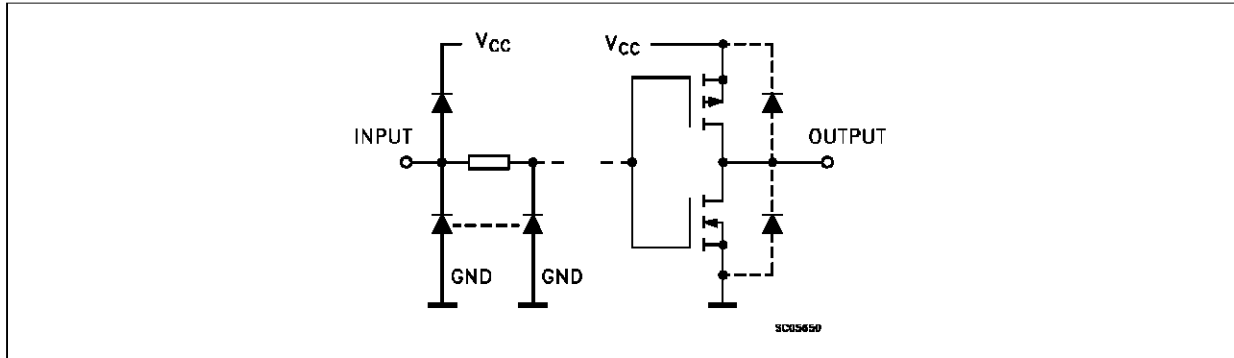

TRUTH TABLE

INPUTS		FUNCTION		OUTPUTS	
GAB	\overline{GAB}	A Bus	B Bus	HC620	HC623
L	L	Output	Input	$A = B$	$A = B$
H	H	Input	Output	$B = \overline{A}$	$B = A$
L	H	High Impedance		Z	Z
H	L	High Impedance		Z	Z

LOGIC DIAGRAM

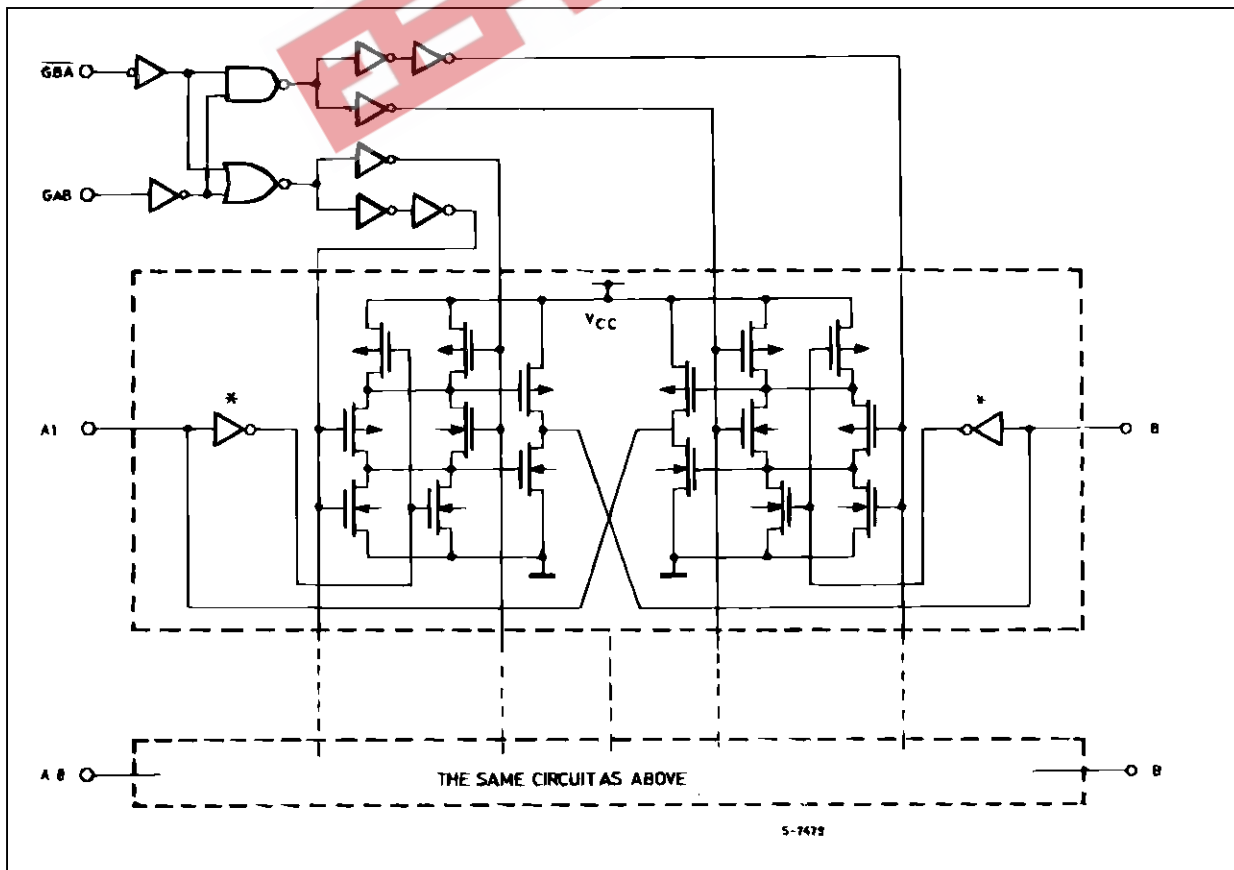

PIN DESCRIPTION

PIN No	SYMBOL	NAME AND FUNCTION
1, 19	GBA , GAB	Direction Controls
2, 3, 4, 5, 6, 7, 8, 9	A1 to A8	Data Inputs/Outputs
11, 12, 13, 14, 15, 16, 17, 18	B1 to B8	Data Inputs/Outputs
10	GND	Ground (0V)
20	V _{CC}	Positive Supply Voltage

IEC LOGIC SYMBOLS

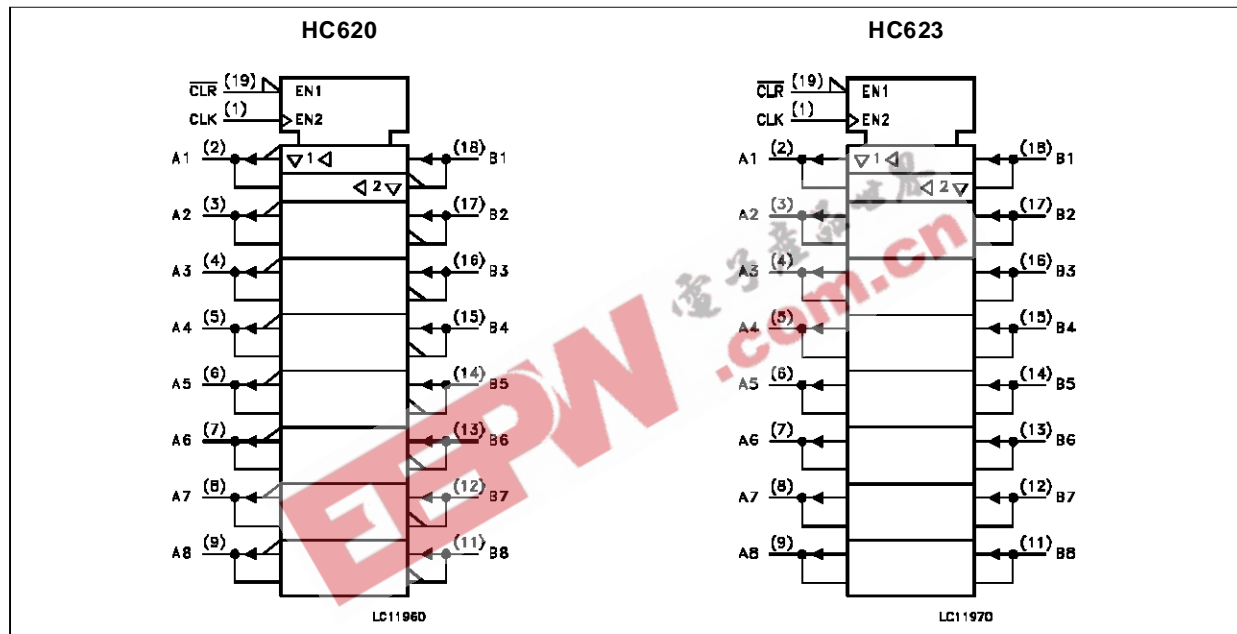

ABSOLUTE MAXIMUM RATINGS

Symbol	Parameter	Value	Unit
V _{CC}	Supply Voltage	-0.5 to +7	V
V _I	DC Input Voltage	-0.5 to V _{CC} + 0.5	V
V _O	DC Output Voltage	-0.5 to V _{CC} + 0.5	V
I _{IK}	DC Input Diode Current	± 20	mA
I _{OK}	DC Output Diode Current	± 20	mA
I _O	DC Output Source Sink Current Per Output Pin	± 35	mA
I _{CC} or I _{GND}	DC V _{CC} or Ground Current	± 70	mA
P _D	Power Dissipation	500 (*)	mW
T _{stg}	Storage Temperature	-65 to +150	°C
T _L	Lead Temperature (10 sec)	300	°C

Absolute Maximum Ratings are those values beyond which damage to the device may occur. Functional operation under these condition is not implied.

(*) 500 mW: ≅ 65 °C derate to 300 mW by 10mW/°C: 65 °C to 85 °C

M54/M74HC620/623

RECOMMENDED OPERATING CONDITIONS

Symbol	Parameter	Value	Unit
V_{CC}	Supply Voltage	2 to 6	V
V_I	Input Voltage	0 to V_{CC}	V
V_O	Output Voltage	0 to V_{CC}	V
T_{op}	Operating Temperature: M54HC Series M74HC Series	-55 to +125 -40 to +85	°C °C
t_r, t_f	Input Rise and Fall Time	$V_{CC} = 2\text{ V}$	0 to 1000
		$V_{CC} = 4.5\text{ V}$	0 to 500
		$V_{CC} = 6\text{ V}$	0 to 400

DC SPECIFICATIONS

Symbol	Parameter	Test Conditions		Value						Unit	
				$T_A = 25\text{ °C}$ 54HC and 74HC			$-40\text{ to }85\text{ °C}$ 74HC		$-55\text{ to }125\text{ °C}$ 54HC		
				Min.	Typ.	Max.	Min.	Max.	Min.		Max.
V_{IH}	High Level Input Voltage	2.0 4.5 6.0		1.5			1.5		1.5	V	
				3.15			3.15		3.15		
				4.2			4.2		4.2		
V_{IL}	Low Level Input Voltage	2.0 4.5 6.0				0.5		0.5	0.5	V	
						1.35		1.35	1.35		
						1.8		1.8	1.8		
V_{OH}	High Level Output Voltage	2.0 4.5 6.0 4.5 6.0	$V_I = V_{IH}$ or V_{IL}	$I_O = -20\text{ }\mu\text{A}$ $I_O = -6.0\text{ mA}$ $I_O = -7.8\text{ mA}$	1.9	2.0		1.9		1.9	V
					4.4	4.5		4.4		4.4	
					5.9	6.0		5.9		5.9	
					4.18	4.31		4.13		4.10	
					5.68	5.8		5.63		5.60	
V_{OL}	Low Level Output Voltage	2.0 4.5 6.0 4.5 6.0	$V_I = V_{IH}$ or V_{IL}	$I_O = 20\text{ }\mu\text{A}$ $I_O = 6.0\text{ mA}$ $I_O = 7.8\text{ mA}$		0.0	0.1		0.1	0.1	V
						0.0	0.1		0.1	0.1	
						0.0	0.1		0.1	0.1	
						0.17	0.26		0.33	0.40	
						0.18	0.26		0.33	0.40	
I_I	Input Leakage Current	6.0	$V_I = V_{CC}$ or GND			± 0.1		± 1	± 1	μA	
I_{OZ}	3 State Output Off State Current	6.0	$V_I = V_{IH}$ or V_{IL} $V_O = V_{CC}$ or GND			± 0.5		± 5	± 10	μA	
I_{CC}	Quiescent Supply Current	6.0	$V_I = V_{CC}$ or GND			4		40	80	μA	

AC ELECTRICAL CHARACTERISTICS ($C_L = 50$ pF, Input $t_r = t_f = 6$ ns)

Symbol	Parameter	Test Conditions			Value						Unit	
		V _{CC} (V)	C _L (pF)		T _A = 25 °C 54HC and 74HC			-40 to 85 °C 74HC		-55 to 125 °C 54HC		
					Min.	Typ.	Max.	Min.	Max.	Min.		Max.
t _{TLH} t _{THL}	Output Transition Time	2.0	50			25	60		75		90	ns
		4.5			7	12		15		18		
		6.0			6	10		13		15		
t _{PLH} t _{PHL}	Propagation Delay Time (for HC620)	2.0	50		41	100		125		150	ns	
		4.5			12	20		25		30		
		6.0			10	17		21		26		
		2.0	150		55	130		165		195	ns	
		4.5			16	26		33		39		
		6.0			14	22		28		33		
t _{PLH} t _{PHL}	Propagation Delay Time (for HC623)	2.0	50		38	85		105		130	ns	
		4.5			12	17		21		26		
		6.0			10	14		18		22		
		2.0	150		51	130		165		195	ns	
		4.5			16	26		33		39		
		6.0			14	22		28		33		
t _{PZL} t _{PZH}	Output Enable Time	2.0	50	R _L = 1 KΩ		57	150		190		225	ns
		4.5				19	30		38		45	
		6.0				16	26		32		38	
		2.0	150	R _L = 1 KΩ		69	180		225		270	ns
		4.5				23	36		45		54	
		0				20	31		38		46	
t _{PLZ} t _{PHZ}	Output Disable Time	2.0	50	R _L = 1 KΩ		43	125		155		190	ns
		4.5				18	25		31		38	
		6.0				15	21		26		32	
C _{IN}	Input Capacitance				5	10		10		10	pF	
C _{PD} (*)	Power Dissipation Capacitance			for HC620 for HC623	32 34						pF	

C_{PD} is defined as the value of the IC's internal equivalent capacitance which is calculated from the operating current consumption without load. (Refer to Test Circuit). Average operating current can be obtained by the following equation. $I_{CC(opr)} = C_{PD} \cdot V_{CC} \cdot f_{IN} + I_{CC}$

M54/M74HC620/623

SWITCHING CHARACTERISTICS TEST WAVEFORM

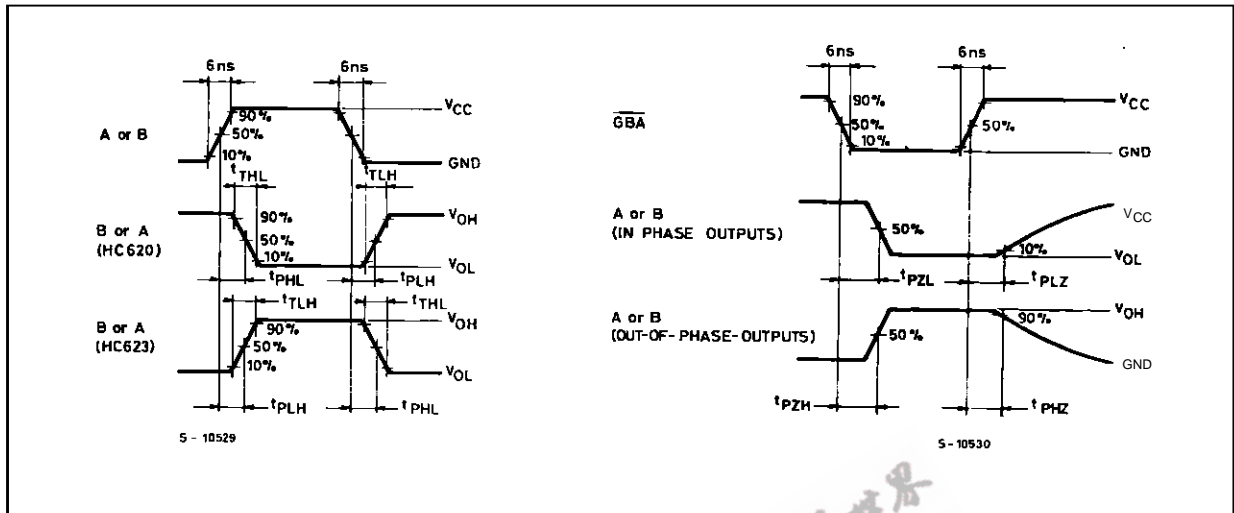

TEST CIRCUIT I_{CC} (Opr.)

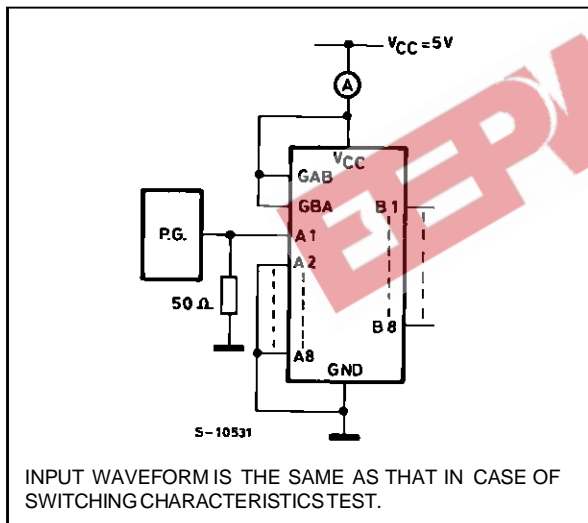

C_{PD} CALCULATION

C_{PD} is to be calculated with the following formula by using the measured value of I_{CC} (Opr.) in the test circuit opposite.

$$C_{PD} = \frac{I_{CC} (Opr.)}{f_{IN} \times V_{CC}}$$

In determining the typical value of C_{PD} , a relatively high frequency of 1 MHz was applied to f_{IN} , in order to eliminate any error caused by the quiescent supply current.

Plastic DIP20 (0.25) MECHANICAL DATA

DIM.	mm			inch		
	MIN.	TYP.	MAX.	MIN.	TYP.	MAX.
a1	0.254			0.010		
B	1.39		1.65	0.055		0.065
b		0.45			0.018	
b1		0.25			0.010	
D			25.4			1.000
E		8.5			0.335	
e		2.54			0.100	
e3		22.86			0.900	
F			7.1			0.280
I			3.93			0.155
L		3.3			0.130	
Z			1.34			0.053

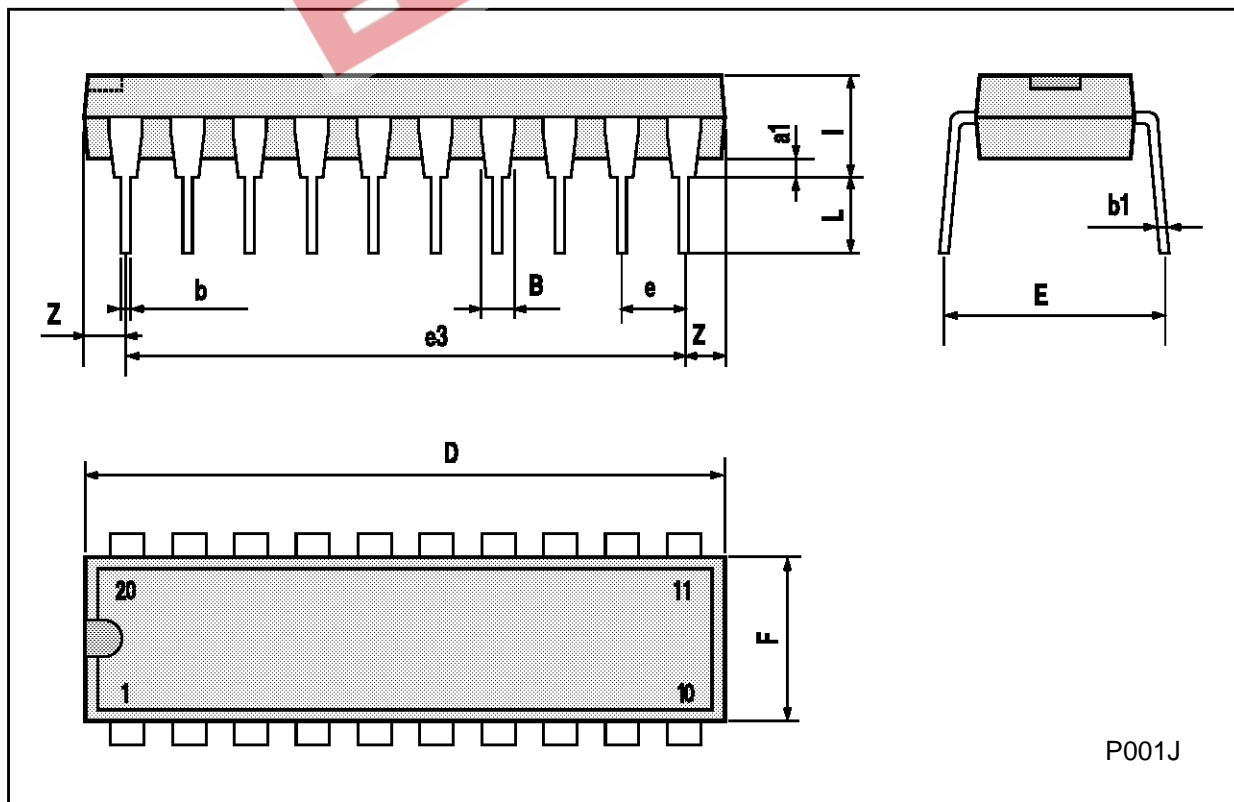

M54/M74HC620/623

Ceramic DIP20 MECHANICAL DATA

DIM.	mm			inch		
	MIN.	TYP.	MAX.	MIN.	TYP.	MAX.
A			25			0.984
B			7.8			0.307
D		3.3			0.130	
E	0.5		1.78	0.020		0.070
e3		22.86			0.900	
F	2.29		2.79	0.090		0.110
G	0.4		0.55	0.016		0.022
I	1.27		1.52	0.050		0.060
L	0.22		0.31	0.009		0.012
M	0.51		1.27	0.020		0.050
N1	4° (min.), 15° (max.)					
P	7.9		8.13	0.311		0.320
Q			5.71			0.225

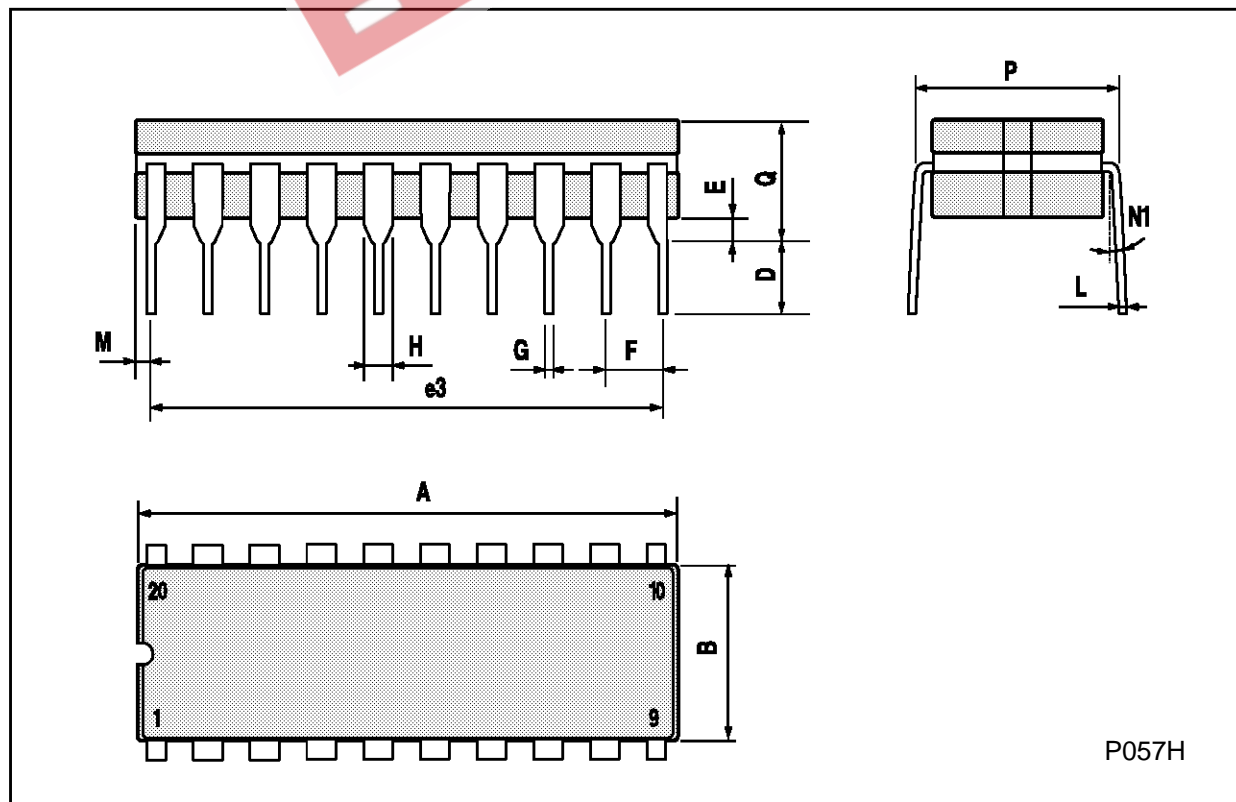

P057H

SO20 MECHANICAL DATA

DIM.	mm			inch		
	MIN.	TYP.	MAX.	MIN.	TYP.	MAX.
A			2.65			0.104
a1	0.10		0.20	0.004		0.007
a2			2.45			0.096
b	0.35		0.49	0.013		0.019
b1	0.23		0.32	0.009		0.012
C		0.50			0.020	
c1	45° (typ.)					
D	12.60		13.00	0.496		0.512
E	10.00		10.65	0.393		0.419
e		1.27			0.050	
e3		11.43			0.450	
F	7.40		7.60	0.291		0.299
L	0.50		1.27	0.19		0.050
M			0.75			0.029
S	8° (max.)					

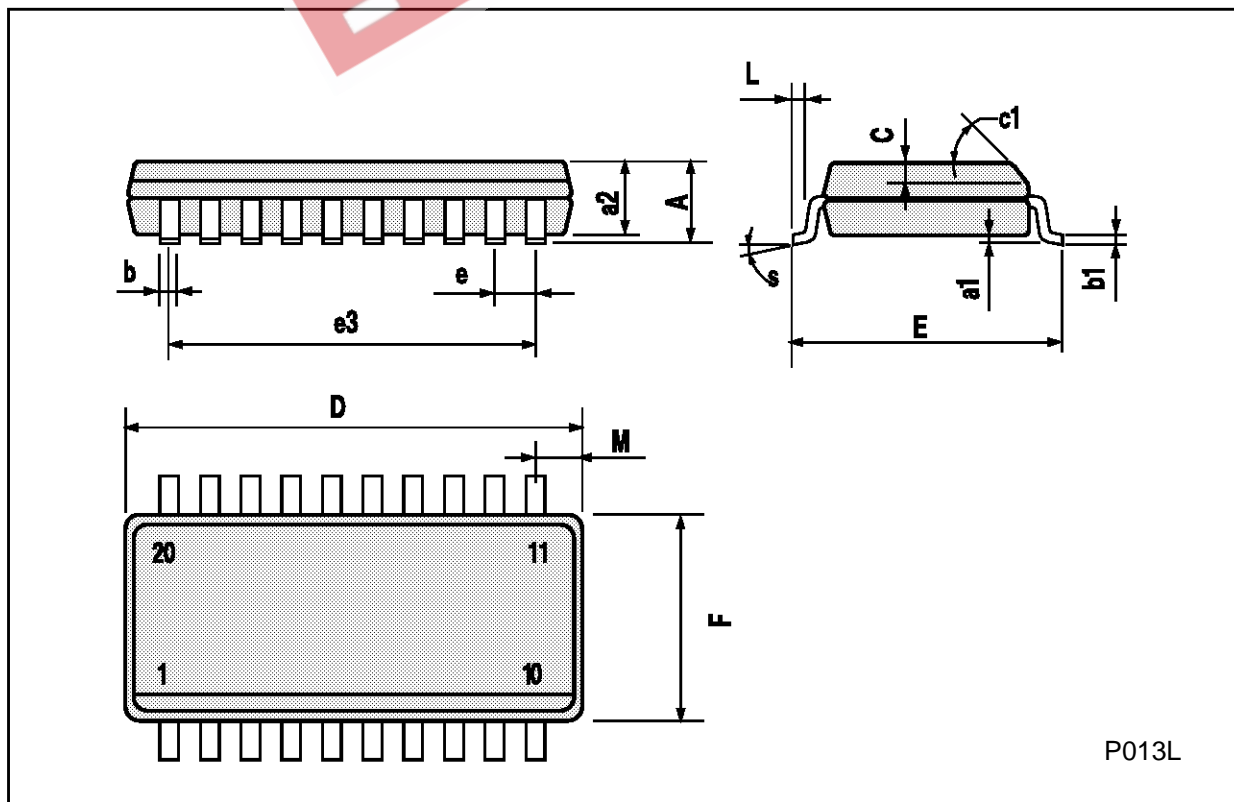

P013L

PLCC20 MECHANICAL DATA

DIM.	mm			inch		
	MIN.	TYP.	MAX.	MIN.	TYP.	MAX.
A	9.78		10.03	0.385		0.395
B	8.89		9.04	0.350		0.356
D	4.2		4.57	0.165		0.180
d1		2.54			0.100	
d2		0.56			0.022	
E	7.37		8.38	0.290		0.330
e		1.27			0.050	
e3		5.08			0.200	
F		0.38			0.015	
G			0.101			0.004
M		1.27			0.050	
M1		1.14			0.045	

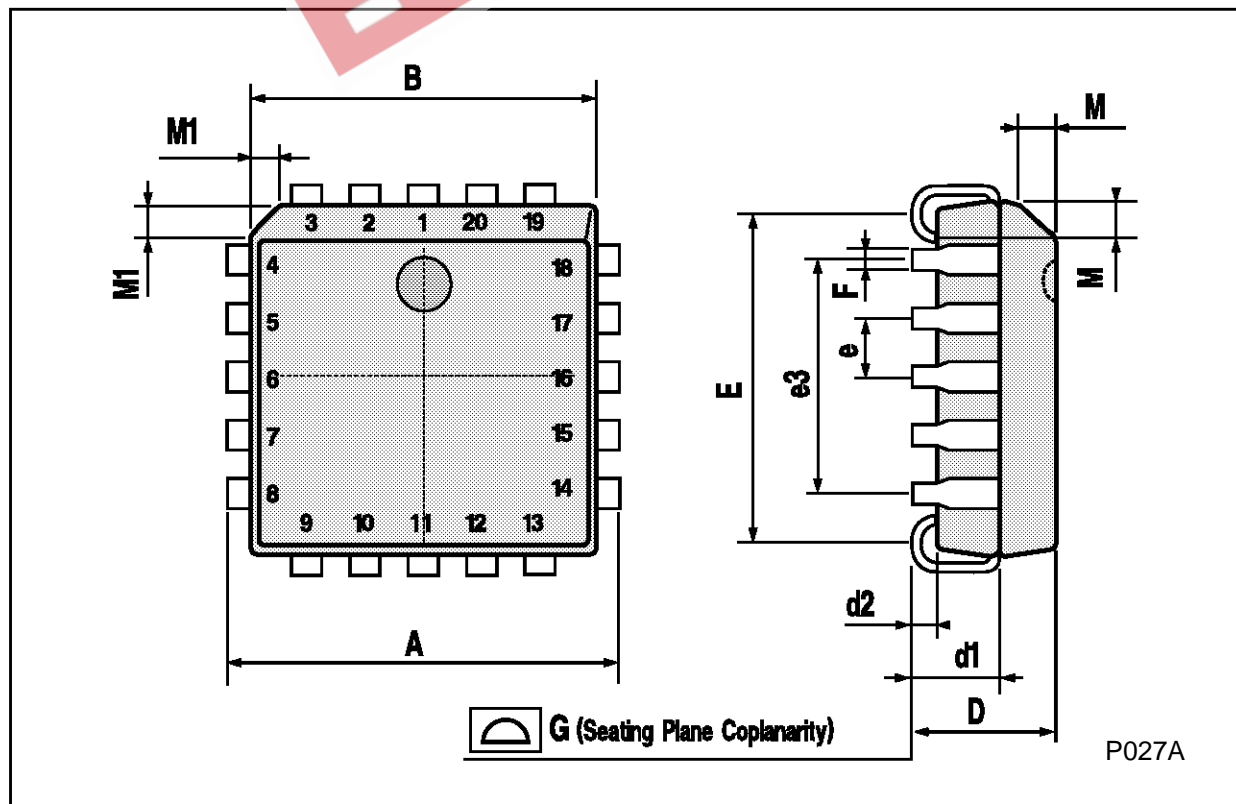

EEPW 电子產品世界
.com.cn

Information furnished is believed to be accurate and reliable. However, SGS-THOMSON Microelectronics assumes no responsibility for the consequences of use of such information nor for any infringement of patents or other rights of third parties which may result from its use. No license is granted by implication or otherwise under any patent or patent rights of SGS-THOMSON Microelectronics. Specifications mentioned in this publication are subject to change without notice. This publication supersedes and replaces all information previously supplied. SGS-THOMSON Microelectronics products are not authorized for use as critical components in life support devices or systems without express written approval of SGS-THOMSON Microelectronics.

© 1994 SGS-THOMSON Microelectronics - All Rights Reserved

SGS-THOMSON Microelectronics GROUP OF COMPANIES

Australia - Brazil - France - Germany - Hong Kong - Italy - Japan - Korea - Malaysia - Malta - Morocco - The Netherlands -
Singapore - Spain - Sweden - Switzerland - Taiwan - Thailand - United Kingdom - U.S.A