

DATA SHEET

74F543

Octal registered transceiver,
non-inverting (3-State)

74F544

Octal registered transceiver,
inverting (3-State)

Product specification

1994 Dec 5

IC15 Data Handbook

Philips Semiconductors



PHILIPS

Octal registered transceivers

74F543, 74F544

74F543 Octal registered transceiver, non-inverting (3-State)

74F544 Octal registered transceiver, inverting 93-State)

FEATURES

- Combines 74F245 and 74F373 type functions in one chip
- 8-bit octal transceiver with D-type latch
- 74F543 Non-inverting
74F544 Inverting
- Back-to-back registers for storage
- Separate controls for data flow in each direction
- A outputs sink 20mA and source 3mA
- B outputs sink 64mA and source 15mA
- 3-State outputs for bus-oriented applications
- 74F543 available in SSOP Type II package

DESCRIPTION

The 74F543 and 74F544 Octal Registered Transceivers contain two sets of D-type latches for temporary storage of data flowing in either direction. Separate Latch Enable (\overline{LEAB} , \overline{LEBA}) and Output Enable (\overline{OEAB} , \overline{OEBA}) inputs are provided for each register to permit independent control of inputting and outputting in either direction of data flow. While the 74F543 has non-inverting data path, the 74F544 inverts data in both directions. The A outputs are guaranteed to sink 24mA, while the B outputs are rated for 64mA.

FUNCTIONAL DESCRIPTION

The 74F543 and 74F544 contain two sets of eight D-type latches, with separate input and controls for each set. For data flow from A to B, for example, the A-to-B Enable (\overline{EAB}) input must be Low in order to enter data from A0 - A7 or take data from B0 - B7, as indicated in the Function Table. With \overline{EAB} Low, a Low signal on the A-to-B Latch Enable (\overline{LEAB}) input makes the A-to-B latches transparent; a subsequent Low-to-High transition for the \overline{LEAB} signal puts the A latches in the storage mode and their outputs no longer change with the A inputs. With \overline{EAB} and \overline{OEAB} both Low, the 3-State B output buffers are active and display the data present at the outputs of the A latches. Control of data flow from B to A is similar, but using the \overline{EBA} , \overline{LEBA} , and \overline{OEBA} inputs.

TYPE	TYPICAL PROPAGATION DELAY	TYPICAL SUPPLY CURRENT (TOTAL)
74F543	6.0ns	80mA
74F544	6.5ns	95mA

ORDERING INFORMATION

DESCRIPTION	COMMERCIAL RANGE $V_{CC} = 5V \pm 10\%$, $T_A = 0^\circ C$ to $+70^\circ C$	DRAWING NUMBER
24-pin plastic skinny DIP (300mil)	N74F543N, N74F544N	SOT222-1
24-pin plastic SOL	N74F543D, N74F544D	SOT137-1
24-pin plastic SSOP Type II	74F543DB	SOT340-1

INPUT AND OUTPUT LOADING AND FAN-OUT TABLE

PINS		DESCRIPTION	74F(U.L.) HIGH/LOW	LOAD VALUE HIGH/LOW
74F543 74F544	A0 - A7	Port A, 3-State inputs	3.5/1.0	70 μ A/0.6mA
	B0 - B7	Port B, 3-State inputs	3.5/1.0	70 μ A/0.6mA
	\overline{OEAB}	A-to-B Output Enable input (Active Low)	1.0/1.0	20 μ A/0.6mA
	\overline{OEBA}	B-to-A Output Enable input (Active Low)	1.0/1.0	20 μ A/0.6mA
	\overline{EAB}	A-to-B Enable input (Active Low)	1.0/2.0	20 μ A/1.2mA
	\overline{EBA}	B-to-A Enable input (Active Low)	1.0/2.0	20 μ A/1.2mA
	\overline{LEAB}	A-to-B Latch Enable input (Active Low)	1.0/1.0	20 μ A/0.6mA
	\overline{LEBA}	B-to-A Latch Enable input (Active Low)	1.0/1.0	20 μ A/0.6mA
74F543	A0 - A7	Port A, 3-State outputs	150/40	3.0mA/24mA
	B0 - B7	Port B, 3-State outputs	750/106.7	15mA/64mA
74F544	$\overline{A}0 - \overline{A}7$	Port \overline{A} , 3-State outputs	150/40	3.0mA/24mA
	$\overline{B}0 - \overline{B}7$	Port \overline{B} , 3-State outputs	750/106.7	15mA/64mA

NOTE: One (1.0) FAST Unit Load is defined as: 20 μ A in the High State and 0.6mA in the Low state.

Octal registered transceivers

74F543, 74F544

PIN CONFIGURATION – 74F543

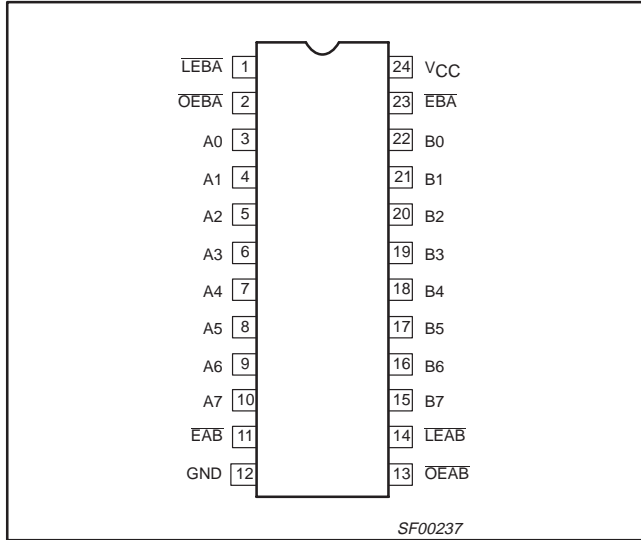

LOGIC SYMBOL – 74F543

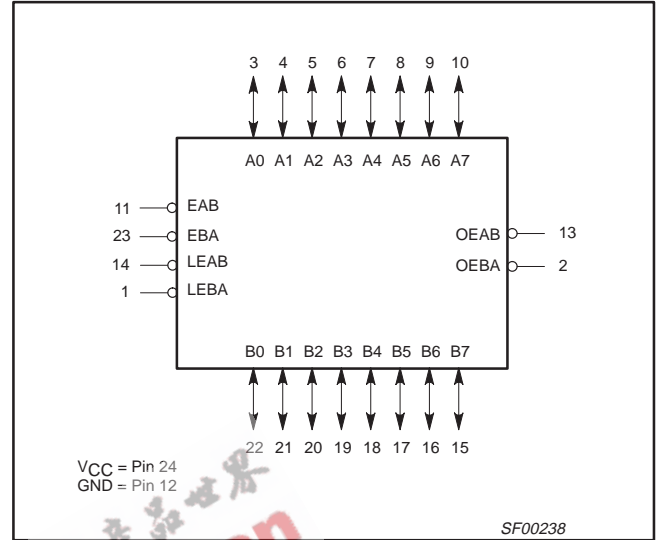

LOGIC SYMBOL (IEEE/IEC) – 74F543

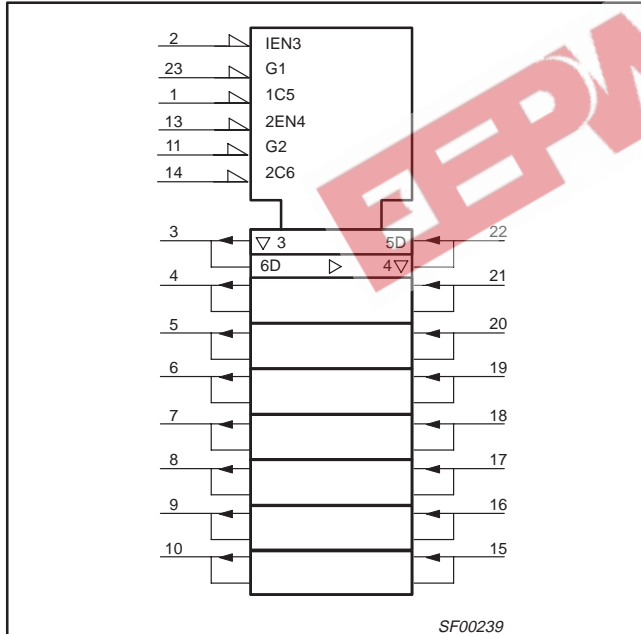

Octal registered transceivers

74F543, 74F544

PIN CONFIGURATION – 74F544

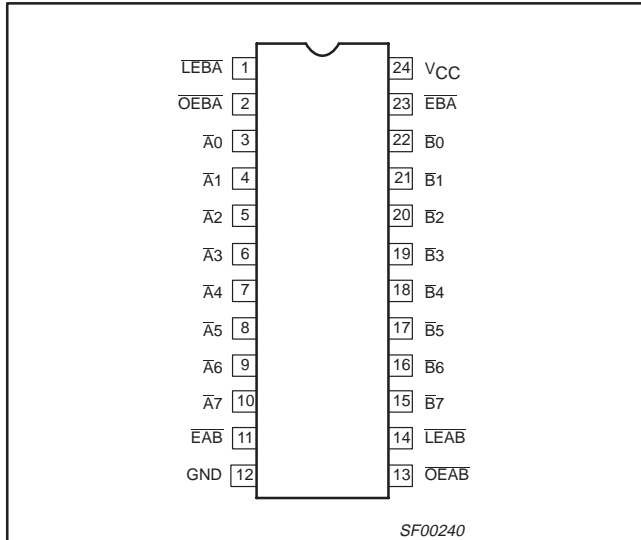

LOGIC SYMBOL – 74F544

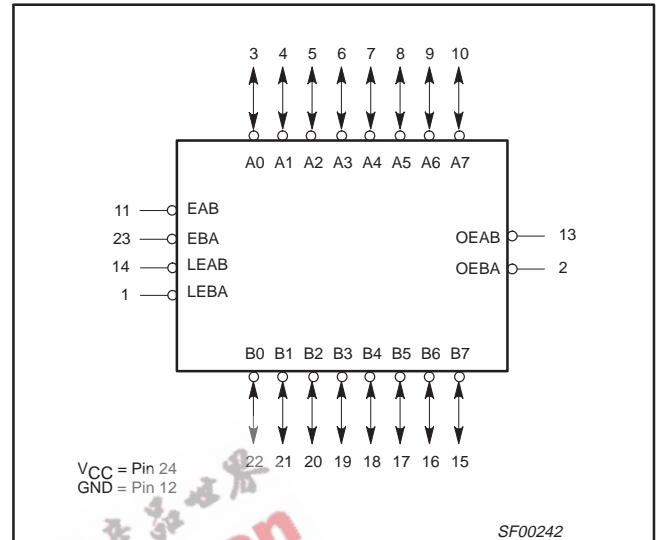

LOGIC SYMBOL (IEEE/IEC) – 74F544

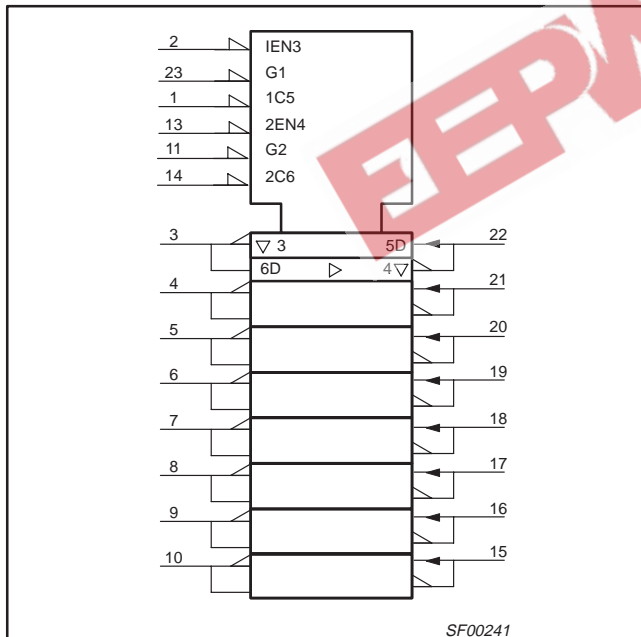

FUNCTION TABLE for 74F543 and 74F544

INPUTS				OUTPUTS		STATUS
OE \bar{X}	EX \bar{X}	LE \bar{X}	DATA	74F543	74F544	
H	X	X	X	Z	Z	Disabled
X	H	X	X	Z	Z	Disabled
L	\uparrow	L	h	Z	Z	Disable + Latch
L	\uparrow	L	l	Z	Z	Disable + Latch
L	L	\uparrow	h	H	L	Latch + Display
L	L	\uparrow	l	L	H	Latch + Display
L	L	L	H	H	L	Transparent
L	L	L	L	L	H	Transparent
L	L	H	X	NC	NC	Hold

- H = High voltage level
- L = Low voltage level
- h = High state must be present one setup time before the Low-to-High transition of $\bar{L}EX\bar{X}$ or $EX\bar{X}$ (XX=AB or BA)
- l = Low state must be present one setup time before the Low-to-High transition of $\bar{L}EX\bar{X}$ or $EX\bar{X}$ (XX=AB or BA)
- \uparrow = Low-to-High transition of $\bar{L}EX\bar{X}$ or $EX\bar{X}$ (XX = AB or BA)
- X = Don't care
- NC = No change
- Z = High impedance "off" state

Octal registered transceivers

74F543, 74F544

LOGIC DIAGRAM FOR 74F543

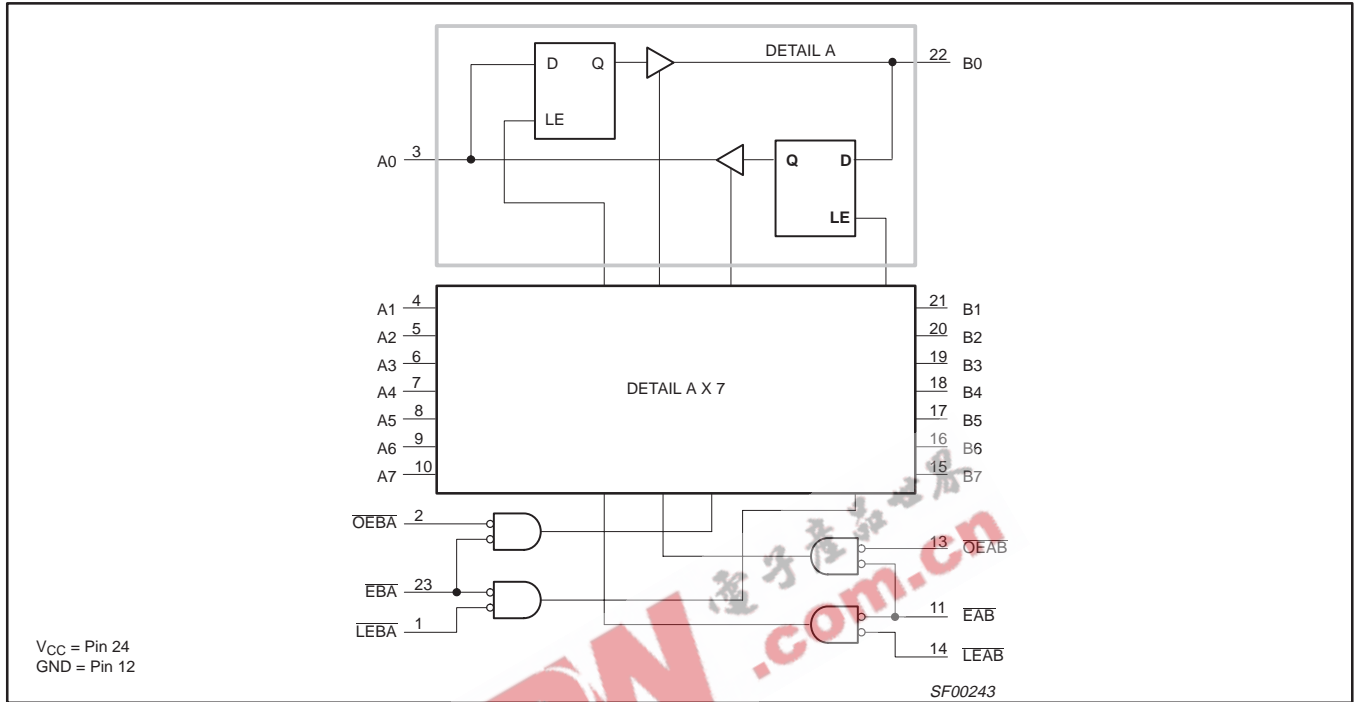

LOGIC DIAGRAM FOR 74F544

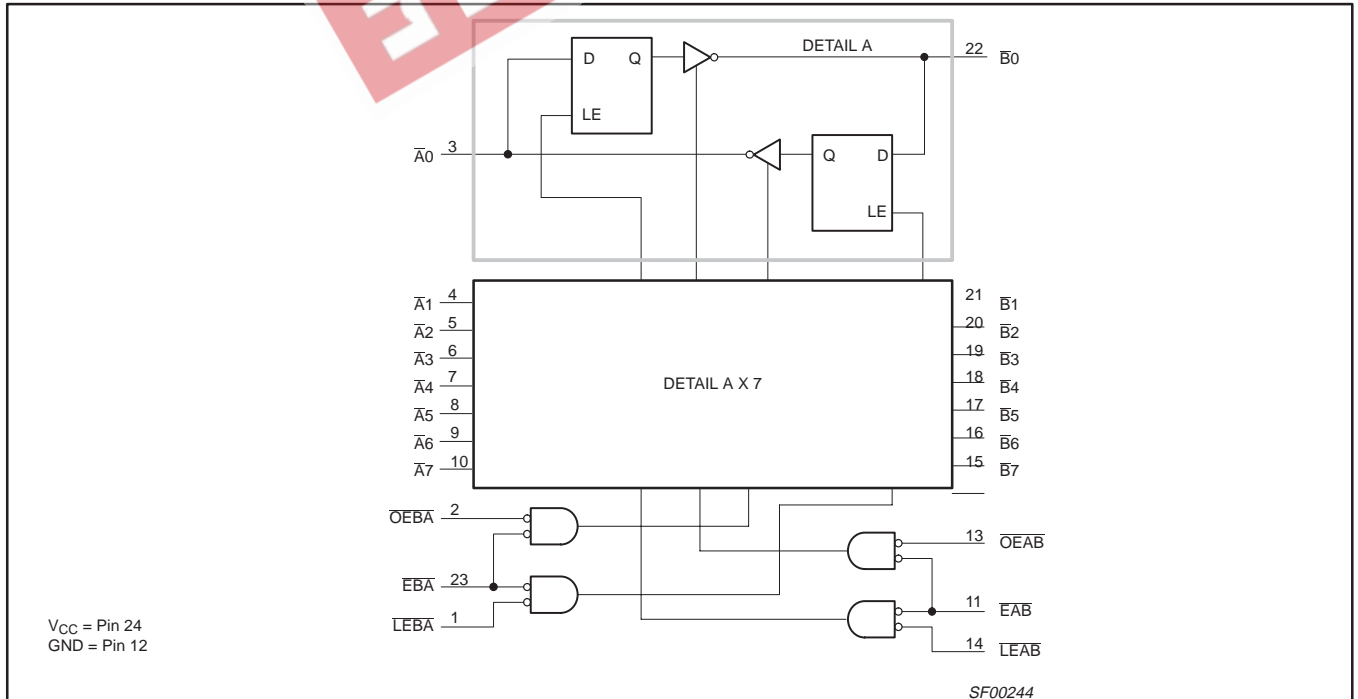

Octal registered transceivers

74F543, 74F544

ABSOLUTE MAXIMUM RATINGS

(Operation beyond the limits set forth in this table may impair the useful life of the device. Unless otherwise noted these limits are over the operating free-air temperature range.)

SYMBOL	PARAMETER		RATING	UNIT
V_{CC}	Supply voltage		-0.5 to +7.0	V
V_{IN}	Input voltage		-0.5 to +7.0	V
I_{IN}	Input current		-30 to +5	mA
V_{OUT}	Voltage applied to output in High output state		-0.5 to +5.5	V
I_{OUT}	Current applied to output in Low output state	A0 - A7, $\bar{A}0$ - $\bar{A}7$	48	mA
		B0 - B7, $\bar{B}0$ - $\bar{B}7$	128	mA
T_{amb}	Operating free-air temperature range		0 to +70	°C
T_{STG}	Storage temperature		-65 to +150	°C

RECOMMENDED OPERATING CONDITIONS

SYMBOL	PARAMETER	LIMITS			UNIT
		MIN	NOM	MAX	
V_{CC}	Supply voltage	4.5	5.0	5.5	V
V_{IH}	High-level input voltage	2.0			V
V_{IL}	Low-level input voltage			0.8	V
I_{IK}	Input clamp current			-18	mA
I_{OH}	High-level output current	A0 - A7, $\bar{A}0$ - $\bar{A}7$		-3	mA
		B0 - B7, $\bar{B}0$ - $\bar{B}7$		-15	mA
I_{OL}	Low-level output current	A0 - A7, $\bar{A}0$ - $\bar{A}7$		24	mA
		B0 - B7, $\bar{B}0$ - $\bar{B}7$		64	mA
T_{amb}	Operating free-air temperature range	-0		+70	°C

Octal registered transceivers

74F543, 74F544

DC ELECTRICAL CHARACTERISTICS

(Over recommended operating free-air temperature range unless otherwise noted.)

SYMBOL	PARAMETER		TEST CONDITIONS ¹			LIMITS			UNIT	
						MIN	TYP ²	MAX		
V _{OH}	High-level output voltage	A0 - A7, A0 - A7	V _{CC} = MIN V _{IL} = MAX	I _{OH} = -3mA	± 10%V _{CC}	2.4			V	
					± 5%V _{CC}	2.7	3.4		V	
		B0 - B7, B0 - B7	V _{CC} = MIN V _{IH} = MIN	I _{OH} = -15mA	± 10%V _{CC}	2.0			V	
					± 5%V _{CC}	2.0			V	
V _{OL}	Low-level output voltage	A0 - A7, A0 - A7	V _{CC} = MIN V _{IL} = MAX	I _{OL} = 24mA	± 10%V _{CC}		0.35	0.50	V	
					± 5%V _{CC}		0.35	0.50	V	
		B0 - B7, B0 - B7	V _{CC} = MIN V _{IH} = MIN	I _{OL} = 64mA	± 10%V _{CC}			0.55	V	
					± 5%V _{CC}		0.42	0.55	V	
V _{IK}	Input clamp voltage		V _{CC} = MIN, I _I = I _{IK}				-0.73	-1.2	V	
I _I	Input current at maximum input voltage	OEAB, OEBA, EAB	V _{CC} = MAX, V _I = 7.0 V					100	μA	
		Others	V _{CC} = 5.5, V _I = 5.5V					1	mA	
I _{IH}	High-level input current		V _{CC} = MAX, V _I = 2.7V					20	μA	
I _{IL}	Low-level input current	Others	V _{CC} = MAX, V _I = 0.5V					-0.6	mA	
		EAB, EBA	V _{CC} = MAX, V _I = 0.5V					-1.2	mA	
I _{OZH} + I _{IH}	Off-state output current, high-level voltage applied		V _{CC} = MAX, V _O = 2.7V					70	μA	
I _{OZH} + I _{IL}	Off-state output current, Low-level voltage applied		V _{CC} = MAX, V _O = 0.5V					-600	μA	
I _{OS}	Short-circuit output current ³	A0 - A7, A0 - A7	V _{CC} = MAX			-60		-150	mA	
		B0 - B7, B0 - B7	V _{CC} = MAX			-100		-225	mA	
I _{CC}	Supply current (total)	74F543	I _{CCH}	V _{CC} = MAX				70	105	mA
			I _{CCL}	V _{CC} = MAX				95	135	mA
			I _{CCZ}	V _{CC} = MAX				95	135	mA
		74F544	I _{CCH}	V _{CC} = MAX				80	110	mA
			I _{CCL}	V _{CC} = MAX				105	140	mA
			I _{CCZ}	V _{CC} = MAX				100	135	mA

NOTES:

- For conditions shown as MIN or MAX, use the appropriate value specified under the recommended operating conditions for the applicable type.
- All typical values are at V_{CC} = 5V, T_{amb} = 25°C.
- Not more than one output should be shorted at a time. For testing I_{OS}, the use of high-speed test apparatus and/or sample-and-hold techniques are preferable in order to minimize internal heating and more accurately reflect operational values. Otherwise, prolonged shorting of a High output may raise the chip temperature well above normal and thereby cause invalid readings in other parameter tests. In any sequence of parameter tests, I_{OS} tests should be performed last.

Octal registered transceivers

74F543, 74F544

AC ELECTRICAL CHARACTERISTICS FOR 74F543

SYMBOL	PARAMETER	TEST CONDITIONS	74F543 LIMITS						UNIT
			T _{amb} = +25°C V _{CC} = 5.0V C _L = 50pF R _L = 500Ω			T _{amb} = 0°C to +70°C V _{CC} = 5.0V ± 10% C _L = 50pF R _L = 500Ω			
			MIN	TYP	MAX	MIN	MAX		
t _{PLH} t _{PHL}	Propagation delay A _n to B _n	Waveform 2	3.5 3.0	5.5 5.0	8.5 8.0	3.0 2.5	9.0 8.5	ns	
t _{PLH} t _{PHL}	Propagation delay B _n to A _n	Waveform 2	2.5 2.5	4.0 4.5	7.0 7.5	2.5 2.5	7.5 8.0	ns	
t _{PLH} t _{PHL}	Propagation delay LEB _A to A _n	Waveform NO TAG, 2	5.0 4.0	7.0 6.0	10.0 9.0	4.5 4.0	11.0 9.5	ns	
t _{PLH} t _{PHL}	Propagation delay LEAB to B _n	Waveform NO TAG, 2	6.0 4.5	8.5 6.5	11.5 9.5	5.5 4.0	12.5 10.0	ns	
t _{PZH} t _{PZL}	Output Enable time OEBA to A _n or OEAB to B _n	Waveform 4 Waveform 5	2.0 3.5	4.0 5.0	7.5 8.5	1.5 3.0	8.0 9.0	ns	
t _{PHZ} t _{PLZ}	Output Disable time OEBA to A _n or OEAB to B _n	Waveform 4 Waveform 5	1.0 1.5	3.0 4.0	6.5 7.5	1.0 1.0	7.5 8.5	ns	
t _{PZH} t _{PZL}	Output Enable time EB _A to A _n or EAB to B _n	Waveform 4 Waveform 5	4.5 5.0	7.0 7.0	10.5 10.5	4.0 4.5	11.5 11.0	ns	
t _{PHZ} t _{PLZ}	Output Disable time EB _A to A _n or EAB to B _n	Waveform 4 Waveform 5	2.5 4.5	5.0 7.0	8.5 11.0	2.0 3.0	9.5 12.0	ns	

AC SETUP REQUIREMENTS FOR 74F543

SYMBOL	PARAMETER	TEST CONDITIONS	74F543 LIMITS				UNIT
			T _{amb} = +25°C V _{CC} = 5.0V C _L = 50pF R _L = 500Ω		T _{amb} = 0°C to +70°C V _{CC} = 5.0V ± 10% C _L = 50pF R _L = 500Ω		
			MIN	TYP	MIN	MAX	
t _s (H) t _s (L)	Setup time, High or Low A _n to LEAB or B _n to LEBA	Waveform 3	0.0 2.5		0.0 3.0		ns
t _h (H) t _h (L)	Hold time, High or Low A _n to LEAB or B _n to LEBA	Waveform 3	0.0 1.5		0.0 2.0		ns
t _s (H) t _s (L)	Setup time, High or Low A _n to EAB or B _n to EBA	Waveform 3	1.0 2.5		1.5 3.0		ns
t _h (H) t _h (L)	Hold time, High or Low A _n to EAB or B _n to EBA	Waveform 3	0.0 1.5		0.0 2.0		ns
t _w (L)	Latch enable pulse width, Low	Waveform 3	4.0		4.5		ns

Octal registered transceivers

74F543, 74F544

AC ELECTRICAL CHARACTERISTICS FOR 74F544

SYMBOL	PARAMETER	TEST CONDITIONS	74F544 LIMITS					UNIT
			T _{amb} = +25°C V _{CC} = 5.0V C _L = 50pF R _L = 500Ω			T _{amb} = 0°C to +70°C V _{CC} = 5.0V ± 10% C _L = 50pF R _L = 500Ω		
			MIN	TYP	MAX	MIN	MAX	
t _{PLH} t _{PHL}	Propagation delay \overline{A}_n to \overline{B}_n or \overline{B}_n to \overline{A}_n	Waveform NO TAG	3.0 3.0	6.5 5.0	9.5 8.0	3.0 3.0	10.5 8.5	ns
t _{PLH} t _{PHL}	Propagation delay \overline{LEBA} to \overline{A}_n	Waveform NO TAG, 2	4.0 4.0	7.0 7.0	9.5 9.5	4.0 4.0	10.5 10.5	ns
t _{PLH} t _{PHL}	Propagation delay \overline{LEAB} to \overline{B}_n	Waveform NO TAG, 2	5.0 4.0	8.0 7.5	11.5 9.5	4.0 4.0	12.5 10.5	ns
t _{PZH} t _{PZL}	Output Enable time \overline{OEBA} to \overline{A}_n or \overline{OEAB} to \overline{B}_n	Waveform 4 Waveform 5	2.0 3.5	4.0 5.5	7.0 8.5	1.5 3.0	7.5 9.0	ns
t _{PHZ} t _{PLZ}	Output Disable time \overline{OEBA} to \overline{A}_n or \overline{OEAB} to \overline{B}_n	Waveform 4 Waveform 5	1.0 1.5	4.0 4.0	6.5 6.5	1.0 1.5	7.0 7.5	ns
t _{PZH} t _{PZL}	Output Enable time \overline{EBA} to \overline{A}_n or \overline{EAB} to \overline{B}_n	Waveform 4 Waveform 5	4.0 4.5	7.0 8.0	9.5 11.0	3.5 4.5	10.0 12.0	ns
t _{PHZ} t _{PLZ}	Output Disable time \overline{EBA} to \overline{A}_n or \overline{EAB} to \overline{B}_n	Waveform 4 Waveform 5	2.5 4.5	5.0 8.5	8.0 11.5	2.5 4.0	9.0 11.5	ns

AC SETUP REQUIREMENTS FOR 74F544

SYMBOL	PARAMETER	TEST CONDITIONS	74F544 LIMITS				UNIT
			T _{amb} = +25°C V _{CC} = 5.0V C _L = 50pF R _L = 500Ω		T _{amb} = 0°C to +70°C V _{CC} = 5.0V ± 10% C _L = 50pF R _L = 500Ω		
			MIN	TYP	MIN	MAX	
t _s (H) t _s (L)	Setup time, High or Low \overline{A}_n to \overline{LEAB} or \overline{B}_n to \overline{LEBA}	Waveform 3	1.5 1.5		2.0 2.5		ns
t _h (H) t _h (L)	Hold time, High or Low \overline{A}_n to \overline{LEAB} or \overline{B}_n to \overline{LEBA}	Waveform 3	1.5 2.0		2.5 2.5		ns
t _s (H) t _s (L)	Setup time, High or Low A _n to \overline{EAB} or B _n to \overline{EBA}	Waveform 3	1.5 1.5		2.5 2.5		ns
t _h (H) t _h (L)	Hold time, High or Low \overline{A}_n to \overline{EAB} or \overline{B}_n to \overline{EBA}	Waveform 3	1.5 2.0		2.0 2.0		ns
t _w (L)	Latch enable pulse width, Low	Waveform 3	4.0		4.5		ns

Octal registered transceivers

74F543, 74F544

AC WAVEFORMS

$V_M = 1.5V$

The shaded areas indicate when the input is permitted to change for predictable output performance.

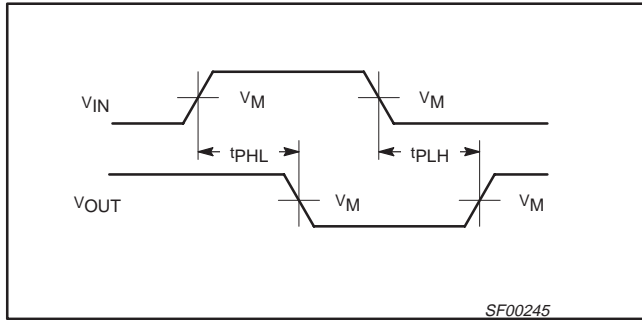

Waveform 1. Propagation Delay for Inverting Outputs

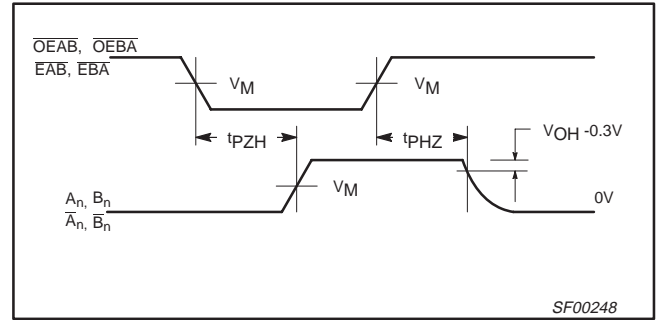

Waveform 4. 3-State Output Enable Time to High Level and Output Disable Time from High Level

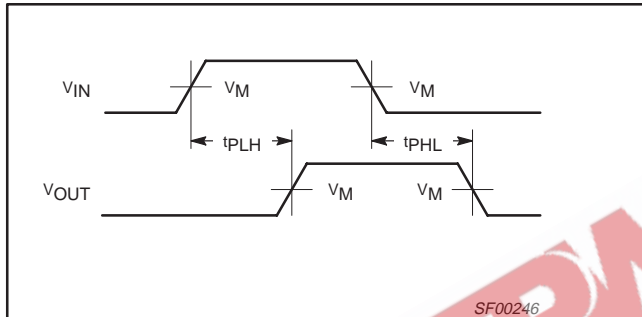

Waveform 2. Propagation Delay for Non-Inverting Outputs

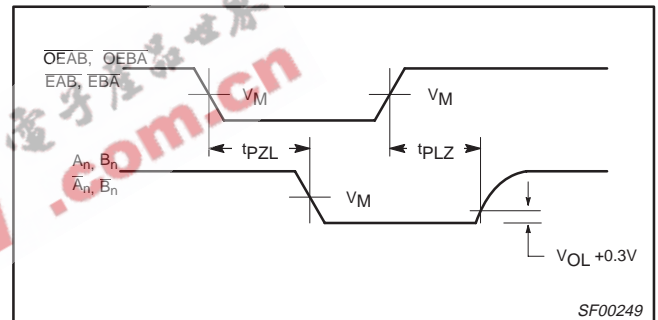

Waveform 5. 3-State Output Enable Time to Low Level and Output Disable Time from Low Level

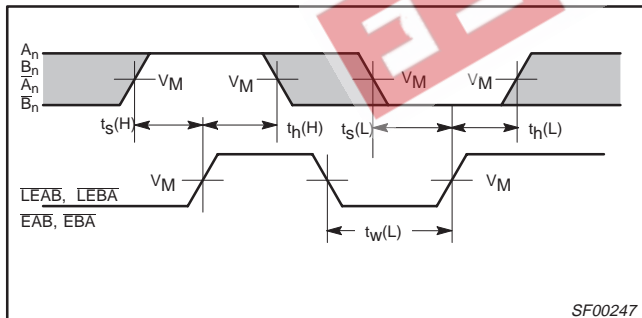

Waveform 3. Data Setup Time and Hold Times, and Latch Enable Pulse Width

Octal registered transceivers

74F543, 74F544

TEST CIRCUIT AND WAVEFORMS

Test Circuit for Open Collector Outputs

SWITCH POSITION

TEST	SWITCH
t_{PLZ}	closed
t_{PZL}	closed
All other	open

DEFINITIONS:
 R_L = Load resistor; see AC electrical characteristics for value.
 C_L = Load capacitance includes jig and probe capacitance; see AC electrical characteristics for value.
 R_T = Termination resistance should be equal to Z_{OUT} of pulse generators.

Input Pulse Definition

INPUT PULSE REQUIREMENTS						
family	amplitude	V_M	rep. rate	t_w	t_{TLH}	t_{THL}
74F	3.0V	1.5V	1MHz	500ns	2.5ns	2.5ns

SF00128

Bus transceivers

74F543, 74F544

DIP24: plastic dual in-line package; 24 leads (300 mil)

SOT222-1

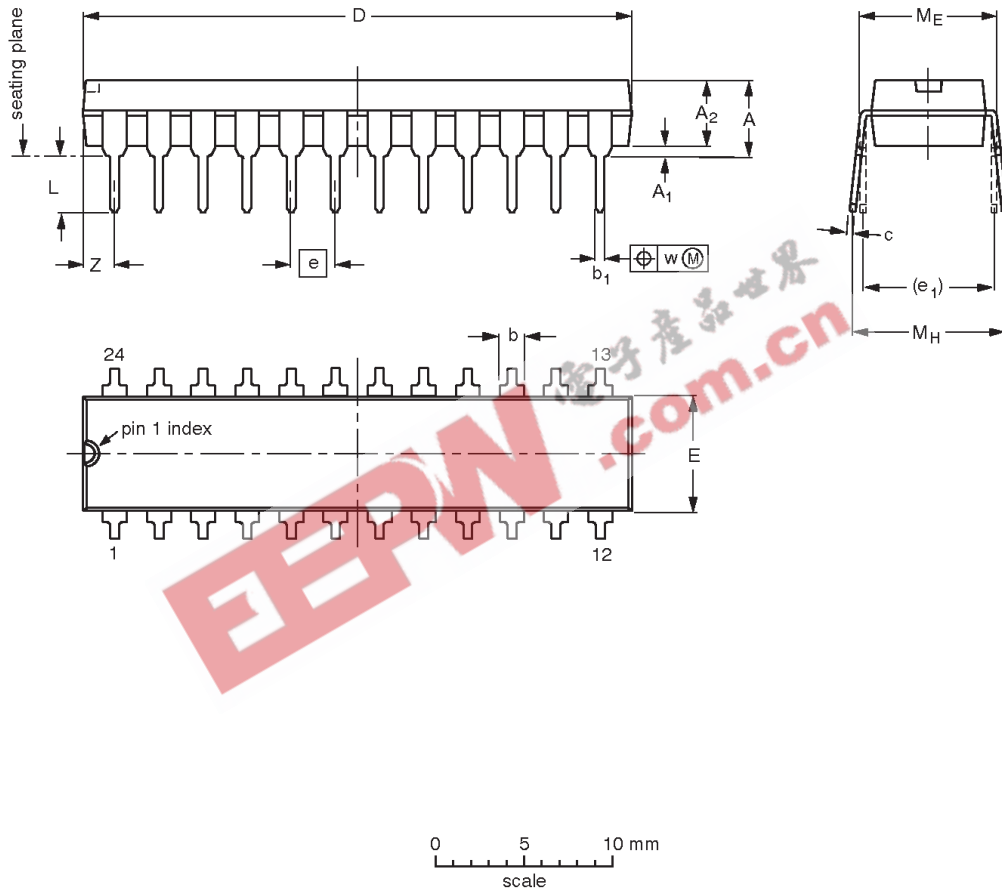

DIMENSIONS (millimetre dimensions are derived from the original inch dimensions)

UNIT	A max.	A1 min.	A2 max.	b	b1	c	D ⁽¹⁾	E ⁽¹⁾	e	e1	L	ME	MH	w	Z ⁽¹⁾ max.
mm	4.70	0.38	3.94	1.63 1.14	0.56 0.43	0.36 0.25	31.9 31.5	6.73 6.48	2.54	7.62	3.51 3.05	8.13 7.62	10.03 7.62	0.25	2.05
inches	0.185	0.015	0.155	0.064 0.045	0.022 0.017	0.014 0.010	1.256 1.240	0.265 0.255	0.100	0.300	0.138 0.120	0.32 0.30	0.395 0.300	0.01	0.081

Note

1. Plastic or metal protrusions of 0.01 inches maximum per side are not included.

OUTLINE VERSION	REFERENCES				EUROPEAN PROJECTION	ISSUE DATE
	IEC	JEDEC	EIAJ			
SOT222-1		MS-001AF				95-03-11

Bus transceivers

74F543, 74F544

SO24: plastic small outline package; 24 leads; body width 7.5 mm

SOT137-1

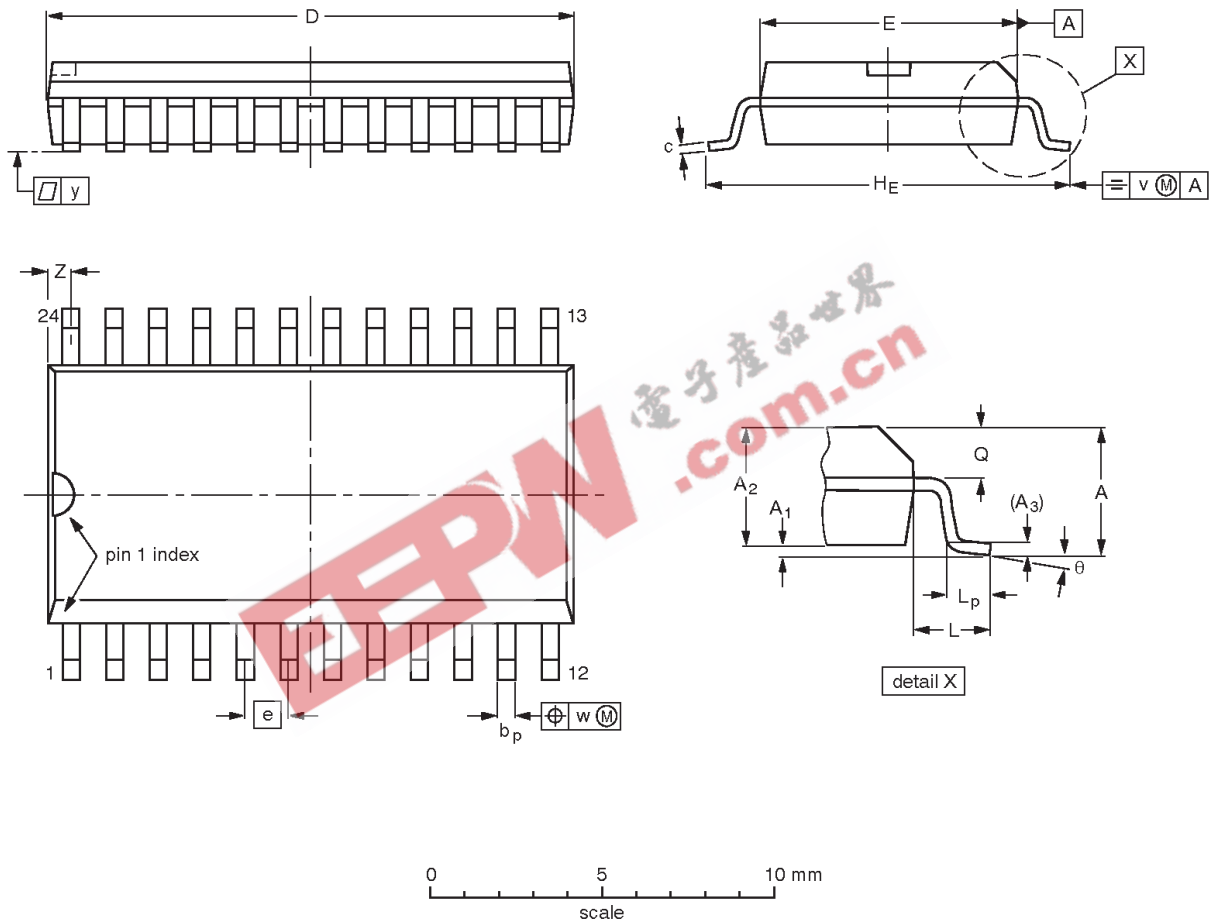

DIMENSIONS (inch dimensions are derived from the original mm dimensions)

UNIT	A max.	A ₁	A ₂	A ₃	b _p	c	D ⁽¹⁾	E ⁽¹⁾	e	H _E	L	L _p	Q	v	w	y	Z ⁽¹⁾	θ
mm	2.65	0.30 0.10	2.45 2.25	0.25	0.49 0.36	0.32 0.23	15.6 15.2	7.6 7.4	1.27	10.65 10.00	1.4	1.1 0.4	1.1 1.0	0.25	0.25	0.1	0.9 0.4	8° 0°
inches	0.10	0.012 0.004	0.096 0.089	0.01	0.019 0.014	0.013 0.009	0.61 0.60	0.30 0.29	0.050	0.419 0.394	0.055	0.043 0.016	0.043 0.039	0.01	0.01	0.004	0.035 0.016	

Note

1. Plastic or metal protrusions of 0.15 mm maximum per side are not included.

OUTLINE VERSION	REFERENCES				EUROPEAN PROJECTION	ISSUE DATE
	IEC	JEDEC	EIAJ			
SOT137-1	075E05	MS-013AD				95-01-24 97-05-22

Bus transceivers

74F543, 74F544

SSOP24: plastic shrink small outline package; 24 leads; body width 5.3 mm

SOT340-1

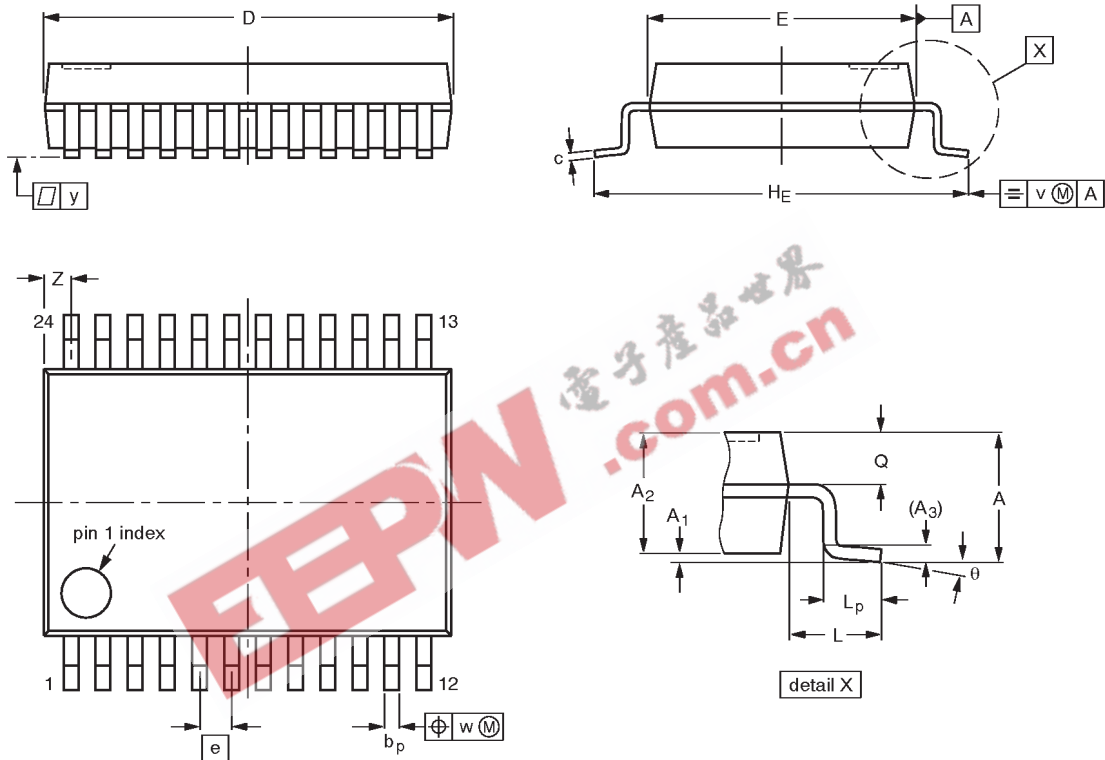

DIMENSIONS (mm are the original dimensions)

UNIT	A max.	A ₁	A ₂	A ₃	b _p	c	D ⁽¹⁾	E ⁽¹⁾	e	H _E	L	L _p	Q	v	w	y	Z ⁽¹⁾	θ
mm	2.0	0.21 0.05	1.80 1.65	0.25	0.38 0.25	0.20 0.09	8.4 8.0	5.4 5.2	0.65	7.9 7.6	1.25	1.03 0.63	0.9 0.7	0.2	0.13	0.1	0.8 0.4	8° 0°

Note

1. Plastic or metal protrusions of 0.20 mm maximum per side are not included.

OUTLINE VERSION	REFERENCES				EUROPEAN PROJECTION	ISSUE DATE
	IEC	JEDEC	EIAJ			
SOT340-1		MO-150AG				93-09-08 95-02-04

Bus transceivers

74F543, 74F544

NOTES

EEPW 电子产品世界
.com.cn

Octal registered transceivers

74F543, 74F544

DEFINITIONS

Data Sheet Identification	Product Status	Definition
<i>Objective Specification</i>	Formative or in Design	This data sheet contains the design target or goal specifications for product development. Specifications may change in any manner without notice.
<i>Preliminary Specification</i>	Preproduction Product	This data sheet contains preliminary data, and supplementary data will be published at a later date. Philips Semiconductors reserves the right to make changes at any time without notice in order to improve design and supply the best possible product.
<i>Product Specification</i>	Full Production	This data sheet contains Final Specifications. Philips Semiconductors reserves the right to make changes at any time without notice, in order to improve design and supply the best possible product.

Philips Semiconductors and Philips Electronics North America Corporation reserve the right to make changes, without notice, in the products, including circuits, standard cells, and/or software, described or contained herein in order to improve design and/or performance. Philips Semiconductors assumes no responsibility or liability for the use of any of these products, conveys no license or title under any patent, copyright, or mask work right to these products, and makes no representations or warranties that these products are free from patent, copyright, or mask work right infringement, unless otherwise specified. Applications that are described herein for any of these products are for illustrative purposes only. Philips Semiconductors makes no representation or warranty that such applications will be suitable for the specified use without further testing or modification.

LIFE SUPPORT APPLICATIONS

Philips Semiconductors and Philips Electronics North America Corporation Products are not designed for use in life support appliances, devices, or systems where malfunction of a Philips Semiconductors and Philips Electronics North America Corporation Product can reasonably be expected to result in a personal injury. Philips Semiconductors and Philips Electronics North America Corporation customers using or selling Philips Semiconductors and Philips Electronics North America Corporation Products for use in such applications do so at their own risk and agree to fully indemnify Philips Semiconductors and Philips Electronics North America Corporation for any damages resulting from such improper use or sale.

Philips Semiconductors
811 East Arques Avenue
P.O. Box 3409
Sunnyvale, California 94088-3409
Telephone 800-234-7381

Philips Semiconductors and Philips Electronics North America Corporation register eligible circuits under the Semiconductor Chip Protection Act.
 © Copyright Philips Electronics North America Corporation 1994
 All rights reserved. Printed in U.S.A.

(print code)

Date of release: July 1994

Document order number:

9397-750-05135