



74VCX16240

LOW VOLTAGE CMOS 16-BIT BUS BUFFER (3-STATE INV.) WITH 3.6V TOLERANT INPUTS AND OUTPUTS

- 3.6V TOLERANT INPUTS AND OUTPUTS
- HIGH SPEED :
 - $t_{PD} = 2.5 \text{ ns (MAX.)}$ at $V_{CC} = 3.0 \text{ to } 3.6\text{V}$
 - $t_{PD} = 3.0 \text{ ns (MAX.)}$ at $V_{CC} = 2.3 \text{ to } 2.7\text{V}$
 - $t_{PD} = 5.0 \text{ ns (MAX.)}$ at $V_{CC} = 1.8\text{V}$
- POWER DOWN PROTECTION ON INPUTS AND OUTPUTS
- SYMMETRICAL OUTPUT IMPEDANCE:
 - $|I_{OH}| = I_{OL} = 24\text{mA (MIN)}$ at $V_{CC} = 3.0\text{V}$
 - $|I_{OH}| = I_{OL} = 18\text{mA (MIN)}$ at $V_{CC} = 2.3\text{V}$
 - $|I_{OH}| = I_{OL} = 6\text{mA (MIN)}$ at $V_{CC} = 1.8\text{V}$
- OPERATING VOLTAGE RANGE:
 $V_{CC(OPR)} = 1.8\text{V to } 3.6\text{V}$
- PIN AND FUNCTION COMPATIBLE WITH 74 SERIES 16240
- LATCH-UP PERFORMANCE EXCEEDS 300mA (JESD 17)
- ESD PERFORMANCE:
HBM > 2000V (MIL STD 883 method 3015);
MM > 200V

DESCRIPTION

The 74VCX16240 is a low voltage CMOS 16 BIT BUS BUFFER (INVERTED) fabricated with sub-micron silicon gate and five-layer metal wiring C²MOS technology. It is ideal for low power and very high speed 1.8 to 3.6V applications; it can be interfaced to 3.6V signal environment for both inputs and outputs.

Any \overline{nG} output control governs four BUS BUFFERS. Output Enable input (\overline{nG}) tied together gives full 16-bit operation.

When \overline{nG} is LOW, the outputs are on. When \overline{nG} is HIGH, the output are in high impedance state.

This device is designed to be used with 3 state memory address drivers, etc.

All inputs and outputs are equipped with protection circuits against static discharge, giving them 2KV ESD immunity and transient excess voltage.

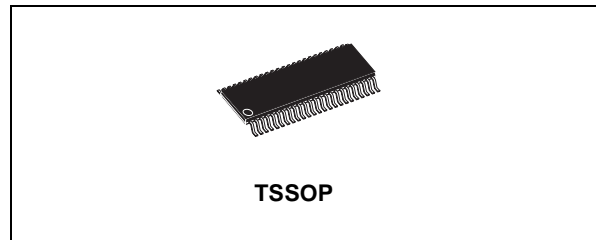

ORDER CODES

PACKAGE	TUBE	T & R
TSSOP		74VCX16240TTR

PIN CONNECTION

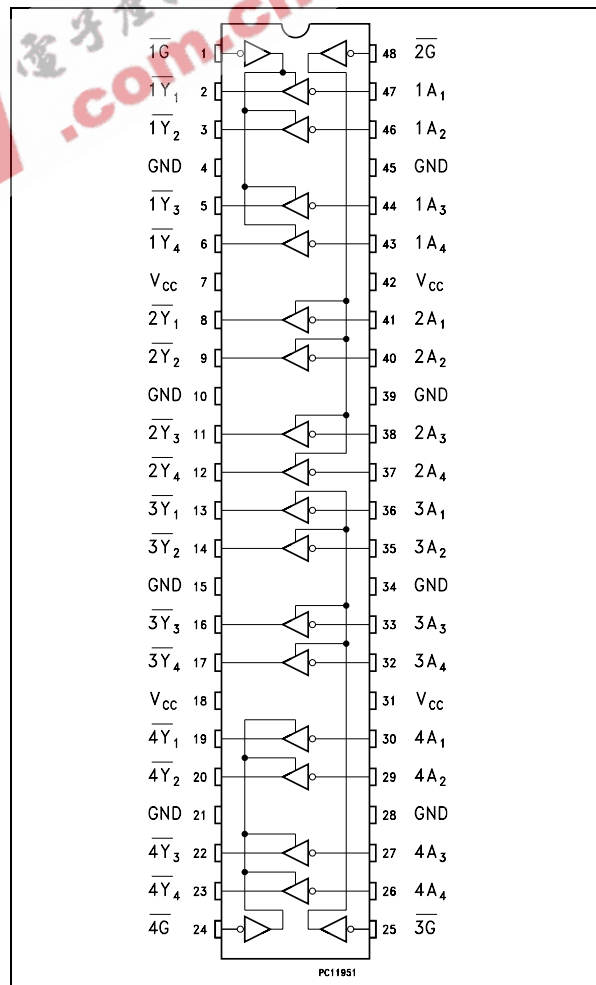

INPUT AND OUTPUT EQUIVALENT CIRCUIT

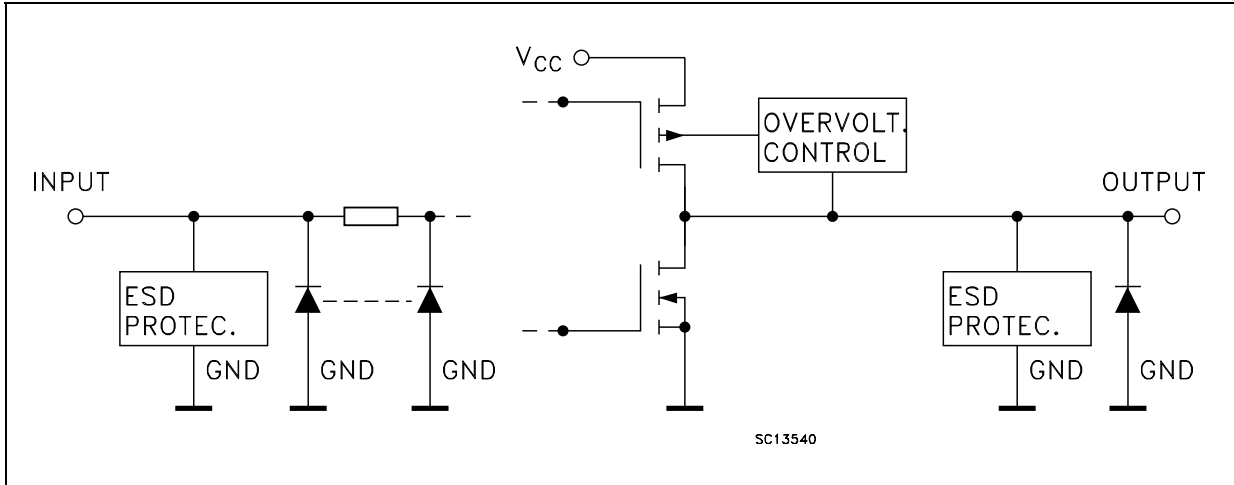

PIN DESCRIPTION

PIN No	SYMBOL	NAME AND FUNCTION
1	1G	Output Enable Input
2, 3, 5, 6	1Y1 to 1Y4	Data Outputs
8, 9, 11, 12	2Y1 to 2Y4	Data Outputs
13, 14, 16, 17	3Y1 to 3Y4	Data Outputs
19, 20, 22, 23	4Y1 to 4Y4	Data Outputs
24	4G	Output Enable Input
25	3G	Output Enable Input
30, 29, 27, 26	4A1 to 4A4	Data Outputs
36, 35, 33, 32	3A1 to 3A4	Data Outputs
41, 40, 38, 37	2A1 to 2A4	Data Outputs
47, 46, 44, 43	1A1 to 1A4	Data Outputs
48	2G	Output Enable Input
4, 10, 15, 21, 28, 34, 39, 45	GND	Ground (0V)
7, 18, 31, 42	VCC	Positive Supply Voltage

TRUTH TABLE

INPUTS		OUTPUT
\bar{G}	A _n	\bar{Y}_n
L	L	H
L	H	L
H	X	Z

X : Don't Care
Z : High Impedance

IEC LOGIC SYMBOLS

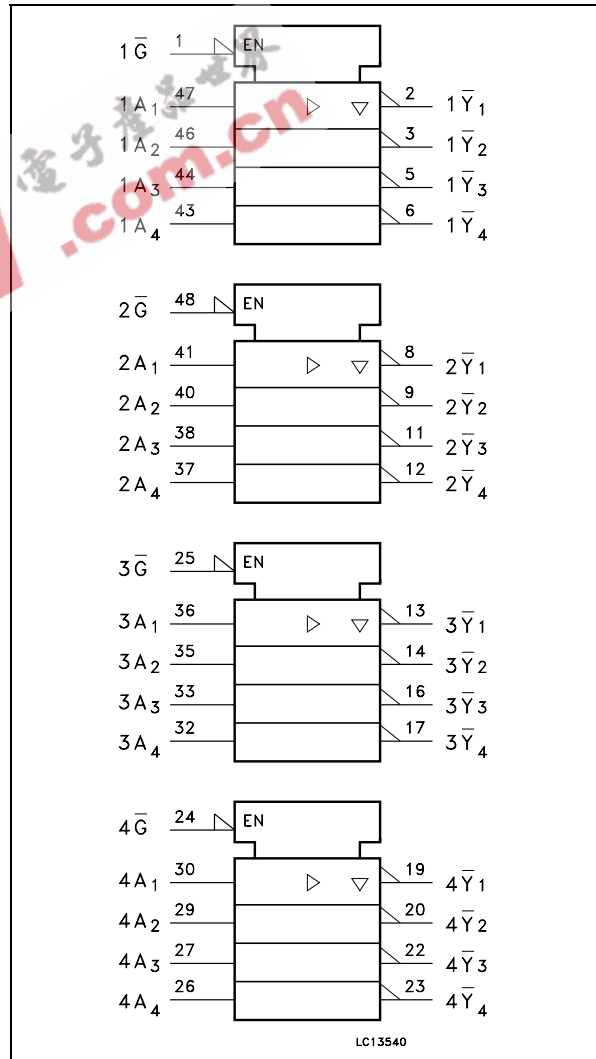

ABSOLUTE MAXIMUM RATINGS

Symbol	Parameter	Value	Unit
V_{CC}	Supply Voltage	-0.5 to +4.6	V
V_I	DC Input Voltage	-0.5 to +4.6	V
V_O	DC Output Voltage (OFF State)	-0.5 to +4.6	V
V_O	DC Output Voltage (High or Low State) (note 1)	-0.5 to $V_{CC} + 0.5$	V
I_{IK}	DC Input Diode Current	- 50	mA
I_{OK}	DC Output Diode Current (note 2)	- 50	mA
I_O	DC Output Current	± 50	mA
I_{CC} or I_{GND}	DC V_{CC} or Ground Current per Supply Pin	± 100	mA
P_D	Power Dissipation	400	mW
T_{stg}	Storage Temperature	-65 to +150	$^{\circ}\text{C}$
T_L	Lead Temperature (10 sec)	300	$^{\circ}\text{C}$

Absolute Maximum Ratings are those values beyond which damage to the device may occur. Functional operation under these conditions is not implied

1) I_O absolute maximum rating must be observed

2) $V_O < \text{GND}$, $V_O > V_{CC}$

RECOMMENDED OPERATING CONDITIONS

Symbol	Parameter	Value	Unit
V_{CC}	Supply Voltage	1.8 to 3.6	V
V_I	Input Voltage	-0.3 to 3.6	V
V_O	Output Voltage (OFF State)	0 to 3.6	V
V_O	Output Voltage (High or Low State)	0 to V_{CC}	V
I_{OH} , I_{OL}	High or Low Level Output Current ($V_{CC} = 3.0$ to 3.6V)	± 24	mA
I_{OH} , I_{OL}	High or Low Level Output Current ($V_{CC} = 2.3$ to 2.7V)	± 18	mA
I_{OH} , I_{OL}	High or Low Level Output Current ($V_{CC} = 1.8\text{V}$)	± 6	mA
T_{op}	Operating Temperature	-55 to 125	$^{\circ}\text{C}$
dt/dv	Input Rise and Fall Time (note 1)	0 to 10	ns/V

1) V_{IN} from 0.8V to 2V at $V_{CC} = 3.0\text{V}$

74VCX16240

DC SPECIFICATIONS (2.7V < V_{CC} ≤ 3.6V unless otherwise specified)

Symbol	Parameter	Test Condition		Value				Unit
		V _{CC} (V)		-40 to 85 °C		-55 to 125 °C		
				Min.	Max.	Min.	Max.	
V _{IH}	High Level Input Voltage	2.7 to 3.6		2.0		2.0		V
V _{IL}	Low Level Input Voltage				0.8		0.8	
V _{OH}	High Level Output Voltage	2.7 to 3.6	I _O =-100 μA	V _{CC} -0.2		V _{CC} -0.2		V
		2.7	I _O =-12 mA	2.2		2.2		
		3.0	I _O =-18 mA	2.4		2.4		
			I _O =-24 mA	2.2		2.2		
V _{OL}	Low Level Output Voltage	2.7 to 3.6	I _O =100 μA		0.2		0.2	V
		2.7	I _O =12 mA		0.4		0.4	
		3.0	I _O =18 mA		0.4		0.4	
			I _O =24 mA		0.55		0.55	
I _I	Input Leakage Current	2.7 to 3.6	V _I = 0 to 3.6V		± 5		± 5	μA
I _{off}	Power Off Leakage Current	0	V _I or V _O = 0 to 3.6V		10		10	μA
I _{oz}	High Impedance Output Leakage Current	2.7 to 3.6	V _I = V _{IH} or V _{IL} V _O = 0 to 3.6V		± 10		± 10	μA
I _{CC}	Quiescent Supply Current	2.7 to 3.6	V _I = V _{CC} or GND		20		20	μA
			V _I or V _O = V _{CC} to 3.6V		± 20		± 20	
ΔI _{CC}	I _{CC} incr. per Input	2.7 to 3.6	V _{IH} = V _{CC} - 0.6V		750		750	μA

DC SPECIFICATIONS ($2.3V < V_{CC} \leq 2.7V$ unless otherwise specified)

Symbol	Parameter	Test Condition		Value				Unit
		V_{CC} (V)		-40 to 85 °C		-55 to 125 °C		
				Min.	Max.	Min.	Max.	
V_{IH}	High Level Input Voltage	2.3 to 2.7		1.6		1.6		V
V_{IL}	Low Level Input Voltage					0.7		
V_{OH}	High Level Output Voltage	2.3 to 2.7	$I_O = -100 \mu A$	$V_{CC} - 0.2$		$V_{CC} - 0.2$		V
			$I_O = -6 \text{ mA}$	2.0		2.0		
		2.3	$I_O = -12 \text{ mA}$	1.8		1.8		
			$I_O = -18 \text{ mA}$	1.7		1.7		
V_{OL}	Low Level Output Voltage	2.3 to 2.7	$I_O = 100 \mu A$		0.2		0.2	V
			$I_O = 12 \text{ mA}$		0.4		0.4	
		2.3	$I_O = 18 \text{ mA}$		0.6		0.6	
I_I	Input Leakage Current	2.3 to 2.7	$V_I = 0 \text{ to } 3.6V$		± 5		± 5	μA
I_{off}	Power Off Leakage Current	0	$V_I \text{ or } V_O = 0 \text{ to } 3.6V$		10		10	μA
I_{OZ}	High Impedance Output Leakage Current	2.3 to 2.7	$V_I = V_{IH} \text{ or } V_{IL}$ $V_O = 0 \text{ to } 3.6V$		± 10		± 10	μA
I_{CC}	Quiescent Supply Current	2.3 to 2.7	$V_I = V_{CC} \text{ or } GND$		20		20	μA
			$V_I \text{ or } V_O = V_{CC} \text{ to } 3.6V$		± 20		± 20	

DC SPECIFICATIONS ($1.8V \leq V_{CC} \leq 2.3V$ unless otherwise specified)

Symbol	Parameter	Test Condition		Value				Unit
		V_{CC} (V)		-40 to 85 °C		-55 to 125 °C		
				Min.	Max.	Min.	Max.	
V_{IH}	High Level Input Voltage	1.8 to 2.3		0.7 VCC		0.7 VCC		V
V_{IL}	Low Level Input Voltage					0.2 VCC		0.2 VCC
V_{OH}	High Level Output Voltage	1.8	$I_O = -100 \mu A$	$V_{CC} - 0.2$		$V_{CC} - 0.2$		V
			$I_O = -6 \text{ mA}$	1.4		1.4		
V_{OL}	Low Level Output Voltage	1.8	$I_O = 100 \mu A$		0.2		0.2	V
			$I_O = 6 \text{ mA}$		0.3		0.3	
I_I	Input Leakage Current	1.8	$V_I = 0 \text{ to } 3.6V$		± 5		± 5	μA
I_{off}	Power Off Leakage Current	0	$V_I \text{ or } V_O = 0 \text{ to } 3.6V$		10		10	μA
I_{OZ}	High Impedance Output Leakage Current	1.8	$V_I = V_{IH} \text{ or } V_{IL}$ $V_O = 0 \text{ to } 3.6V$		± 10		± 10	μA
I_{CC}	Quiescent Supply Current	1.8	$V_I = V_{CC} \text{ or } GND$		20		20	μA
			$V_I \text{ or } V_O = V_{CC} \text{ to } 3.6V$		± 20		± 20	

DYNAMIC SWITCHING CHARACTERISTICS ($T_a = 25^\circ\text{C}$, Input $t_r = t_f = 2.0\text{ns}$, $C_L = 30\text{pF}$, $R_L = 500\Omega$)

Symbol	Parameter	Test Condition		Value			Unit
		V_{CC} (V)		$T_A = 25^\circ\text{C}$			
				Min.	Typ.	Max.	
V_{OLP}	Dynamic Low Voltage Quiet Output (note 1, 3)	1.8	$V_{IL} = 0\text{V}$ $V_{IH} = V_{CC}$		0.25		V
		2.5			0.6		
		3.3			0.8		
V_{OLV}	Dynamic Low Voltage Quiet Output (note 1, 3)	1.8	$V_{IL} = 0\text{V}$ $V_{IH} = V_{CC}$		-0.25		V
		2.5			-0.6		
		3.3			-0.8		
V_{OHV}	Dynamic High Voltage Quiet Output (note 2, 3)	1.8	$V_{IL} = 0\text{V}$ $V_{IH} = V_{CC}$		1.5		V
		2.5			1.9		
		3.3			2.2		

1) Number of outputs defined as "n". Measured with "n-1" outputs switching from HIGH to LOW or LOW to HIGH. The remaining output is measured in the LOW state.

2) Number of outputs defined as "n". Measured with "n-1" outputs switching from HIGH to LOW or LOW to HIGH. The remaining output is measured in the HIGH state.

3) Parameters guaranteed by design.

AC ELECTRICAL CHARACTERISTICS ($C_L = 30\text{pF}$, $R_L = 500\Omega$, Input $t_r = t_f = 2.0\text{ns}$)

Symbol	Parameter	Test Condition		Value				Unit
		V_{CC} (V)		-40 to 85°C		-55 to 125°C		
				Min.	Max.	Min.	Max.	
t_{PLH} t_{PHL}	Propagation Delay Time	1.8		1.5	5.0	1.5	6.3	ns
		2.3 to 2.7		1.0	3.0	1.0	4.0	
		3.0 to 3.6		0.8	2.5	0.8	3.5	
t_{PZL} t_{PZH}	Output Enable Time	1.8		1.5	6.5	1.5	7.5	ns
		2.3 to 2.7		1.0	4.1	1.0	5.0	
		3.0 to 3.6		0.8	3.5	0.8	4.3	
t_{PLZ} t_{PHZ}	Output Disable Time	1.8		1.5	5.0	1.5	6.3	ns
		2.3 to 2.7		1.0	3.8	1.0	4.9	
		3.0 to 3.6		0.8	3.5	0.8	4.3	
t_{OSLH} t_{OSHL}	Output To Output Skew Time (note1, 2)	1.8			0.5		0.5	ns
		2.3 to 2.7			0.5		0.5	
		3.0 to 3.6			0.5		0.5	

1) Skew is defined as the absolute value of the difference between the actual propagation delay for any two outputs of the same device switching in the same direction, either HIGH or LOW ($t_{OSLH} = |t_{PLHm} - t_{PLHn}|$, $t_{OSHL} = |t_{PHLm} - t_{PHLn}|$)

2) Parameter guaranteed by design

CAPACITIVE CHARACTERISTICS

Symbol	Parameter	Test Condition		Value			Unit
		V _{CC} (V)		T _A = 25 °C			
				Min.	Typ.	Max.	
C _{IN}	Input Capacitance	1.8, 2.5 or 3.3	V _{IN} = 0 or V _{CC}		6		pF
C _{OUT}	Output Capacitance	1.8, 2.5 or 3.3	V _{IN} = 0 or V _{CC}		7		pF
C _{PD}	Power Dissipation Capacitance (note 1)	1.8, 2.5 or 3.3	f _{IN} = 10MHz V _{IN} = 0 or V _{CC}		20		pF

1) C_{PD} is defined as the value of the IC's internal equivalent capacitance which is calculated from the operating current consumption without load. (Refer to Test Circuit). Average operating current can be obtained by the following equation. $I_{CC(oper)} = C_{PD} \times V_{CC} \times f_{IN} + I_{CC}/16$ (per circuit)

TEST CIRCUIT

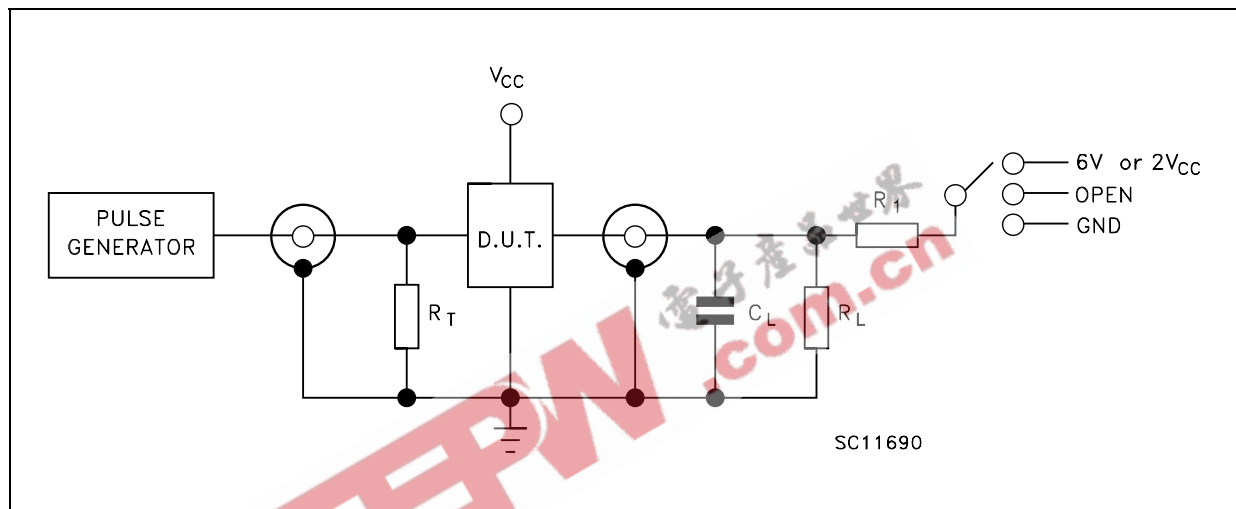

TEST	SWITCH
t _{PLH} , t _{PHL}	Open
t _{PZL} , t _{PLZ} (V _{CC} = 3.0 to 3.6V)	6V
t _{PZL} , t _{PLZ} (V _{CC} = 2.3 to 2.7V or 1.8V)	2V _{CC}
t _{PZH} , t _{PHZ}	GND

C_L = 30 pF or equivalent (includes jig and probe capacitance)
R_L = R₁ = 500Ω or equivalent
R_T = Z_{OUT} of pulse generator (typically 50Ω)

WAVEFORM SYMBOL VALUES

Symbol	V _{CC}		
	3.0 to 3.6V	2.3 to 2.7V	1.8V
V _{IH}	2.7V	V _{CC}	V _{CC}
V _M	1.5V	V _{CC} /2	V _{CC} /2
V _X	V _{OL} + 0.3V	V _{OL} + 0.15V	V _{OL} + 0.15V
V _Y	V _{OH} - 0.3V	V _{OH} - 0.15V	V _{OH} - 0.15V

WAVEFORM 1: PROPAGATION DELAYS (f=1MHz; 50% duty cycle)

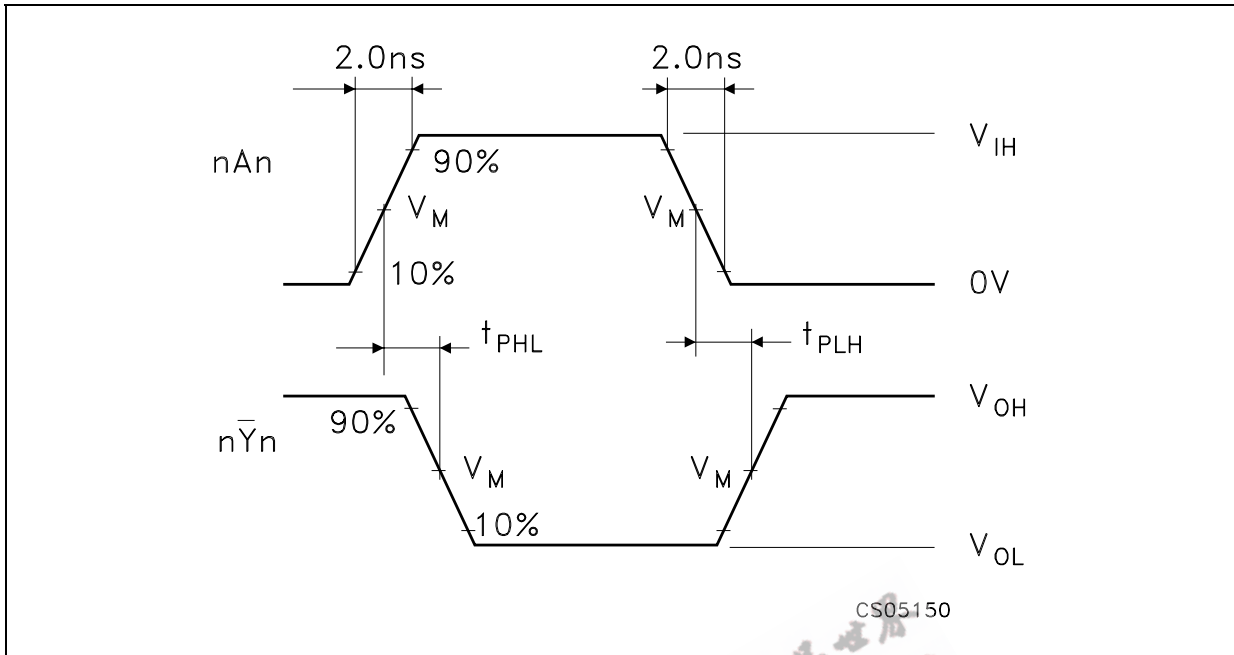

WAVEFORM 2: OUTPUT ENABLE AND DISABLE TIME (f=1MHz; 50% duty cycle)

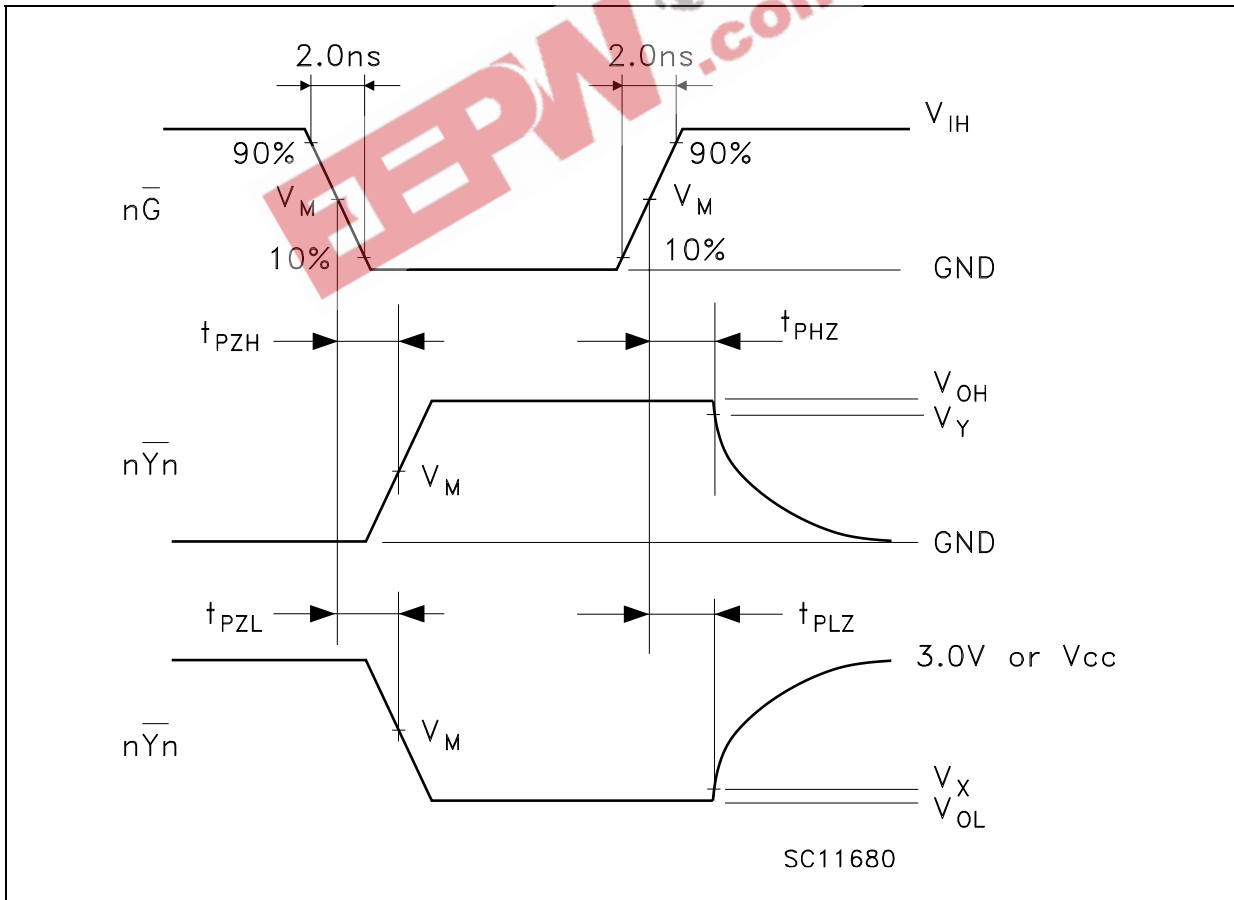

TSSOP48 MECHANICAL DATA

DIM.	mm.			inch		
	MIN.	TYP.	MAX.	MIN.	TYP.	MAX.
A			1.2			0.047
A1	0.05		0.15	0.002		0.006
A2		0.9			0.035	
b	0.17		0.27	0.0067		0.011
c	0.09		0.20	0.0035		0.0079
D	12.4		12.6	0.488		0.496
E		8.1 BSC			0.318 BSC	
E1	6.0		6.2	0.236		0.244
e		0.5 BSC			0.0197 BSC	
K	0°		8°	0°		8°
L	0.50		0.75	0.020		0.030

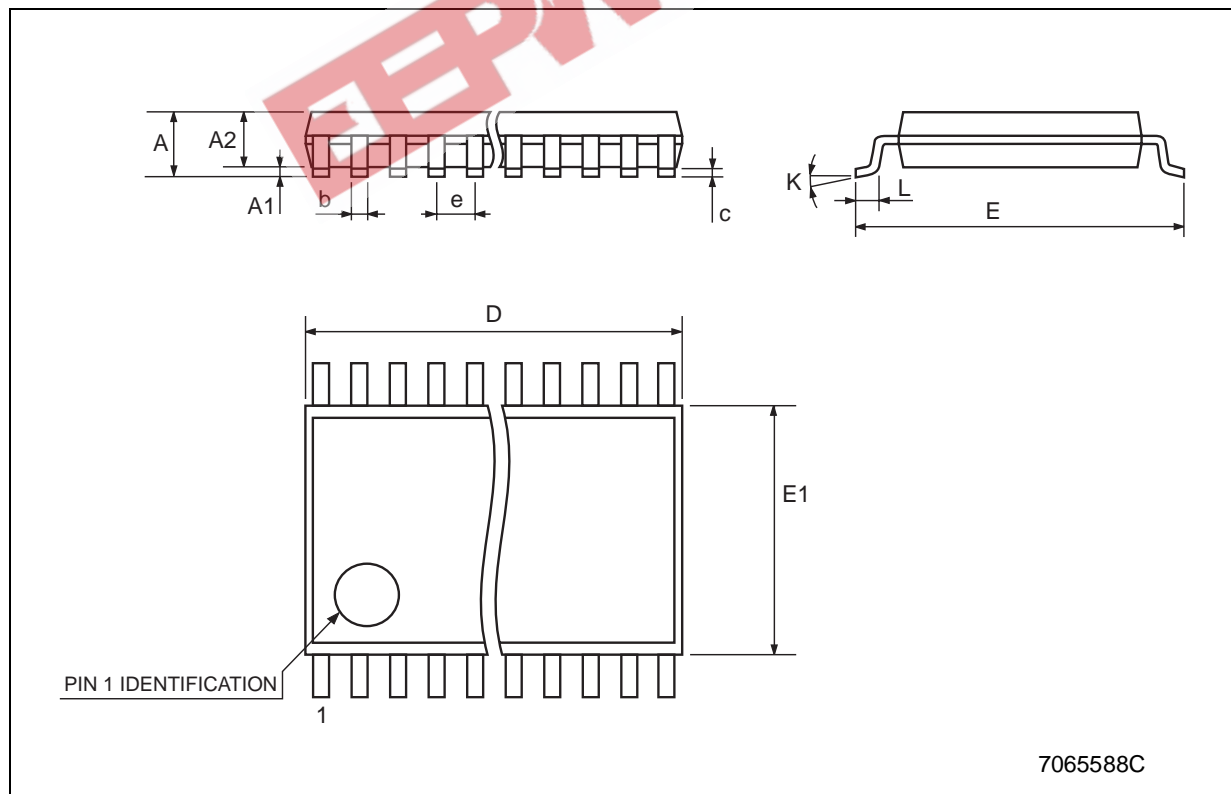

Tape & Reel TSSOP48 MECHANICAL DATA

DIM.	mm.			inch		
	MIN.	TYP	MAX.	MIN.	TYP.	MAX.
A			330			12.992
C	12.8		13.2	0.504		0.519
D	20.2			0.795		
N	60			2.362		
T			30.4			1.197
Ao	8.7		8.9	0.343		0.350
Bo	13.1		13.3	0.516		0.524
Ko	1.5		1.7	0.059		0.067
Po	3.9		4.1	0.153		0.161
P	11.9		12.1	0.468		0.476

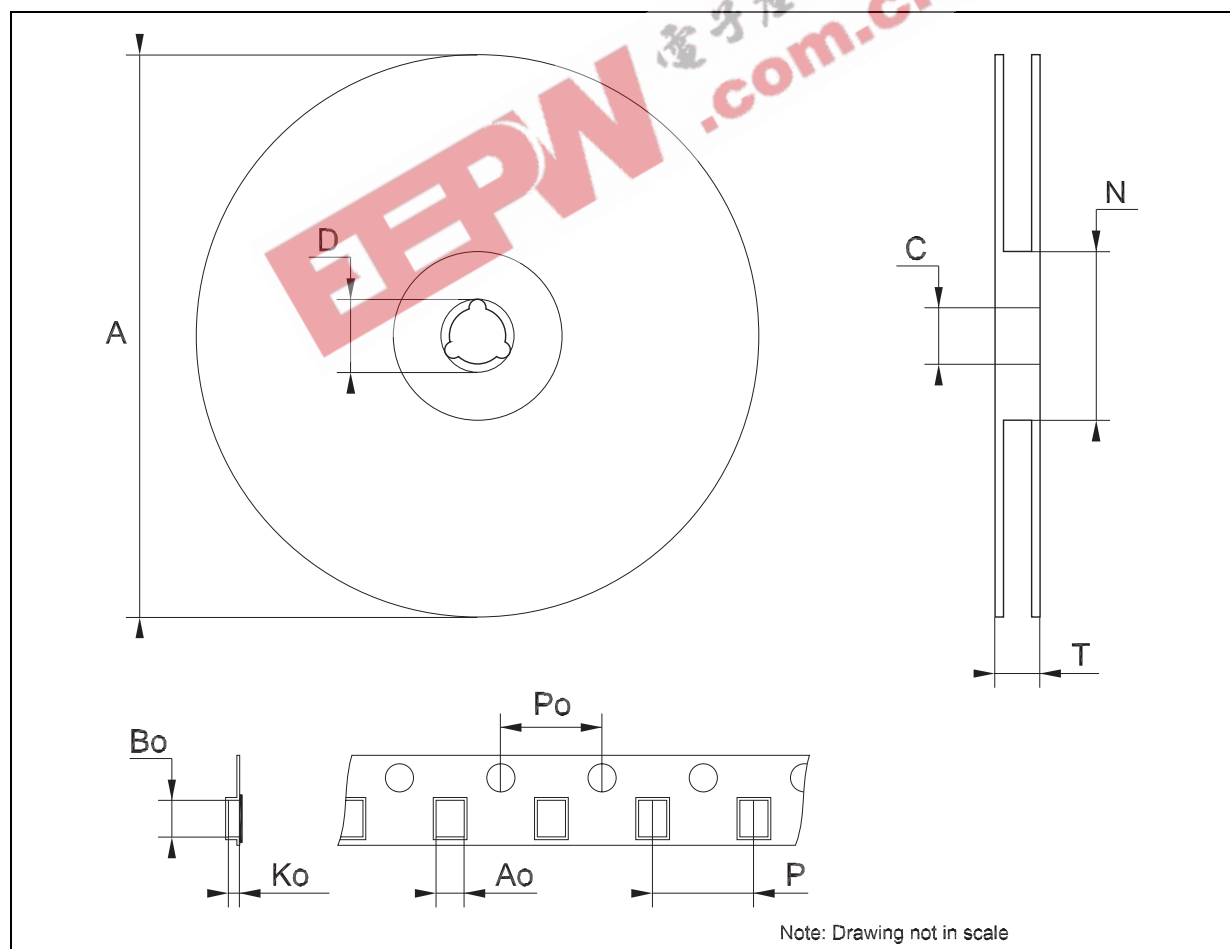

EEPW 电子产品世界
.com.cn

Information furnished is believed to be accurate and reliable. However, STMicroelectronics assumes no responsibility for the consequences of use of such information nor for any infringement of patents or other rights of third parties which may result from its use. No license is granted by implication or otherwise under any patent or patent rights of STMicroelectronics. Specifications mentioned in this publication are subject to change without notice. This publication supersedes and replaces all information previously supplied. STMicroelectronics products are not authorized for use as critical components in life support devices or systems without express written approval of STMicroelectronics.

© The ST logo is a registered trademark of STMicroelectronics

© 2003 STMicroelectronics - Printed in Italy - All Rights Reserved
STMicroelectronics GROUP OF COMPANIES

Australia - Brazil - Canada - China - Finland - France - Germany - Hong Kong - India - Israel - Italy - Japan - Malaysia - Malta - Morocco
Singapore - Spain - Sweden - Switzerland - United Kingdom - United States.

© <http://www.st.com>