

# DATA SHEET

For a complete data sheet, please also download:

- The IC06 74HC/HCT/HCU/HCMOS Logic Family Specifications
- The IC06 74HC/HCT/HCU/HCMOS Logic Package Information
- The IC06 74HC/HCT/HCU/HCMOS Logic Package Outlines

EEPW 电子产品世界  
.com.cn

## 74HC/HCT373

Octal D-type transparent latch;  
3-state

Product specification  
File under Integrated Circuits, IC06

September 1993

## Octal D-type transparent latch; 3-state

## 74HC/HCT373

## FEATURES

- 3-state non-inverting outputs for bus oriented applications
- Common 3-state output enable input
- Functionally identical to the "563", "573" and "533"
- Output capability: bus driver
- I<sub>CC</sub> category: MSI

## GENERAL DESCRIPTION

The 74HC/HCT373 are high-speed Si-gate CMOS devices and are pin compatible with low power Schottky TTL (LSTTL). They are specified in compliance with JEDEC standard no. 7A.

The 74HC/HCT373 are octal D-type transparent latches featuring separate D-type inputs for each latch and 3-state outputs for bus oriented applications. A latch enable (LE)

input and an output enable ( $\overline{OE}$ ) input are common to all latches.

The "373" consists of eight D-type transparent latches with 3-state true outputs. When LE is HIGH, data at the D<sub>n</sub> inputs enters the latches. In this condition the latches are transparent, i.e. a latch output will change state each time its corresponding D-input changes.

When LE is LOW the latches store the information that was present at the D-inputs a set-up time preceding the HIGH-to-LOW transition of LE. When  $\overline{OE}$  is LOW, the contents of the 8 latches are available at the outputs. When  $\overline{OE}$  is HIGH, the outputs go to the high impedance OFF-state. Operation of the  $\overline{OE}$  input does not affect the state of the latches.

The "373" is functionally identical to the "533", "563" and "573", but the "563" and "533" have inverted outputs and the "563" and "573" have a different pin arrangement.

## QUICK REFERENCE DATA

GND = 0 V; T<sub>amb</sub> = 25 °C; t<sub>r</sub> = t<sub>f</sub> = 6 ns

SYMBOL	PARAMETER	CONDITIONS	TYPICAL		UNIT
			HC	HCT	
t <sub>PHL</sub> / t <sub>PLH</sub>	propagation delay	C <sub>L</sub> = 15 pF; V <sub>CC</sub> = 5 V			
	D <sub>n</sub> to Q <sub>n</sub>		12	14	ns
	LE to Q <sub>n</sub>		15	13	ns
C <sub>I</sub>	input capacitance		3.5	3.5	pF
C <sub>PD</sub>	power dissipation capacitance per latch	notes 1 and 2	45	41	pF

## Notes

1. C<sub>PD</sub> is used to determine the dynamic power dissipation (P<sub>D</sub> in μW):

$$P_D = C_{PD} \times V_{CC}^2 \times f_i + \sum (C_L \times V_{CC}^2 \times f_o) \text{ where:}$$

f<sub>i</sub> = input frequency in MHz

f<sub>o</sub> = output frequency in MHz

∑ (C<sub>L</sub> × V<sub>CC</sub><sup>2</sup> × f<sub>o</sub>) = sum of outputs

C<sub>L</sub> = output load capacitance in pF

V<sub>CC</sub> = supply voltage in V

2. For HC the condition is V<sub>I</sub> = GND to V<sub>CC</sub>. For HCT the condition is V<sub>I</sub> = GND to V<sub>CC</sub> - 1.5 V

## ORDERING INFORMATION

See "74HC/HCT/HCU/HCMOS Logic Package Information".

Octal D-type transparent latch; 3-state

74HC/HCT373

PIN DESCRIPTION

PIN NO.	SYMBOL	NAME AND FUNCTION
1	$\overline{OE}$	3-state output enable input (active LOW)
2, 5, 6, 9, 12, 15, 16, 19	$Q_0$ to $Q_7$	3-state latch outputs
3, 4, 7, 8, 13, 14, 17, 18	$D_0$ to $D_7$	data inputs
10	GND	ground (0 V)
11	LE	latch enable input (active HIGH)
20	$V_{CC}$	positive supply voltage

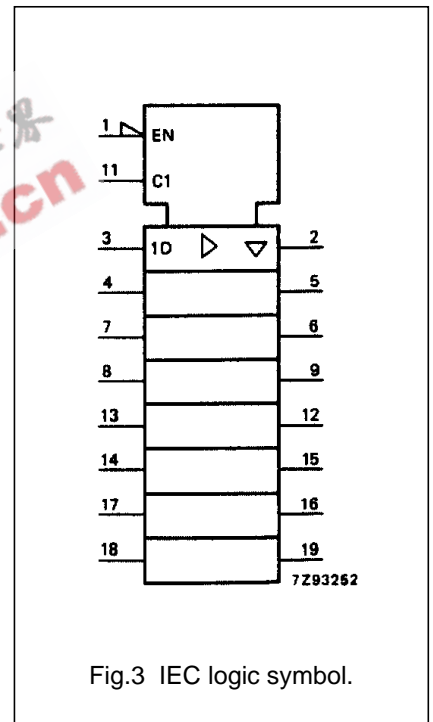
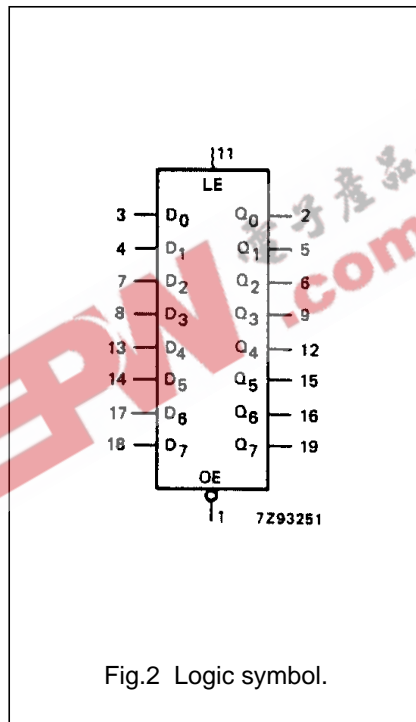
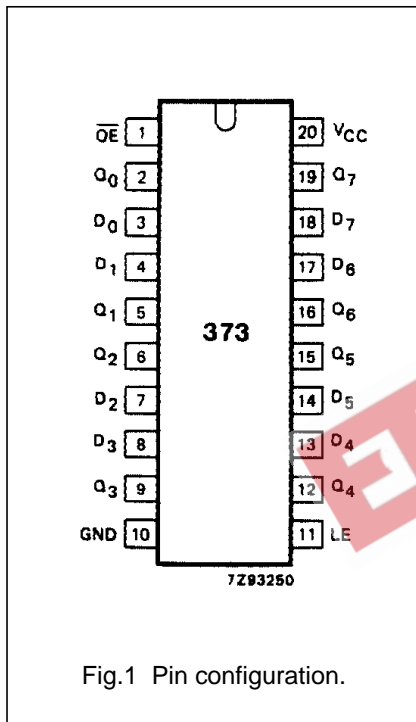

Octal D-type transparent latch; 3-state

74HC/HCT373

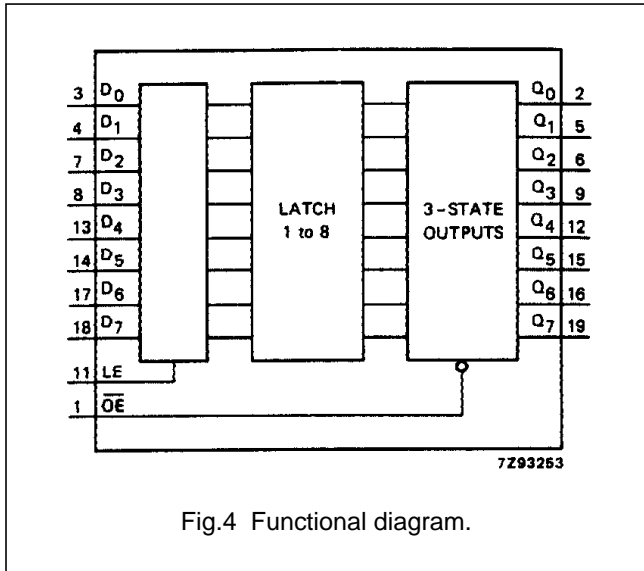

Fig.4 Functional diagram.

FUNCTION TABLE

OPERATING MODES	INPUTS			INTERNAL LATCHES	OUTPUTS Q <sub>0</sub> to Q <sub>7</sub>
	$\overline{OE}$	LE	D <sub>n</sub>		
enable and read register (transparent mode)	L	H	L	L	L
latch and read register	L	H	H	H	H
latch register	L	L	l	L	L
latch register and disable outputs	L	L	h	H	H
latch register and disable outputs	H	X	X	X	Z
latch register and disable outputs	H	X	X	X	Z

Notes

- 1. H = HIGH voltage level
- h = HIGH voltage level one set-up time prior to the HIGH-to-LOW LE transition
- L = LOW voltage level
- l = LOW voltage level one set-up time prior to the HIGH-to-LOW LE transition
- X = don't care
- Z = high impedance OFF-state

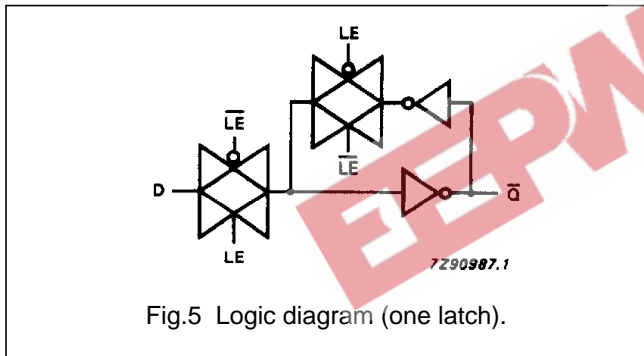

Fig.5 Logic diagram (one latch).

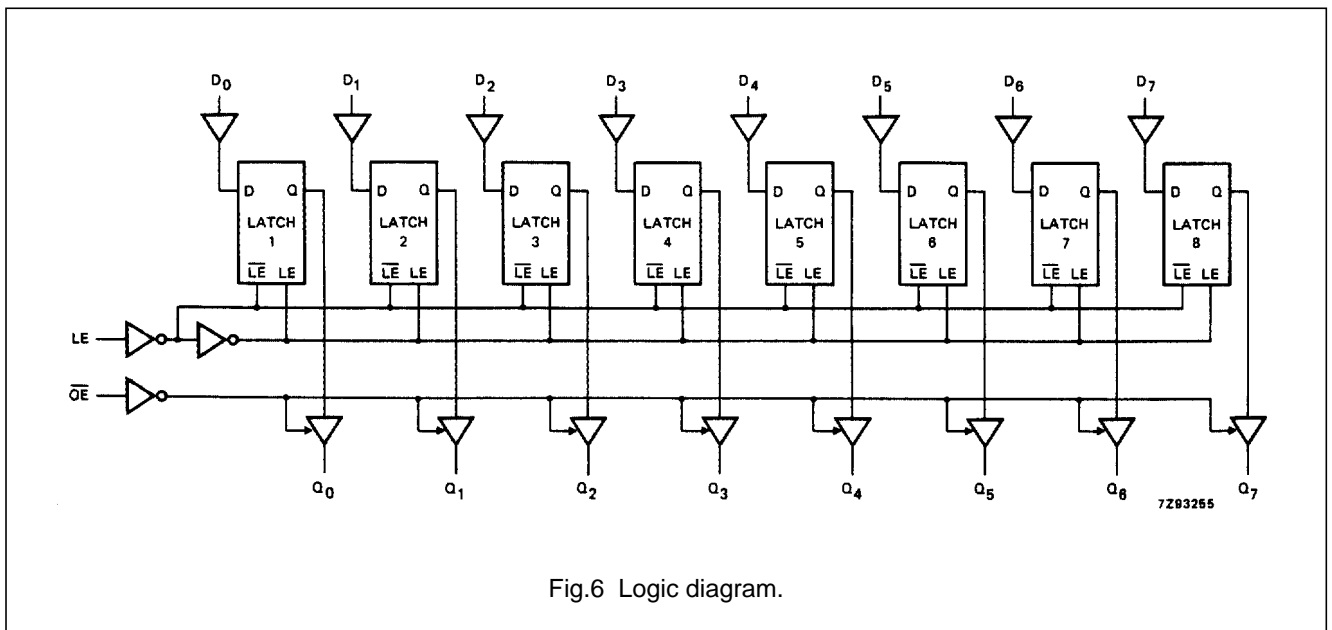

Fig.6 Logic diagram.

## Octal D-type transparent latch; 3-state

## 74HC/HCT373

**DC CHARACTERISTICS FOR 74HC**

For the DC characteristics see *"74HC/HCT/HCU/HCMOS Logic Family Specifications"*.

Output capability: bus driver

I<sub>CC</sub> category: MSI

**AC CHARACTERISTICS FOR 74HC**

GND = 0 V; t<sub>r</sub> = t<sub>f</sub> = 6 ns; C<sub>L</sub> = 50 pF

SYMBOL	PARAMETER	T <sub>amb</sub> (°C)						UNIT	TEST CONDITIONS		
		74HC							V <sub>CC</sub> (V)	WAVEFORMS	
		+25			-40 to +85		-40 to +125				
		min.	typ.	max.	min.	max.	min.				max.
t <sub>PHL</sub> / t <sub>PLH</sub>	propagation delay D <sub>n</sub> to Q <sub>n</sub>		41 15 12	150 30 26		190 38 33	225 45 38	ns	2.0 4.5 6.0	Fig.7	
t <sub>PHL</sub> / t <sub>PLH</sub>	propagation delay LE to Q <sub>n</sub>		50 18 14	175 35 30		220 44 37	265 53 45	ns	2.0 4.5 6.0	Fig.8	
t <sub>PZH</sub> / t <sub>PZL</sub>	3-state output enable time OE to Q <sub>n</sub>		44 16 13	150 30 26		190 38 33	225 45 38	ns	2.0 4.5 6.0	Fig.9	
t <sub>PHZ</sub> / t <sub>PLZ</sub>	3-state output disable time OE to Q <sub>n</sub>		47 17 14	150 30 26		190 38 33	225 45 38	ns	2.0 4.5 6.0	Fig.9	
t <sub>THL</sub> / t <sub>TLH</sub>	output transition time		14 5 4	60 12 10		75 15 13	90 18 15	ns	2.0 4.5 6.0	Fig.7	
t <sub>w</sub>	LE pulse width HIGH	80 16 14	17 6 5		100 20 17		120 24 20	ns	2.0 4.5 6.0	Fig.8	
t <sub>su</sub>	set-up time D <sub>n</sub> to LE	50 10 9	14 5 4		65 13 11		75 15 13	ns	2.0 4.5 6.0	Fig.10	
t <sub>h</sub>	hold time D <sub>n</sub> to LE	5 5 5	-8 -3 -2		5 5 5		5 5 5	ns	2.0 4.5 6.0	Fig.10	

## Octal D-type transparent latch; 3-state

## 74HC/HCT373

**DC CHARACTERISTICS FOR 74HCT**

For the DC characteristics see *"74HC/HCT/HCU/HCMOS Logic Family Specifications"*.

Output capability: bus driver

I<sub>CC</sub> category: MSI

**Note to HCT types**

The value of additional quiescent supply current ( $\Delta I_{CC}$ ) for a unit load of 1 is given in the family specifications. To determine  $\Delta I_{CC}$  per input, multiply this value by the unit load coefficient shown in the table below.

INPUT	UNIT LOAD COEFFICIENT
D <sub>n</sub>	0.30
LE	1.50
$\overline{OE}$	1.00

**AC CHARACTERISTICS FOR 74HCT**

GND = 0 V; t<sub>r</sub> = t<sub>f</sub> = 6 ns; C<sub>L</sub> = 50 pF

SYMBOL	PARAMETER	T <sub>amb</sub> (°C)						UNIT	TEST CONDITIONS		
		74HCT							V <sub>CC</sub> (V)	WAVEFORMS	
		+25			-40 to +85		-40 to +125				
		min.	typ.	max.	min.	max.	min.				max.
t <sub>PHL</sub> / t <sub>PLH</sub>	propagation delay D <sub>n</sub> to Q <sub>n</sub>		17	30		38		45	ns	4.5	Fig.7
t <sub>PHL</sub> / t <sub>PLH</sub>	propagation delay LE to Q <sub>n</sub>		16	32		40		48	ns	4.5	Fig.8
t <sub>PZH</sub> / t <sub>PZL</sub>	3-state output enable time $\overline{OE}$ to Q <sub>n</sub>		19	32		40		48	ns	4.5	Fig.9
t <sub>PHZ</sub> / t <sub>PLZ</sub>	3-state output disable time $\overline{OE}$ to Q <sub>n</sub>		18	30		38		45	ns	4.5	Fig.9
t <sub>THL</sub> / t <sub>TLH</sub>	output transition time		5	12		15		18	ns	4.5	Fig.7
t <sub>w</sub>	LE pulse width HIGH	16	4		20		24		ns	4.5	Fig.8
t <sub>su</sub>	set-up time D <sub>n</sub> to LE	12	6		15		18		ns	4.5	Fig.10
t <sub>h</sub>	hold time D <sub>n</sub> to LE	4	-1		4		4		ns	4.5	Fig.10

Octal D-type transparent latch; 3-state

74HC/HCT373

AC WAVEFORMS

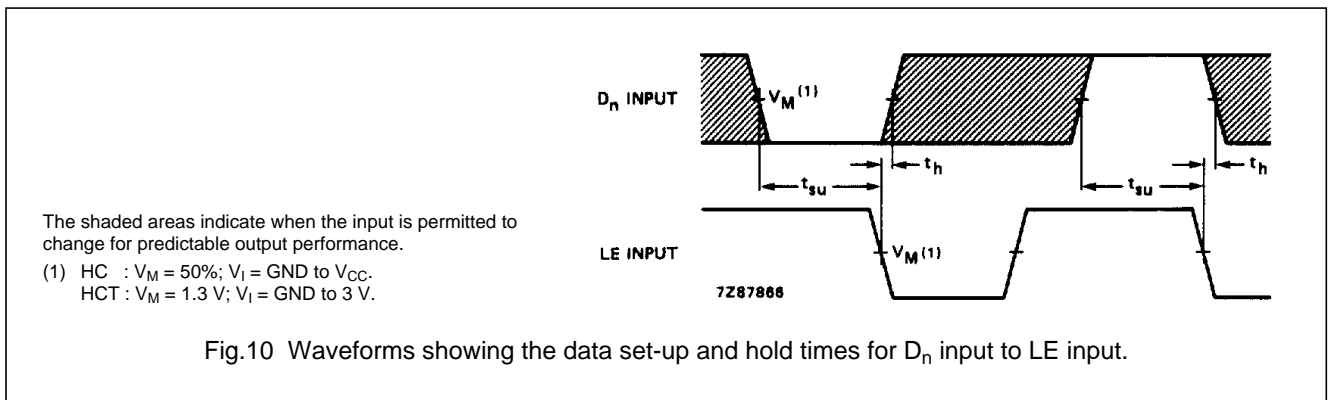
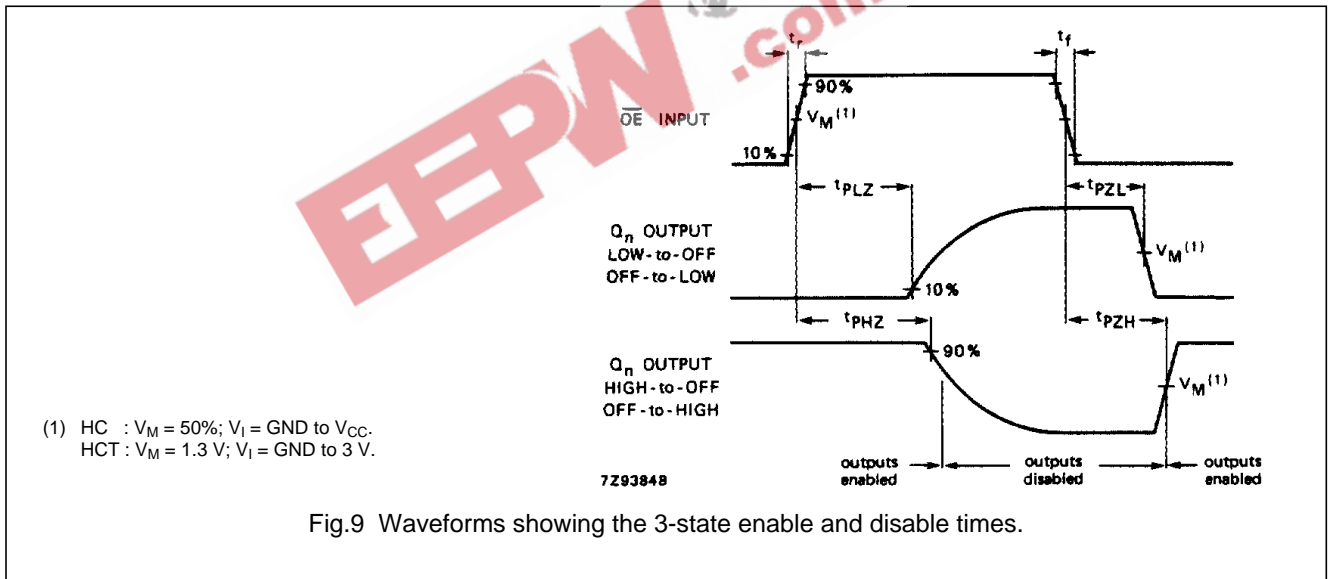
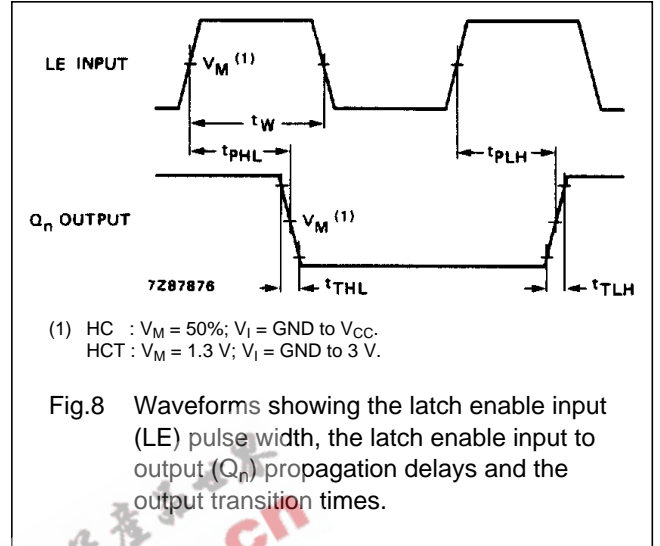
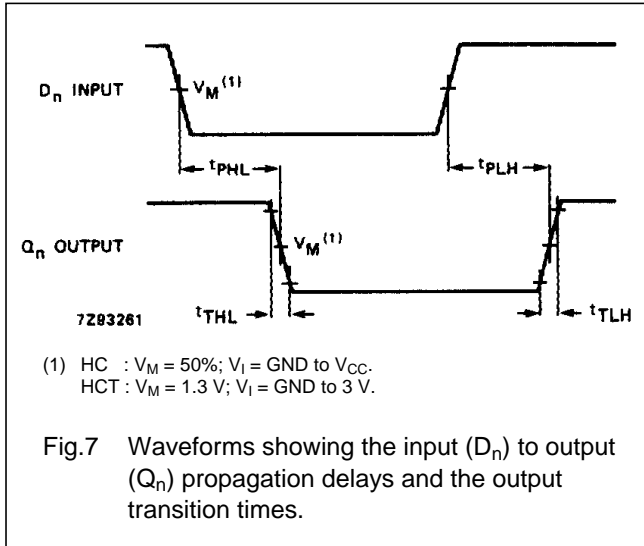

Octal D-type transparent latch; 3-state

74HC/HCT373

---

**PACKAGE OUTLINES**

See *"74HC/HCT/HCU/HCMOS Logic Package Outlines"*.

