

Octal transceiver/register, inverting (3-State)

74ABT651

FEATURES

- Independent registers for A and B buses
- The 74ABT651 is the inverting version of the 74ABT652
- Multiplexed real-time and stored data
- 3-State outputs
- Live insertion/extraction permitted.
- Power-up 3-State
- Power-up reset
- Output capability: +64mA/−32mA
- Latch-up protection exceeds 500mA per Jedec Std 17
- ESD protection exceeds 2000 V per MIL STD 883 Method 3015 and 200 V per Machine Model

DESCRIPTION

The 74ABT651 high-performance BiCMOS device combines low static and dynamic power dissipation with high speed and high output drive.

The 74ABT651 transceiver/register consists of bus transceiver circuits with 3-State outputs, D-type flip-flops, and control circuitry arranged for multiplexed transmission of data directly from the input bus or the internal registers. Data on the A or B bus will be clocked into the registers as the appropriate clock pin goes High. Output Enable (OEAB, $\overline{\text{OEBA}}$) and Select (SAB, SBA) pins are provided for bus management.

The following examples demonstrate the four fundamental bus-management functions that can be performed with the 74ABT651.

The select pins determine whether data is stored or transferred through the device in real time.

The output enable pins determine the direction of the data flow.

QUICK REFERENCE DATA

SYMBOL	PARAMETER	CONDITIONS $T_{\text{amb}} = 25^{\circ}\text{C}; \text{GND} = 0\text{V}$	TYPICAL	UNIT
t_{PLH} t_{PHL}	Propagation delay CPBA to An or CPAB to Bn	$C_L = 50\text{pF}; V_{\text{CC}} = 5\text{V}$	3.8 4.4	ns
C_{IN}	Input capacitance	$V_I = 0\text{V}$ or V_{CC}	4	pF
$C_{\text{I/O}}$	I/O capacitance	Outputs disabled; $V_O = 0\text{V}$ or V_{CC}	7	pF
I_{CCZ}	Total supply current	Outputs disabled; $V_{\text{CC}} = 5.5\text{V}$	110	μA

ORDERING INFORMATION

PACKAGES	TEMPERATURE RANGE	OUTSIDE NORTH AMERICA	NORTH AMERICA	DWG NUMBER
24-Pin Plastic DIP	−40°C to +85°C	74ABT651 N	74ABT651 N	SOT222-1
24-Pin plastic SO	−40°C to +85°C	74ABT651 D	74ABT651 D	SOT137-1
24-Pin Plastic SSOP Type II	−40°C to +85°C	74ABT651 DB	74ABT651 DB	SOT340-1
24-Pin Plastic TSSOP Type I	−40°C to +85°C	74ABT651 PW	74ABT651PW DH	SOT355-1

PIN CONFIGURATION

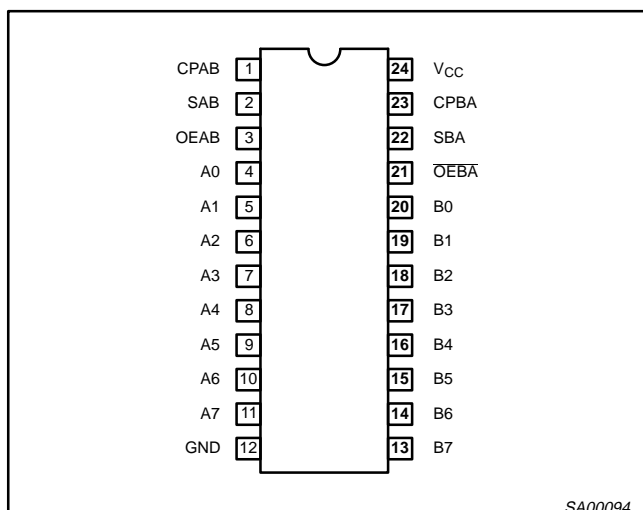

PIN DESCRIPTION

PIN NUMBER	SYMBOL	FUNCTION
1, 23	CPAB / CPBA	A to B clock input / B to A clock input
2, 22	SAB / SBA	A to B select input / B to A select input
3, 21	OEAB / $\overline{\text{OEBA}}$	A to B Output Enable input / B to A Output Enable input (active-Low)
4, 5, 6, 7, 8, 9, 10, 11	A0 – A7	Data inputs/outputs (A side)
20, 19, 18, 17, 16, 15, 14, 13	B0 – B7	Data inputs/outputs (B side)
12	GND	Ground (0V)
24	V_{CC}	Positive supply voltage

Octal transceiver/register, inverting (3-State)

74ABT651

LOGIC SYMBOL (IEEE/IEC)

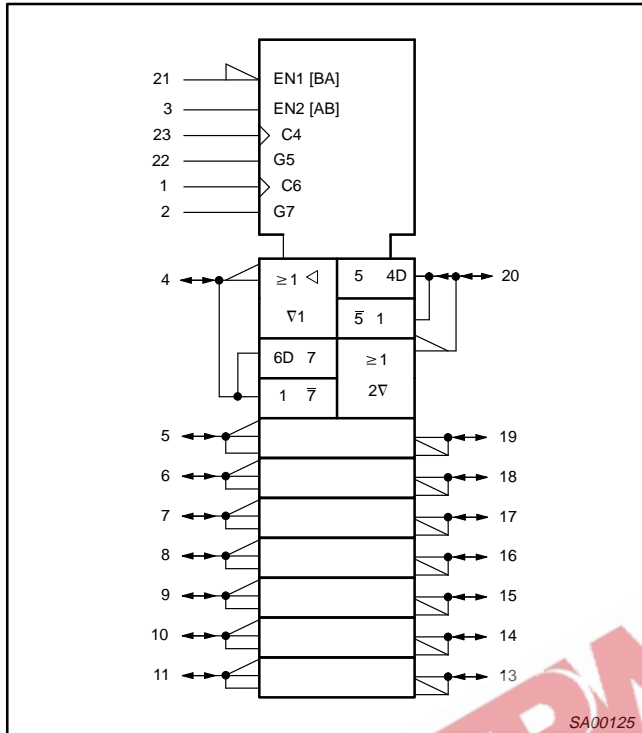

LOGIC SYMBOL

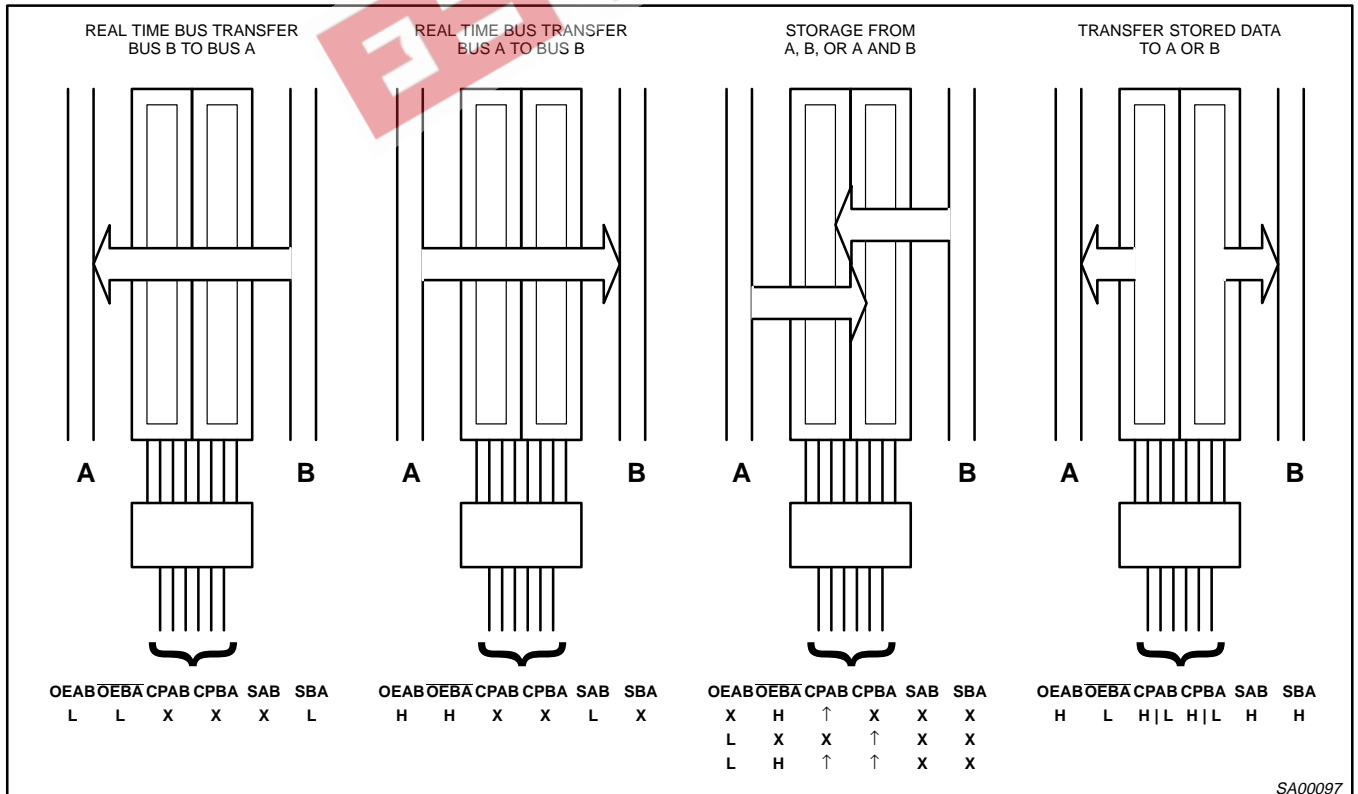
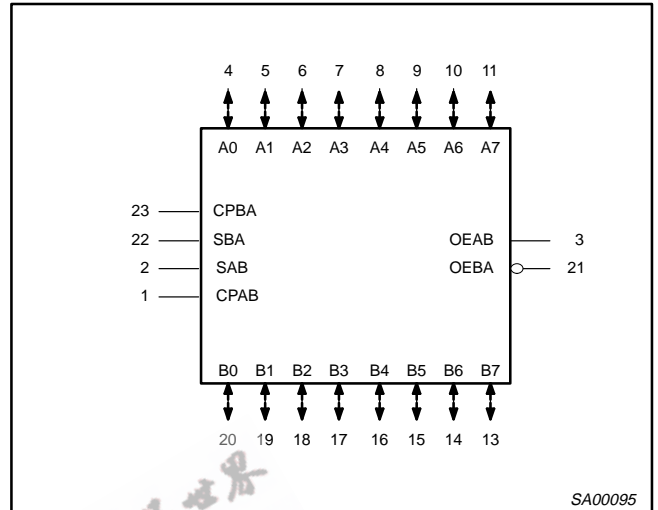

Octal transceiver/register, inverting (3-State)

74ABT651

FUNCTION TABLE

INPUTS						DATA I/O		OPERATING MODE
OEAB	OEBA	CPAB	CPBA	SAB	SBA	An	Bn	
L L	H H	H or L ↑	H or L ↑	X X	X X	Input	Input	Isolation Store A and B data
X H	H H	↑ ↑	H or L ↑	X **	X X	Input	Unspecified output*	Store A, Hold B Store A in both registers
L L	X L	H or L ↑	↑ ↑	X X	X **	Unspecified output*	Input	Hold A, Store B Store B in both registers
L L	L L	X X	X H or L	X X	L H	Output	Input	Real time \bar{B} data to A bus Stored \bar{B} data to A bus
H H	H H	X H or L	X X	L H	X X	Input	Output	Real time \bar{A} data to B bus Store \bar{A} data to B bus
H	L	H or L	H or L	H	H	Output	Output	Stored \bar{A} data to B bus Stored \bar{B} data to A bus

H = High voltage level
L = Low voltage level
X = Don't care
↑ = Low-to-High clock transition

* The data output function may be enabled or disabled by various signals at the OEBA and OEAB inputs. Data input functions are always enabled, i.e., data at the bus pins will be stored on every Low-to-High transition of the clock.
** If both Select controls (SAB and SBA) are Low, then clocks can occur simultaneously. If either Select control is High, the clocks must be staggered in order to load both registers.

LOGIC DIAGRAM

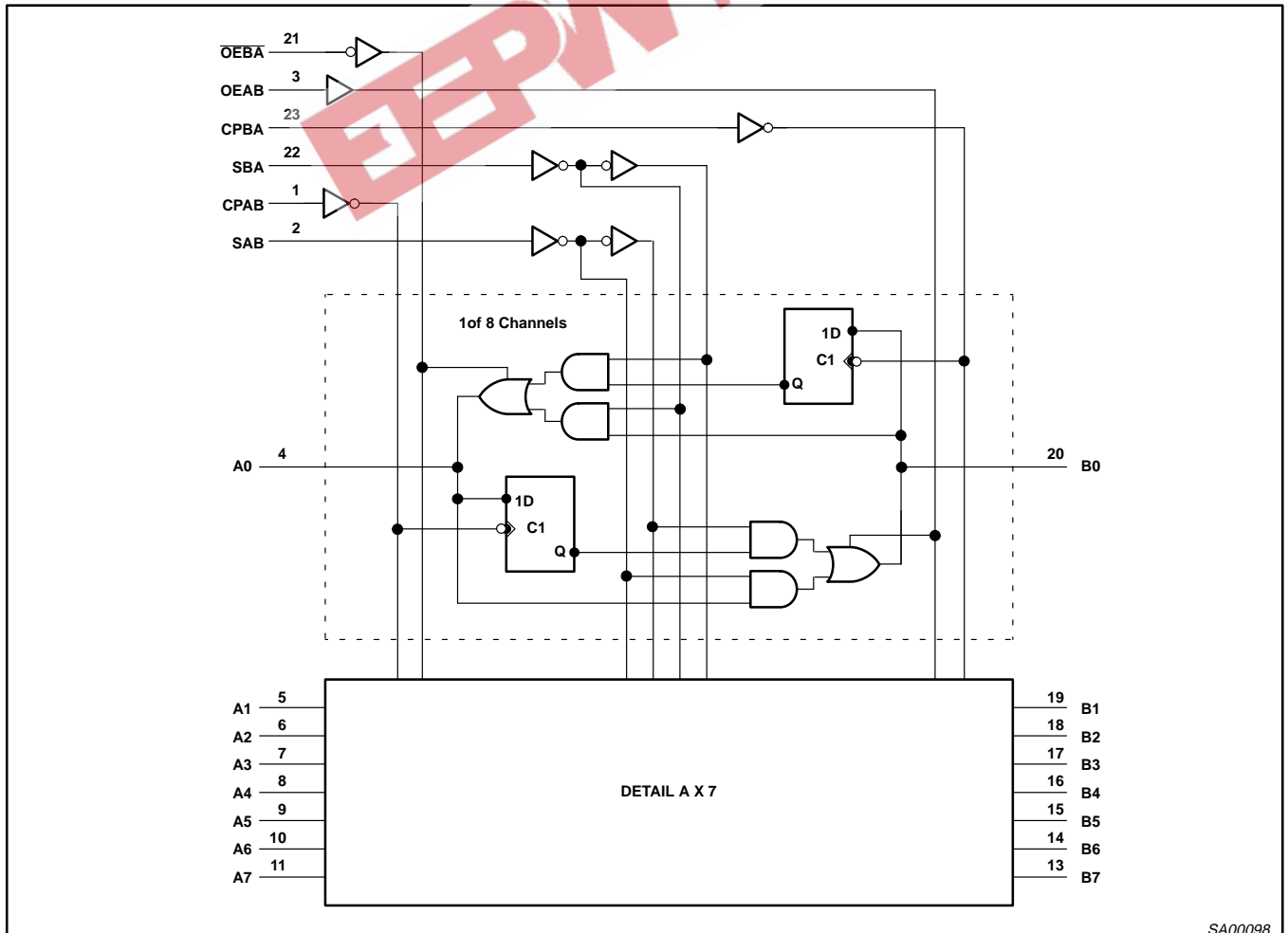

SA00098

Octal transceiver/register, inverting (3-State)

74ABT651

ABSOLUTE MAXIMUM RATINGS^{1, 2}

SYMBOL	PARAMETER	CONDITIONS	RATING	UNIT
V_{CC}	DC supply voltage		-0.5 to +7.0	V
I_{IK}	DC input diode current	$V_I < 0$	-18	mA
V_I	DC input voltage ³		-1.2 to +7.0	V
I_{OK}	DC output diode current	$V_O < 0$	-50	mA
V_{OUT}	DC output voltage ³	output in Off or High state	-0.5 to +5.5	V
I_{OUT}	DC output current	output in Low state	128	mA
T_{stg}	Storage temperature range		-65 to 150	°C

NOTES:

1. Stresses beyond those listed may cause permanent damage to the device. These are stress ratings only and functional operation of the device at these or any other conditions beyond those indicated under "recommended operating conditions" is not implied. Exposure to absolute-maximum-rated conditions for extended periods may affect device reliability.
2. The performance capability of a high-performance integrated circuit in conjunction with its thermal environment can create junction temperatures which are detrimental to reliability. The maximum junction temperature of this integrated circuit should not exceed 150°C.
3. The input and output voltage ratings may be exceeded if the input and output current ratings are observed.

RECOMMENDED OPERATING CONDITIONS

SYMBOL	PARAMETER	LIMITS		UNIT
		Min	Max	
V_{CC}	DC supply voltage	4.5	5.5	V
V_I	Input voltage	0	V_{CC}	V
V_{IH}	High-level input voltage	2.0		V
V_{IL}	Low-level Input voltage		0.8	V
I_{OH}	High-level output current		-32	mA
I_{OL}	Low-level output current		64	mA
$\Delta t/\Delta v$	Input transition rise or fall rate	0	10	ns/V
T_{amb}	Operating free-air temperature range	-40	+85	°C

Octal transceiver/register, inverting (3-State)

74ABT651

DC ELECTRICAL CHARACTERISTICS

SYMBOL	PARAMETER	TEST CONDITIONS	LIMITS					UNIT
			T _{amb} = +25°C			T _{amb} = -40°C to +85°C		
			Min	Typ	Max	Min	Max	
V _{IK}	Input clamp voltage	V _{CC} = 4.5V; I _{IK} = -18mA		-0.9	-1.2		-1.2	V
V _{OH}	High-level output voltage	V _{CC} = 4.5V; I _{OH} = -3mA; V _I = V _{IL} or V _{IH}	2.5	3.2		2.5		V
		V _{CC} = 5.0V; I _{OH} = -3mA; V _I = V _{IL} or V _{IH}	3.0	3.7		3.0		V
		V _{CC} = 4.5V; I _{OH} = -32mA; V _I = V _{IL} or V _{IH}	2.0	2.30		2.0		V
V _{OL}	Low-level output voltage	V _{CC} = 4.5V; I _{OL} = 64mA; V _I = V _{IL} or V _{IH}		0.42	0.55		0.55	V
V _{RST} ³	Power-up output low voltage	V _{CC} = 5.5V; I _O = 1mA; V _I = GND or V _{CC}		0.13	0.55		0.55	V
I _I	Input leakage current	Control pins	V _{CC} = 5.5V; V _I = GND or 5.5V		±0.01	±1.0	±1.0	μA
		Data pins	V _{CC} = 5.5V; V _I = GND or 5.5V		±5	±100	±100	μA
I _{OFF}	Power-off leakage current	V _{CC} = 0.0V; V _O or V _I ≤ 4.5V		±5.0	±100		±100	μA
I _{PU} /I _{PD}	Power-up/down 3-State output current ⁴	V _{CC} = 2.1V; V _O = 0.5V; V _{OE} = Don't Care; V _I = GND or V _{CC}		±5.0	±50		±50	μA
I _{IH} + I _{OZH}	3-State output High current	V _{CC} = 5.5V; V _O = 2.7V; V _I = V _{IL} or V _{IH}		5.0	50		50	μA
I _{IL} + I _{OZL}	3-State output Low current	V _{CC} = 5.5V; V _O = 0.5V; V _I = V _{IL} or V _{IH}		-5.0	-50		-50	μA
I _{CEx}	Output High leakage current	V _{CC} = 5.5V; V _O = 5.5V; V _I = GND or V _{CC}		5.0	50		50	μA
I _O	Output current ¹	V _{CC} = 5.5V; V _O = 2.5V	-40	-65	-180	-40	-180	mA
I _{CCH}	Quiescent supply current	V _{CC} = 5.5V; Outputs High, V _I = GND or V _{CC}		110	250		250	μA
I _{CCL}		V _{CC} = 5.5V; Outputs Low, V _I = GND or V _{CC}		20	30		30	mA
I _{CCZ}		V _{CC} = 5.5V; Outputs 3-State; V _I = GND or V _{CC}		110	250		250	μA
ΔI _{CC}	Additional supply current per input pin ²	V _{CC} = 5.5V; one input at 3.4V, other inputs at V _{CC} or GND; V _{CC} = 5.5V		0.3	1.5		1.5	mA

NOTES:

- Not more than one output should be tested at a time, and the duration of the test should not exceed one second.
- This is the increase in supply current for each input at 3.4V.
- For valid test results, data must not be loaded into the flip-flops (or latches) after applying the power.
- This parameter is valid for any V_{CC} between 0V and 2.1V, with a transition time of up to 10msec. From V_{CC} = 2.1V to V_{CC} = 5V ± 10%, a transition time of up to 100μsec is permitted.

AC CHARACTERISTICS

GND = 0V, t_R = t_F = 2.5ns, C_L = 50pF, R_L = 500Ω

SYMBOL	PARAMETER	WAVEFORM	LIMITS					UNIT
			T _{amb} = +25°C V _{CC} = +5.0V			T _{amb} = -40 to +85°C V _{CC} = +5.0V ± 0.5V		
			Min	Typ	Max	Min	Max	
f _{MAX}	Maximum clock frequency	1	125	300		125		MHz
t _{PLH} t _{PHL}	Propagation delay CPAB to Bn or CPBA to An	1	2.2	3.8	5.1	2.2	5.6	ns
			1.7	4.4	5.1	1.7	5.6	
t _{PLH} t _{PHL}	Propagation delay An to Bn or Bn to An	2	1.5	3.2	5.1	1.5	6.2	ns
			1.5	3.7	4.6	1.5	5.4	
t _{PLH} t _{PHL}	Propagation delay SAB to Bn or SBA to An	3	1.5	3.8	5.1	1.5	6.5	ns
			1.5	4.4	4.9	1.5	5.9	
t _{PZH} t _{PZL}	Output enable time OEBA to An	5	1.3	3.7	4.6	1.3	5.8	ns
			2.5	4.7	6.8	2.5	8.5	
t _{PHZ} t _{PLZ}	Output disable time OEBA to An	5	1.5	4.0	4.5	1.5	5.0	ns
			1.5	3.2	3.8	1.5	4.1	
t _{PZH} t _{PZL}	Output enable time OEAB to Bn	5	1.8	3.4	6.1	1.8	6.5	ns
			2.9	4.5	6.5	2.9	7.4	
t _{PHZ} t _{PLZ}	Output disable time OEAB to Bn	5	1.5	3.8	4.5	1.5	5.5	ns
			1.5	3.1	4.4	1.5	5.1	

Octal transceiver/register, inverting (3-State)

74ABT651

AC SETUP REQUIREMENTS

GND = 0V, $t_R = t_F = 2.5\text{ns}$, $C_L = 50\text{pF}$, $R_L = 500\Omega$

SYMBOL	PARAMETER	WAVEFORM	LIMITS			UNIT
			$T_{\text{amb}} = +25^\circ\text{C}$ $V_{\text{CC}} = +5.0\text{V}$		$T_{\text{amb}} = -40 \text{ to } +85^\circ\text{C}$ $V_{\text{CC}} = +5.0\text{V} \pm 0.5\text{V}$	
			Min	Typ	Min	
$t_{s(H)}$ $t_{s(L)}$	Setup time An to CPAB, Bn to CPBA	4	3.0 3.0	1.2 0.8	3.0 3.0	ns
$t_h(H)$ $t_h(L)$	Hold time An to CPAB, Bn to CPBA	4	0.0 0.0	-0.8 -0.9	0.0 0.0	ns
$t_w(H)$ $t_w(L)$	Pulse width, High or Low CPAB or CPBA	1	4.0 4.0	1.2 1.1	4.0 4.0	ns

AC WAVEFORMS

$V_M = 1.5\text{V}$, $V_{\text{IN}} = \text{GND to } 3.0\text{V}$

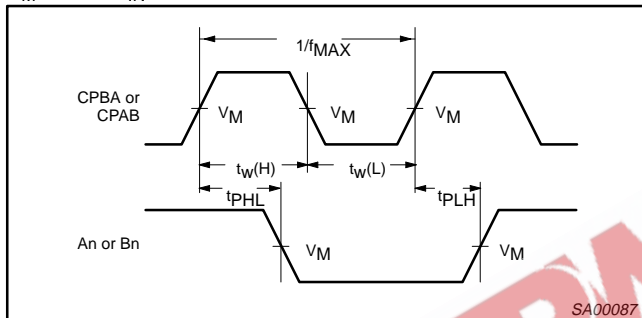

Waveform 1. Propagation Delay, Clock Input to Output, Clock Pulse Width, and Maximum Clock Frequency

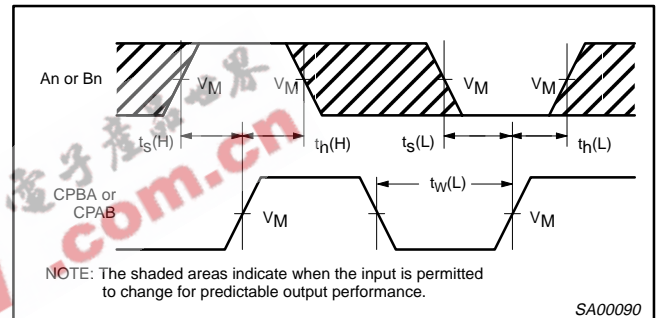

Waveform 4. Data Setup and Hold Times

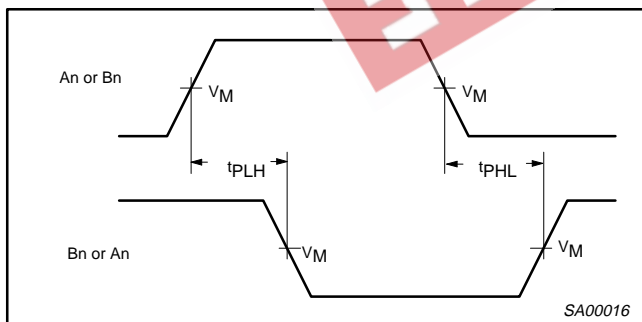

Waveform 2. Propagation Delay, An to Bn or Bn to An

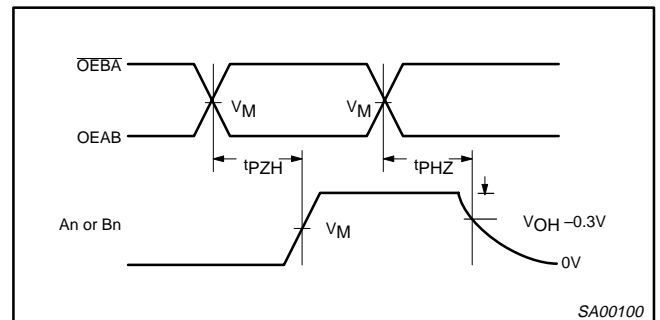

Waveform 5. 3-State Output Enable Time to High Level and Output Disable Time from High Level

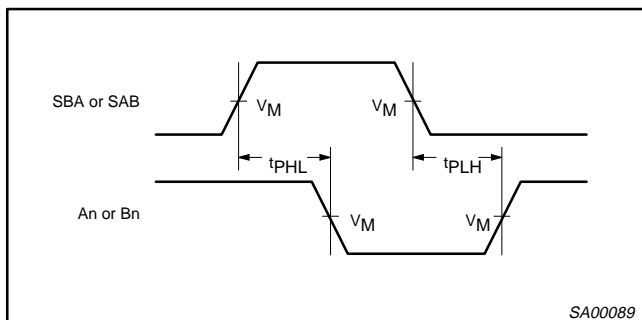

Waveform 3. Propagation Delay, SBA to An or SAB to Bn

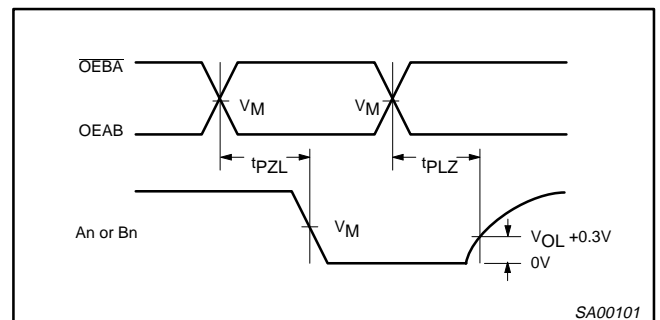

Waveform 6. 3-State Output Enable Time to Low Level and Output Disable Time from Low Level

Octal transceiver/register, inverting (3-State)

74ABT651

TEST CIRCUIT AND WAVEFORM

Test Circuit for 3-State Outputs

SWITCH POSITION

TEST	SWITCH
t_{PLZ}	closed
t_{PZL}	closed
All other	open

DEFINITIONS

R_L = Load resistor; see AC CHARACTERISTICS for value.
 C_L = Load capacitance includes jig and probe capacitance; see AC CHARACTERISTICS for value.
 R_T = Termination resistance should be equal to Z_{OUT} of pulse generators.

Input Pulse Definition

$V_M = 1.5V$

INPUT PULSE REQUIREMENTS					
FAMILY	Amplitude	Rep. Rate	t_W	t_R	t_F
74ABT	3.0V	1MHz	500ns	2.5ns	2.5ns

SA00012