

DATA SHEET

EEPW 电子產品世界
.com.cn

74ABT2245

Octal transceiver with direction pin with
30Ω series termination resistors (3-State)

Product specification
Supersedes data of 1996 Sep 10
IC23 Data Handbook

1998 Jan 16

Octal transceiver with direction pin and 30Ω series termination resistors (3-State)

74ABT2245

FEATURES

- Octal bidirectional bus interface
- 3-State buffers
- Output capability: +12mA/−32mA
- Latch-up protection exceeds 500mA per Jedec Std 17
- ESD protection exceeds 2000 V per MIL STD 833 Method 3015 and 200 V per Machine Model
- Power-up 3-State
- Live insertion/extraction permitted
- Same as 74ABT245-1
- Outputs include series resistance of 30Ω, making external termination resistors unnecessary
- Inputs are disabled during 3-State mode

DESCRIPTION

The 74ABT2245 high-performance BiCMOS device combines low static and dynamic power dissipation with high speed.

The 74ABT2245 device is an octal transceiver featuring non-inverting 3-State bus compatible outputs in both send and receive directions. The control function implementation minimizes external timing requirements. The device features an Output Enable (\overline{OE}) input for easy cascading and a Direction (DIR) input for direction control.

The 74ABT2245 is designed with 30Ω series resistance in both the High and Low states of the output. This design reduces line noise in applications such as memory address drivers, clock drivers, and bus receivers/transmitters.

The 74ABT2245 is the same as the 74ABT245-1. The part number has been changed to reflect industry standards.

QUICK REFERENCE DATA

| SYMBOL | PARAMETER | CONDITIONS $T_{amb} = 25^{\circ}\text{C}; \text{GND} = 0\text{V}$ | TYPICAL | UNIT |
|------------------------|---|--|---------|---------------|
| t_{PLH} t_{PHL} | Propagation delay An to Bn or Bn to An | $C_L = 50\text{pF}; V_{CC} = 5\text{V}$ | 3.9 | ns |
| C_{IN} | Input capacitance DIR, \overline{OE} | $V_I = 0\text{V}$ or V_{CC} | 4 | pF |
| $C_{I/O}$ | I/O pin capacitance | Outputs disabled; $V_O = 0\text{V}$ or V_{CC} | 7 | pF |
| I_{CCZ} | Total supply current | Outputs disabled; $V_{CC} = 5.5\text{V}$ | 50 | μA |

ORDERING INFORMATION

| PACKAGES | TEMPERATURE RANGE | OUTSIDE NORTH AMERICA | NORTH AMERICA | DWG NUMBER |
|-----------------------------|-------------------|-----------------------|----------------|------------|
| 20-Pin Plastic DIP | −40°C to +85°C | 74ABT2245 N | 74ABT2245 N | SOT146-1 |
| 20-Pin plastic SO | −40°C to +85°C | 74ABT2245 D | 74ABT2245 D | SOT163-1 |
| 20-Pin Plastic SSOP Type II | −40°C to +85°C | 74ABT2245 DB | 74ABT2245 DB | SOT339-1 |
| 20-Pin Plastic TSSOP Type I | −40°C to +85°C | 74ABT2245 PW | 74ABT2245PW DH | SOT360-1 |

PIN CONFIGURATION

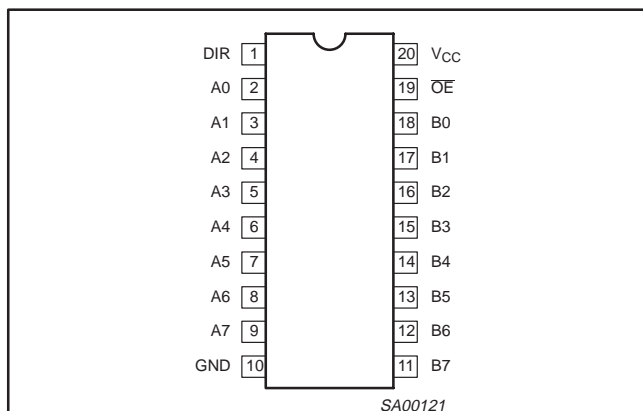

PIN DESCRIPTION

| PIN NUMBER | SYMBOL | NAME AND FUNCTION |
|--------------------------------|-----------------|----------------------------------|
| 1 | DIR | Direction control input |
| 2, 3, 4, 5, 6, 7, 8, 9 | A0 – A7 | Data inputs/outputs (A side) |
| 18, 17, 16, 15, 14, 13, 12, 11 | B0 – B7 | Data inputs/outputs (B side) |
| 19 | \overline{OE} | Output enable input (active-Low) |
| 10 | GND | Ground (0V) |
| 20 | V_{CC} | Positive supply voltage |

Octal transceiver with direction pin and 30Ω series termination resistors (3-State)

74ABT2245

LOGIC SYMBOL

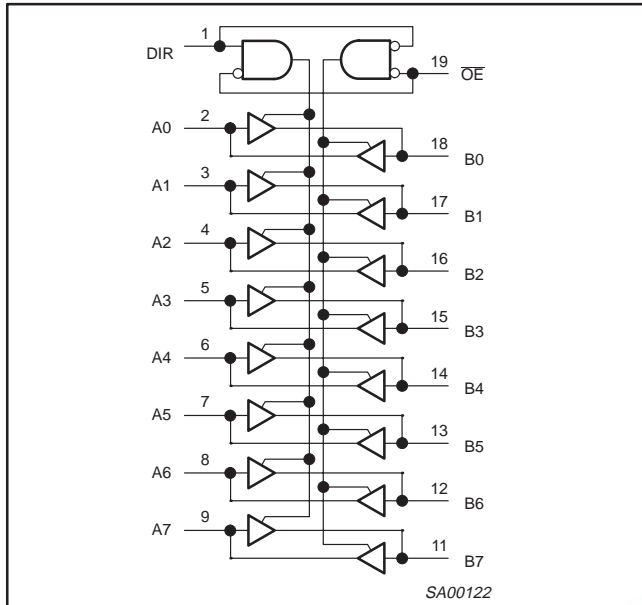

FUNCTION TABLE

| INPUTS | | INPUTS/OUTPUTS | |
|-----------------|-----|----------------|---------|
| \overline{OE} | DIR | An | Bn |
| L | L | An = Bn | Inputs |
| L | H | Inputs | Bn = An |
| H | X | Z | Z |

H = High voltage level
 L = Low voltage level
 X = Don't care
 Z = High impedance "off" state

SCHEMATIC OF EACH OUTPUT

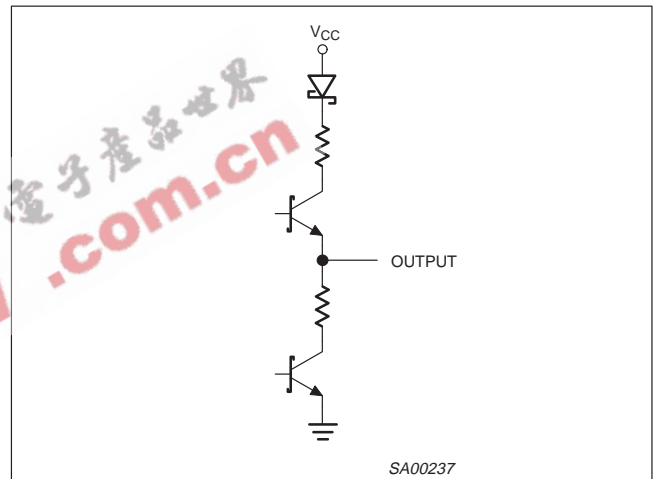

LOGIC SYMBOL IEEE/IEC

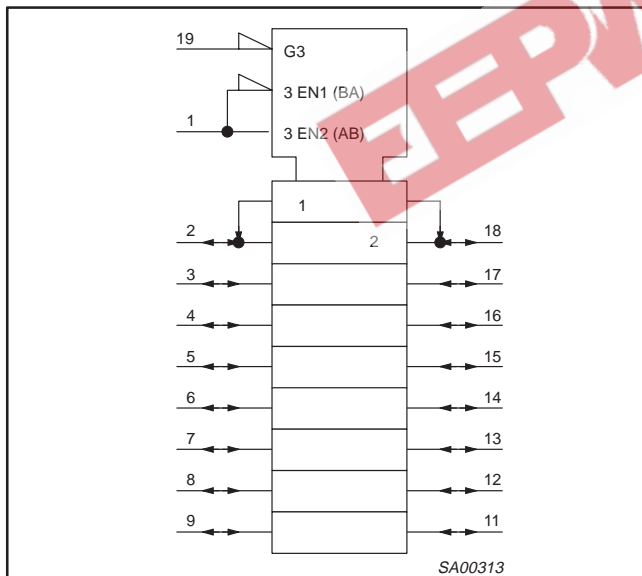

Octal transceiver with direction pin and 30Ω series termination resistors (3-State)

74ABT2245

ABSOLUTE MAXIMUM RATINGS^{1, 2}

| SYMBOL | PARAMETER | CONDITIONS | RATING | UNIT |
|-----------|--------------------------------|-----------------------------|--------------|------|
| V_{CC} | DC supply voltage | | -0.5 to +7.0 | V |
| I_{IK} | DC input diode current | $V_I < 0$ | -18 | mA |
| V_I | DC input voltage ³ | | -1.2 to +7.0 | V |
| I_{OK} | DC output diode current | $V_O < 0$ | -50 | mA |
| V_{OUT} | DC output voltage ³ | output in Off or High state | -0.5 to +5.5 | V |
| I_{OUT} | DC output current | output in Low state | 128 | mA |
| T_{stg} | Storage temperature range | | -65 to 150 | °C |

NOTES:

- Stresses beyond those listed may cause permanent damage to the device. These are stress ratings only and functional operation of the device at these or any other conditions beyond those indicated under "recommended operating conditions" is not implied. Exposure to absolute-maximum-rated conditions for extended periods may affect device reliability.
- The performance capability of a high-performance integrated circuit in conjunction with its thermal environment can create junction temperatures which are detrimental to reliability. The maximum junction temperature of this integrated circuit should not exceed 150°C.
- The input and output voltage ratings may be exceeded if the input and output current ratings are observed.

RECOMMENDED OPERATING CONDITIONS

| SYMBOL | PARAMETER | LIMITS | | UNIT |
|---------------------|--------------------------------------|--------|----------|------|
| | | Min | Max | |
| V_{CC} | DC supply voltage | 4.5 | 5.5 | V |
| V_I | Input voltage | 0 | V_{CC} | V |
| V_{IH} | High-level input voltage | 2.0 | | V |
| V_{IL} | Low-level Input voltage | | 0.8 | V |
| I_{OH} | High-level output current | | -32 | mA |
| I_{OL} | Low-level output current | | 12 | mA |
| $\Delta t/\Delta v$ | Input transition rise or fall rate | 0 | 5 | ns/V |
| T_{amb} | Operating free-air temperature range | -40 | +85 | °C |

Octal transceiver with direction pin and 30Ω series termination resistors (3-State)

74ABT2245

DC ELECTRICAL CHARACTERISTICS

| SYMBOL | PARAMETER | | TEST CONDITIONS | LIMITS | | | | | UNIT |
|------------------------------------|--|--------------|---|--------------------------|-------|------|--------------------------------------|------|------|
| | | | | T _{amb} = +25°C | | | T _{amb} = -40°C to +85°C | | |
| | | | | Min | Typ | Max | Min | Max | |
| V _{IK} | Input clamp voltage | | V _{CC} = 4.5V; I _{IK} = -18mA | | -0.9 | -1.2 | | -1.2 | V |
| V _{OH} | High-level output voltage | | V _{CC} = 4.5V; I _{OH} = -3mA; V _I = V _{IL} or V _{IH} | 2.5 | 2.9 | | 2.5 | | V |
| | | | V _{CC} = 5.0V; I _{OH} = -3mA; V _I = V _{IL} or V _{IH} | 3.0 | 3.4 | | 3.0 | | V |
| | | | V _{CC} = 4.5V; I _{OH} = -32mA; V _I = V _{IL} or V _{IH} | 2.0 | 2.4 | | 2.0 | | V |
| V _{OL} | Low-level output voltage | | V _{CC} = 4.5V; I _{OL} = 5mA; V _I = V _{IL} or V _{IH} | | 0.32 | 0.55 | | 0.55 | V |
| | | | V _{CC} = 4.5V; I _{OL} = 12mA; V _I = V _{IL} or V _{IH} | | 0.5 | 0.8 | | 0.8 | V |
| I _I | Input leakage current | Control pins | V _{CC} = 5.5V; V _I = GND or 5.5V | | ±0.01 | ±1.0 | | ±1.0 | μA |
| | | Data pins | V _{CC} = 5.5V; V _I = GND or 5.5V | | ±5 | ±100 | | ±100 | μA |
| I _{OFF} | Power-off leakage current | | V _{CC} = 0.0V; V _I or V _O ≤ 4.5V | | ±5.0 | ±100 | | ±100 | μA |
| I _{PU} /I _{PD} | Power-up/down 3-State output current ³ | | V _{CC} = 2.1V; V _O = 0.5V; V _I = GND or V _{CC} ; V _{OE} = Don't care | | ±5.0 | ±50 | | ±50 | μA |
| I _{IH} + I _{OZH} | 3-State output High current | | V _{CC} = 5.5V; V _O = 2.7V; V _I = V _{IL} or V _{IH} | | 5.0 | 50 | | 50 | μA |
| I _{IL} + I _{OZL} | 3-State output Low current | | V _{CC} = 5.5V; V _O = 0.5V; V _I = V _{IL} or V _{IH} | | -5.0 | -50 | | -50 | μA |
| I _{CEX} | Output high leakage current | | V _{CC} = 5.5V; V _O = 5.5V; V _I = GND or V _{CC} | | 5.0 | 50 | | 50 | μA |
| I _O | Output current ¹ | | V _{CC} = 5.5V; V _O = 2.5V | -40 | -100 | -180 | -40 | -180 | mA |
| I _{CCH} | Quiescent supply current | | V _{CC} = 5.5V; Outputs High, V _I = GND or V _{CC} | | 50 | 250 | | 250 | μA |
| I _{CCL} | | | V _{CC} = 5.5V; Outputs Low, V _I = GND or V _{CC} | | 24 | 30 | | 30 | mA |
| I _{CCZ} | | | V _{CC} = 5.5V; Outputs 3-State; V _I = GND or V _{CC} | | 50 | 250 | | 250 | μA |
| ΔI _{CC} | Additional supply current per input pin ² | | Outputs enabled, one input at 3.4V, other inputs at V _{CC} or GND; V _{CC} = 5.5V | | 0.5 | 1.5 | | 1.5 | mA |
| | | | Outputs 3-State, one data input at 3.4V, other inputs at V _{CC} or GND; V _{CC} = 5.5V | | 50 | 250 | | 250 | μA |
| | | | Outputs 3-State, one enable input at 3.4V, other inputs at V _{CC} or GND; V _{CC} = 5.5V | | 0.5 | 1.5 | | 1.5 | mA |

NOTES:

- Not more than one output should be tested at a time, and the duration of the test should not exceed one second.
- This is the increase in supply current for each input at 3.4V.
- This parameter is valid for any V_{CC} between 0V and 2.1V with a transition time of up to 10msec. From V_{CC} = 2.1V to V_{CC} = 5V ± 10%, a transition time of up to 100μsec is permitted.

Octal transceiver with direction pin and 30Ω series termination resistors (3-State)

74ABT2245

AC CHARACTERISTICS

GND = 0V; $t_R = t_F = 2.5\text{ns}$; $C_L = 50\text{pF}$, $R_L = 500\Omega$

| SYMBOL | PARAMETER | WAVEFORM | LIMITS | | | | | UNIT |
|--------------------------------------|--|----------|--|-----|-----|--|-----|------|
| | | | $T_{\text{amb}} = +25^\circ\text{C}$ $V_{\text{CC}} = +5.0\text{V}$ | | | $T_{\text{amb}} = -40^\circ\text{C to } +85^\circ\text{C}$ $V_{\text{CC}} = +5.0\text{V} \pm 0.5\text{V}$ | | |
| | | | Min | Typ | Max | Min | Max | |
| t_{PLH} t_{PHL} | Propagation delay An to Bn or Bn to An | 1 | 1.0 | 2.8 | 4.2 | 1.0 | 4.7 | ns |
| t_{PZH} t_{PZL} | Output enable time to High and Low level | 2 | 1.3 | 3.5 | 4.6 | 1.3 | 5.5 | ns |
| t_{PHZ} t_{PLZ} | Output disable time from High and Low Level | 2 | 1.5 | 4.0 | 5.4 | 1.5 | 6.3 | ns |

AC WAVEFORMS

$V_M = 1.5\text{V}$, $V_{\text{IN}} = \text{GND to } 3.0\text{V}$

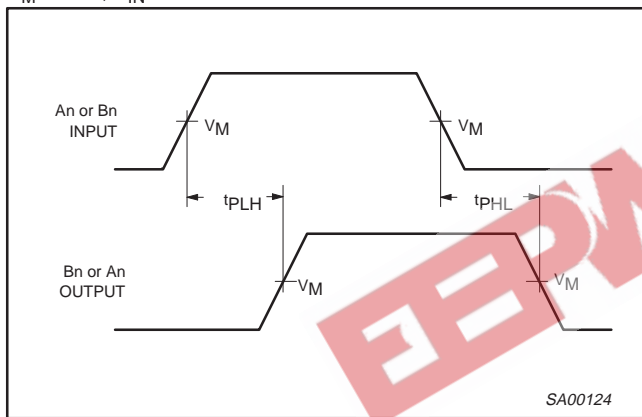

Waveform 1. Waveforms Showing the Input to Output Propagation Delays

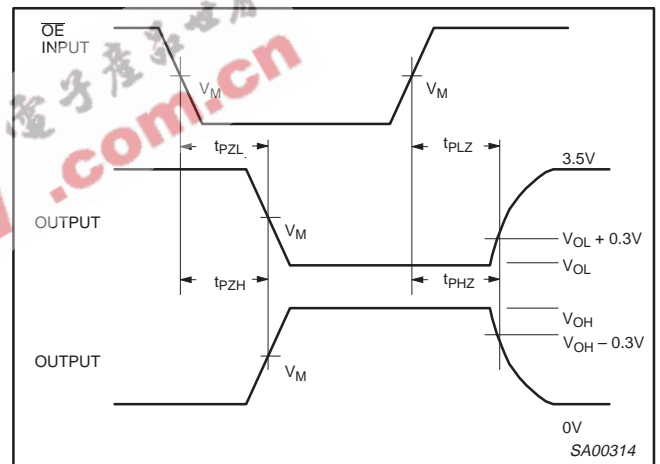

Waveform 2. Waveforms Showing the 3-State Output Enable and Disable Times

TEST CIRCUIT AND WAVEFORMS

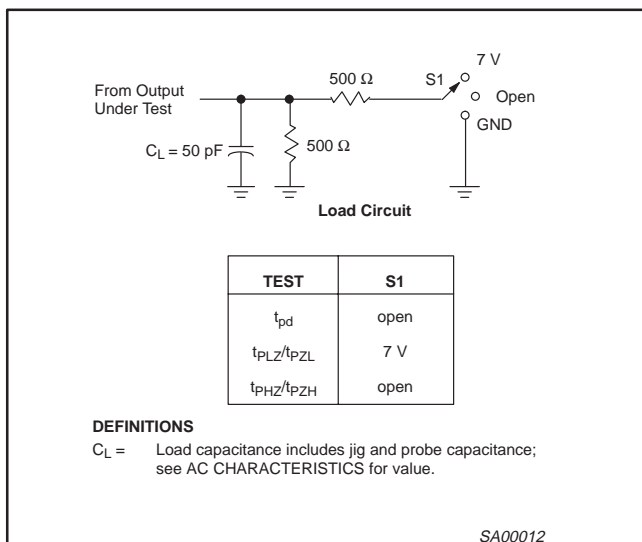

Octal transceiver with direction pin
and 30Ω series termination resistors (3-State)

74ABT2245

DIP20: plastic dual in-line package; 20 leads (300 mil)

SOT146-1

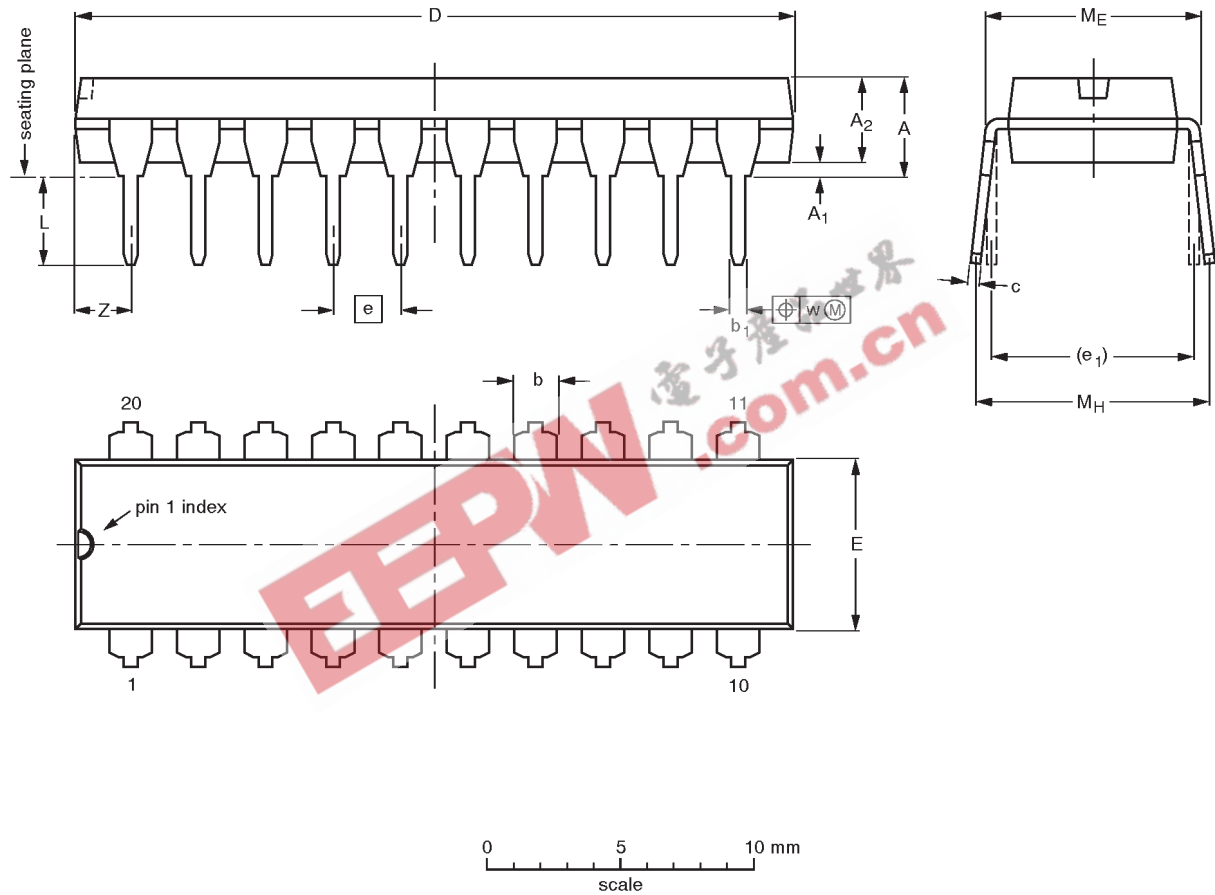

DIMENSIONS (inch dimensions are derived from the original mm dimensions)

| UNIT | A max. | A ₁ min. | A ₂ max. | b | b ₁ | c | D ⁽¹⁾ | E ⁽¹⁾ | e | e ₁ | L | M _E | M _H | w | Z ⁽¹⁾ max. |
|--------|--------|---------------------|---------------------|----------------|----------------|----------------|------------------|------------------|------|----------------|--------------|----------------|----------------|-------|-----------------------|
| mm | 4.2 | 0.51 | 3.2 | 1.73 1.30 | 0.53 0.38 | 0.36 0.23 | 26.92 26.54 | 6.40 6.22 | 2.54 | 7.62 | 3.60 3.05 | 8.25 7.80 | 10.0 8.3 | 0.254 | 2.0 |
| inches | 0.17 | 0.020 | 0.13 | 0.068 0.051 | 0.021 0.015 | 0.014 0.009 | 1.060 1.045 | 0.25 0.24 | 0.10 | 0.30 | 0.14 0.12 | 0.32 0.31 | 0.39 0.33 | 0.01 | 0.078 |

Note

1. Plastic or metal protrusions of 0.25 mm maximum per side are not included.

| OUTLINE VERSION | REFERENCES | | | | EUROPEAN PROJECTION | ISSUE DATE |
|-----------------|------------|-------|-------|--|---------------------|----------------------|
| | IEC | JEDEC | EIAJ | | | |
| SOT146-1 | | | SC603 | | | 92-11-17 95-05-24 |

Octal transceiver with direction pin
and 30Ω series termination resistors (3-State)

74ABT2245

SO20: plastic small outline package; 20 leads; body width 7.5 mm

SOT163-1

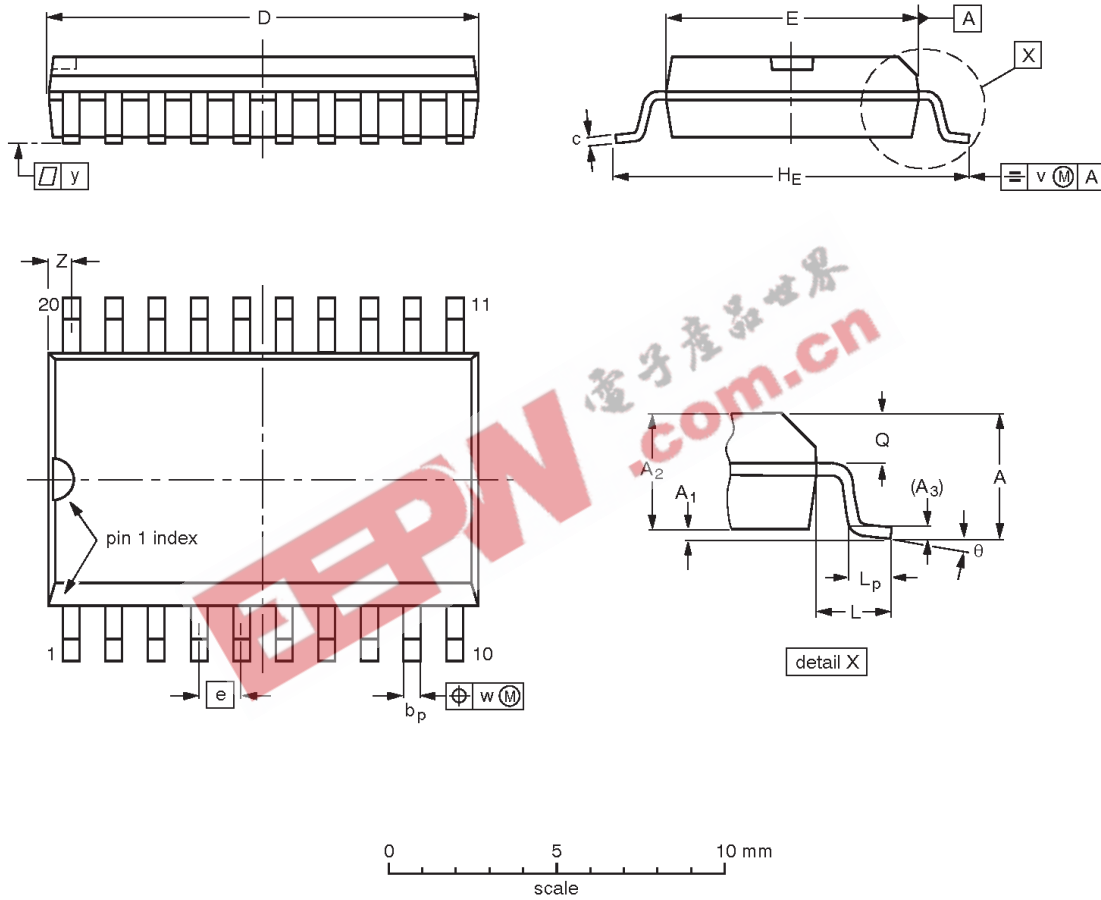

DIMENSIONS (inch dimensions are derived from the original mm dimensions)

| UNIT | A max. | A ₁ | A ₂ | A ₃ | b _p | c | D ⁽¹⁾ | E ⁽¹⁾ | e | H _E | L | L _p | Q | v | w | y | z ⁽¹⁾ | θ |
|--------|--------|----------------|----------------|----------------|----------------|----------------|------------------|------------------|-------|----------------|-------|----------------|----------------|------|------|-------|------------------|----------|
| mm | 2.65 | 0.30 0.10 | 2.45 2.25 | 0.25 | 0.49 0.36 | 0.32 0.23 | 13.0 12.6 | 7.6 7.4 | 1.27 | 10.65 10.00 | 1.4 | 1.1 0.4 | 1.1 1.0 | 0.25 | 0.25 | 0.1 | 0.9 0.4 | 8° 0° |
| inches | 0.10 | 0.012 0.004 | 0.096 0.089 | 0.01 | 0.019 0.014 | 0.013 0.009 | 0.51 0.49 | 0.30 0.29 | 0.050 | 0.42 0.39 | 0.055 | 0.043 0.016 | 0.043 0.039 | 0.01 | 0.01 | 0.004 | 0.035 0.016 | |

Note

1. Plastic or metal protrusions of 0.15 mm maximum per side are not included.

| OUTLINE VERSION | REFERENCES | | | | EUROPEAN PROJECTION | ISSUE DATE |
|-----------------|------------|----------|------|--|---------------------|----------------------|
| | IEC | JEDEC | EIAJ | | | |
| SOT163-1 | 075E04 | MS-013AC | | | | 92-11-17 95-01-24 |

Octal transceiver with direction pin
and 30Ω series termination resistors (3-State)

74ABT2245

SSOP20: plastic shrink small outline package; 20 leads; body width 5.3 mm

SOT339-1

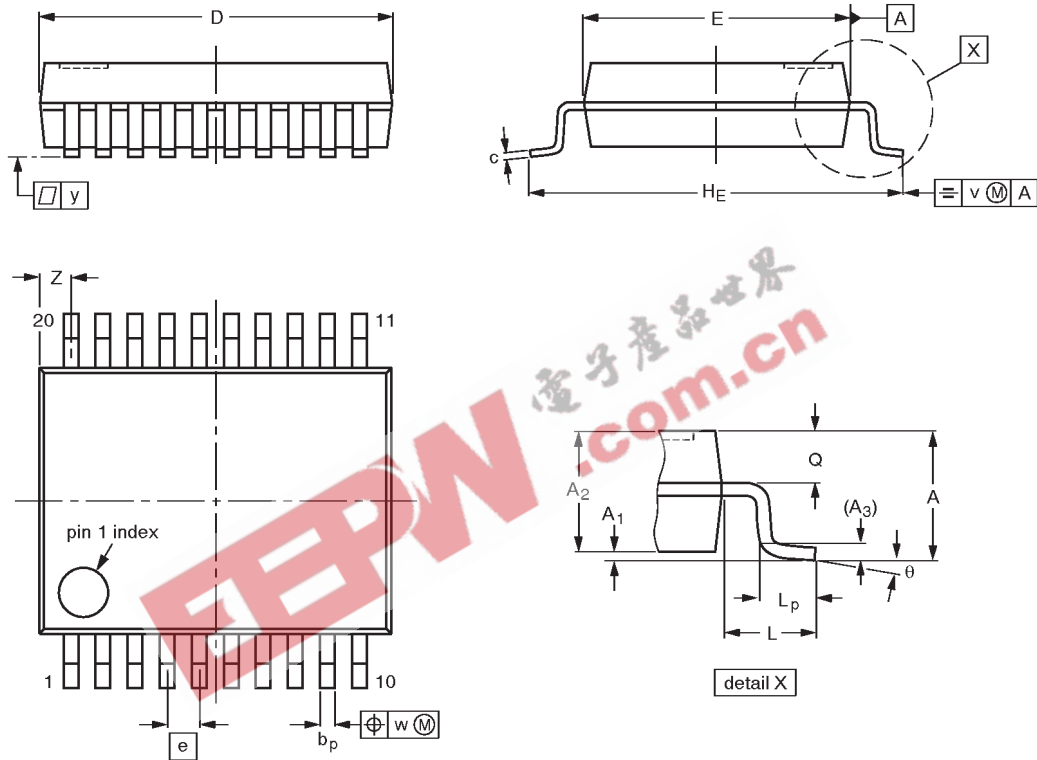

DIMENSIONS (mm are the original dimensions)

| UNIT | A max. | A ₁ | A ₂ | A ₃ | b _p | c | D ⁽¹⁾ | E ⁽¹⁾ | e | H _E | L | L _p | Q | v | w | y | z ⁽¹⁾ | θ |
|------|--------|----------------|----------------|----------------|----------------|--------------|------------------|------------------|------|----------------|------|----------------|------------|-----|------|-----|------------------|----------|
| mm | 2.0 | 0.21 0.05 | 1.80 1.65 | 0.25 | 0.38 0.25 | 0.20 0.09 | 7.4 7.0 | 5.4 5.2 | 0.65 | 7.9 7.6 | 1.25 | 1.03 0.63 | 0.9 0.7 | 0.2 | 0.13 | 0.1 | 0.9 0.5 | 8° 0° |

Note

1. Plastic or metal protrusions of 0.20 mm maximum per side are not included.

| OUTLINE VERSION | REFERENCES | | | | EUROPEAN PROJECTION | ISSUE DATE |
|-----------------|------------|----------|------|--|---------------------|----------------------|
| | IEC | JEDEC | EIAJ | | | |
| SOT339-1 | | MO-150AE | | | | 93-09-08 95-02-04 |

Octal transceiver with direction pin
and 30Ω series termination resistors (3-State)

74ABT2245

TSSOP20: plastic thin shrink small outline package; 20 leads; body width 4.4 mm

SOT360-1

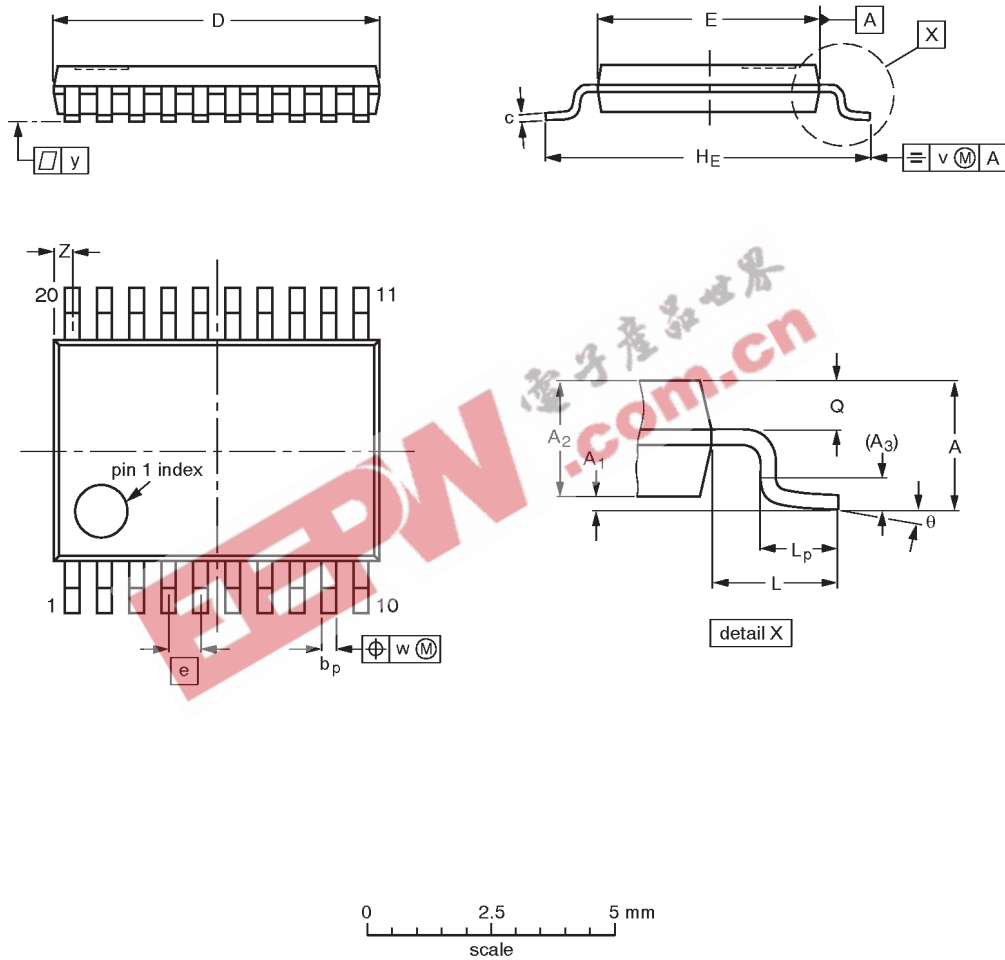

DIMENSIONS (mm are the original dimensions)

| UNIT | A max. | A ₁ | A ₂ | A ₃ | b _p | c | D ⁽¹⁾ | E ⁽²⁾ | e | H _E | L | L _p | Q | v | w | y | Z ⁽¹⁾ | θ |
|------|--------|----------------|----------------|----------------|----------------|------------|------------------|------------------|------|----------------|-----|----------------|------------|-----|------|-----|------------------|----------|
| mm | 1.10 | 0.15 0.05 | 0.95 0.80 | 0.25 | 0.30 0.19 | 0.2 0.1 | 6.6 6.4 | 4.5 4.3 | 0.65 | 6.6 6.2 | 1.0 | 0.75 0.50 | 0.4 0.3 | 0.2 | 0.13 | 0.1 | 0.5 0.2 | 8° 0° |

Notes

1. Plastic or metal protrusions of 0.15 mm maximum per side are not included.
2. Plastic interlead protrusions of 0.25 mm maximum per side are not included.

| OUTLINE VERSION | REFERENCES | | | | EUROPEAN PROJECTION | ISSUE DATE |
|-----------------|------------|----------|------|--|---------------------|----------------------|
| | IEC | JEDEC | EIAJ | | | |
| SOT360-1 | | MO-153AC | | | | 93-06-16 95-02-04 |

Octal transceiver with direction pin
and 30Ω series termination resistors (3-State)

74ABT2245

NOTES



Octal transceiver with direction pin and 30Ω series termination resistors (3-State)

74ABT2245

Data sheet status

| Data sheet status | Product status | Definition [1] |
|---------------------------|----------------|--|
| Objective specification | Development | This data sheet contains the design target or goal specifications for product development. Specification may change in any manner without notice. |
| Preliminary specification | Qualification | This data sheet contains preliminary data, and supplementary data will be published at a later date. Philips Semiconductors reserves the right to make changes at any time without notice in order to improve design and supply the best possible product. |
| Product specification | Production | This data sheet contains final specifications. Philips Semiconductors reserves the right to make changes at any time without notice in order to improve design and supply the best possible product. |

[1] Please consult the most recently issued datasheet before initiating or completing a design.

Definitions

Short-form specification — The data in a short-form specification is extracted from a full data sheet with the same type number and title. For detailed information see the relevant data sheet or data handbook.

Limiting values definition — Limiting values given are in accordance with the Absolute Maximum Rating System (IEC 134). Stress above one or more of the limiting values may cause permanent damage to the device. These are stress ratings only and operation of the device at these or at any other conditions above those given in the Characteristics sections of the specification is not implied. Exposure to limiting values for extended periods may affect device reliability.

Application information — Applications that are described herein for any of these products are for illustrative purposes only. Philips Semiconductors make no representation or warranty that such applications will be suitable for the specified use without further testing or modification.

Disclaimers

Life support — These products are not designed for use in life support appliances, devices or systems where malfunction of these products can reasonably be expected to result in personal injury. Philips Semiconductors customers using or selling these products for use in such applications do so at their own risk and agree to fully indemnify Philips Semiconductors for any damages resulting from such application.

Right to make changes — Philips Semiconductors reserves the right to make changes, without notice, in the products, including circuits, standard cells, and/or software, described or contained herein in order to improve design and/or performance. Philips Semiconductors assumes no responsibility or liability for the use of any of these products, conveys no license or title under any patent, copyright, or mask work right to these products, and makes no representations or warranties that these products are free from patent, copyright, or mask work right infringement, unless otherwise specified.

Philips Semiconductors
811 East Arques Avenue
P.O. Box 3409
Sunnyvale, California 94088-3409
Telephone 800-234-7381

© Copyright Philips Electronics North America Corporation 1998
All rights reserved. Printed in U.S.A.

print code

Date of release: 05-96

Document order number:

9397-750-03468

Let's make things better.