

DATA SHEET

EEPW 电子產品世界
.com.cn

74LVC125A

Quad buffer/line driver with 5-volt tolerant inputs/outputs (3-State)

Product specification
Supersedes data of 1997 Aug 01
IC24 Data Handbook

1998 Apr 28

Quad buffer/line driver with 5-volt tolerant inputs/outputs (3-state)

74LVC125A

FEATURES

- 5-volt tolerant inputs/outputs, for interfacing with 5-volt logic
- Supply voltage range of 1.2V to 3.6V
- Complies with JEDEC standard no. 8-1A
- CMOS low power consumption
- Direct interface with TTL levels
- High impedance when $V_{CC} = 0V$

DESCRIPTION

The 74LVC125A is a high performance, low-power, low-voltage Si-gate CMOS device and superior to most advanced CMOS compatible TTL families.

Inputs can be driven from either 3.3V or 5.0V devices. In 3-state operation, outputs can handle 5V.

The 74LVC125A consists of four non-inverting buffers/line drivers with 3-state outputs. The 3-state outputs (nY) are controlled by the output enable input (n \overline{OE}). A HIGH at n \overline{OE} causes the outputs to assume a high impedance OFF-state.

QUICK REFERENCE DATA

GND = 0 V; $T_{amb} = 25^{\circ}C$; $t_r = t_f \leq 2.5$ ns

SYMBOL	PARAMETER	CONDITIONS	TYPICAL	UNIT
t_{PHL}/t_{PLH}	Propagation delay nA to nY	$C_L = 50$ pF; $V_{CC} = 3.3$ V	3.0	ns
C_I	Input capacitance		5.0	pF
C_{PD}	Power dissipation capacitance per buffer	$V_{CC} = 3.3$ V Notes 1 and 2	25	pF

NOTES:

1. C_{PD} is used to determine the dynamic power dissipation (P_D in μW)
 $P_D = C_{PD} \times V_{CC}^2 \times f_i + \sum (C_L \times V_{CC}^2 \times f_o)$ where:
 f_i = input frequency in MHz; C_L = output load capacity in pF;
 f_o = output frequency in MHz; V_{CC} = supply voltage in V;
 $\sum (C_L \times V_{CC}^2 \times f_o)$ = sum of the outputs.
2. The condition is $V_I = GND$ to V_{CC}

ORDERING INFORMATION

PACKAGES	TEMPERATURE RANGE	OUTSIDE NORTH AMERICA	NORTH AMERICA	PKG. DWG. #
14-Pin Plastic SO	$-40^{\circ}C$ to $+125^{\circ}C$	74LVC125A D	74LVC125A D	SOT108-1
14-Pin Plastic SSOP Type II	$-40^{\circ}C$ to $+125^{\circ}C$	74LVC125A DB	74LVC125A DB	SOT337-1
14-Pin Plastic TSSOP Type I	$-40^{\circ}C$ to $+125^{\circ}C$	74LVC125A PW	7LVC125APW DH	SOT402-1

Quad buffer/line driver with 5-volt tolerant inputs/outputs (3-state)

74LVC125A

PIN CONFIGURATION

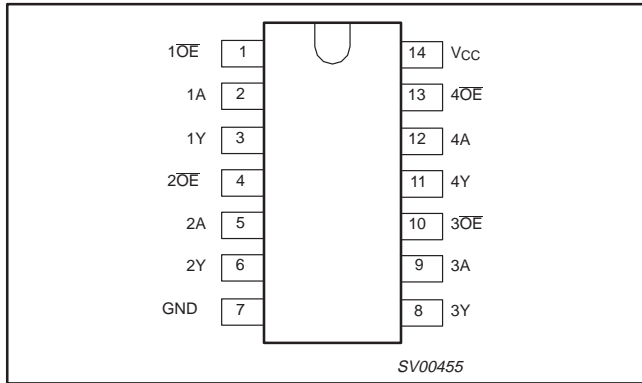

FUNCTION TABLE

INPUTS		OUTPUT
nOE	nA	nY
L	L	L
L	H	H
H	X	Z

NOTES:

- H = HIGH voltage level
- L = LOW voltage level
- X = don't care
- Z = high impedance OFF-state

PIN DESCRIPTION

PIN NUMBER	SYMBOL	NAME AND FUNCTION
1, 4, 10, 13	1OE – 4OE	Data enable inputs (active LOW)
2, 5, 9, 12	1A – 4A	Data inputs
3, 6, 8, 11	1Y – 4Y	Data Outputs
7	GND	Ground (0 V)
14	V _{CC}	Positive supply voltage

LOGIC SYMBOL (IEEE/IEC)

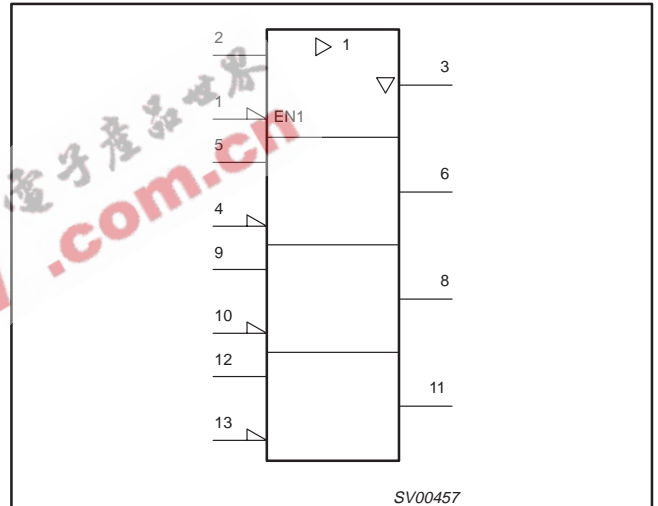

LOGIC SYMBOL

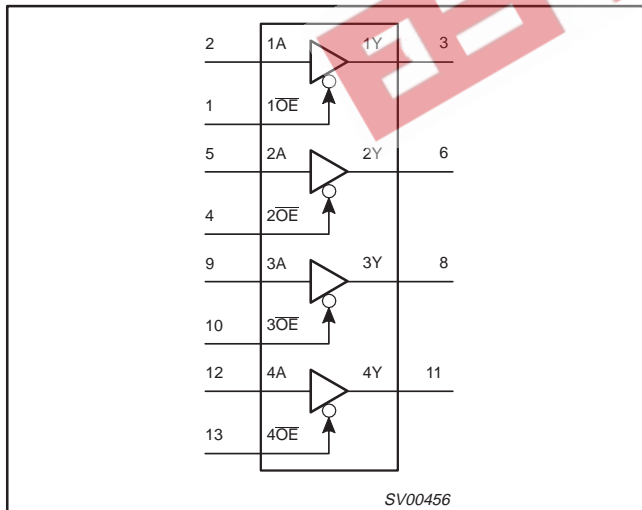

Quad buffer/line driver with 5-volt tolerant inputs/outputs (3-state)

74LVC125A

RECOMMENDED OPERATING CONDITIONS

SYMBOL	PARAMETER	CONDITIONS	LIMITS		UNIT
			MIN	MAX	
V_{CC}	DC supply voltage (for max. speed performance)		2.7	3.6	V
	DC supply voltage (for low-voltage applications)		1.2	3.6	
V_I	DC input voltage range		0	5.5	V
V_O	DC output voltage range; output HIGH or LOW state		0	V_{CC}	V
	DC output voltage range; output 3-State		0	5.5	
T_{amb}	Operating ambient temperature range in free-air		-40	+85	°C
t_r, t_f	Input rise and fall times	$V_{CC} = 1.2$ to $2.7V$ $V_{CC} = 2.7$ to $3.6V$	0 0	20 10	ns/V

ABSOLUTE MAXIMUM RATINGS¹

In accordance with the Absolute Maximum Rating System (IEC 134)
Voltages are referenced to GND (ground = 0V)

SYMBOL	PARAMETER	CONDITIONS	RATING	UNIT
V_{CC}	DC supply voltage		-0.5 to +6.5	V
I_{IK}	DC input diode current	$V_I < 0$	-50	mA
V_I	DC input voltage	Note 2	-0.5 to +6.5	V
I_{OK}	DC output diode current	$V_O > V_{CC}$ or $V_O < 0$	± 50	mA
V_O	DC output voltage; output HIGH or LOW state	Note 2	-0.5 to $V_{CC} + 0.5$	V
	DC output voltage; output 3-State	Note 2	-0.5 to 6.5	
I_{OUT}	DC output source or sink current	$V_O = 0$ to V_{CC}	± 50	mA
I_{GND}, I_{CC}	DC V_{CC} or GND current		± 100	mA
T_{stg}	Storage temperature range		-65 to +150	°C
P_{TOT}	Power dissipation per package			
	- plastic mini-pack (SO) - plastic shrink mini-pack (SSOP and TSSOP)	above +70°C derate linearly with 8 mW/K above +60°C derate linearly with 5.5 mW/K	500 500	mW

NOTES:

- Stresses beyond those listed may cause permanent damage to the device. These are stress ratings only and functional operation of the device at these or any other conditions beyond those indicated under "recommended operating conditions" is not implied. Exposure to absolute-maximum-rated conditions for extended periods may affect device reliability.
- The input and output voltage ratings may be exceeded if the input and output current ratings are observed.

Quad buffer/line driver with 5-volt tolerant inputs/outputs (3-state)

74LVC125A

DC ELECTRICAL CHARACTERISTICS

Over recommended operating conditions voltages are referenced to GND (ground = 0V)

SYMBOL	PARAMETER	TEST CONDITIONS	LIMITS			UNIT
			Temp = -40°C to +85°C			
			MIN	TYP ¹	MAX	
V _{IH}	HIGH level Input voltage	V _{CC} = 1.2V	V _{CC}			V
		V _{CC} = 2.7 to 3.6V	2.0			
V _{IL}	LOW level Input voltage	V _{CC} = 1.2V			GND	V
		V _{CC} = 2.7 to 3.6V			0.8	
V _{OH}	HIGH level output voltage	V _{CC} = 2.7V; V _I = V _{IH} or V _{IL} ; I _O = -12mA	V _{CC} - 0.5			V
		V _{CC} = 3.0V; V _I = V _{IH} or V _{IL} ; I _O = -100μA	V _{CC} - 0.2	V _{CC}		
		V _{CC} = 3.0V; V _I = V _{IH} or V _{IL} ; I _O = -18mA	V _{CC} - 0.6			
		V _{CC} = 3.0V; V _I = V _{IH} or V _{IL} ; I _O = -24mA	V _{CC} - 0.8			
V _{OL}	LOW level output voltage	V _{CC} = 2.7V; V _I = V _{IH} or V _{IL} ; I _O = 12mA			0.40	V
		V _{CC} = 3.0V; V _I = V _{IH} or V _{IL} ; I _O = 100μA		GND	0.20	
		V _{CC} = 3.0V; V _I = V _{IH} or V _{IL} ; I _O = 24mA			0.55	
I _I	Input leakage current	V _{CC} = 3.6V; V _I = 5.5V or GND		±0.1	±5	μA
I _{OZ}	3-State output OFF-state current ²	V _{CC} = 3.6V; V _I = V _{IH} or V _{IL} ; V _O = 5.5V or GND		0.1	±5	μA
I _{off}	Power off leakage supply	V _{CC} = 0.0V; V _I or V _O = 5.5V		0.1	±10	μA
I _{CC}	Quiescent supply current	V _{CC} = 3.6V; V _I = V _{CC} or GND; I _O = 0		0.1	10	μA
ΔI _{CC}	Additional quiescent supply current per input pin	V _{CC} = 2.7V to 3.6V; V _I = V _{CC} - 0.6V; I _O = 0		5	500	μA

NOTE:

- All typical values are at V_{CC} = 3.3V and T_{amb} = 25°C.
- For I/O ports the parameter I_{OZ} includes the input leakage current.

AC CHARACTERISTICS

GND = 0 V; t_r = t_f = 2.5 ns; C_L = 50 pF; R_L = 500Ω

SYMBOL	PARAMETER	WAVEFORM	LIMITS						UNIT
			V _{CC} = 3.3V ±0.3V			V _{CC} = 2.7V		V _{CC} = 1.2V	
			MIN	TYP ¹	MAX	MIN	MAX	TYP	
t _{PHL} t _{PLH}	Propagation delay nA to nY	Figures 1, 3	1.5	3.0	4.8	1.5	5.5	12.0	ns
t _{PZH} t _{PZL}	3-State output enable time nOE to nY	Figures 2, 3	1.5	3.8	5.7	1.5	6.7	13.0	ns
t _{PHZ} t _{PLZ}	3-State output disable time nOE to nY	Figures 2, 3	1.5	3.7	5.2	1.5	6.2	8	ns

NOTE:

- These typical values are at V_{CC} = 3.3V and T_{amb} = 25°C.

Quad buffer/line driver with 5-volt tolerant inputs/outputs (3-state)

74LVC125A

AC WAVEFORMS

$V_M = 1.5\text{ V}$ at $V_{CC} \geq 2.7\text{ V}$;
 $V_M = 0.5 \cdot V_{CC}$ at $V_{CC} < 2.7\text{ V}$
 V_{OL} and V_{OH} are the typical output voltage drop that occur with the output load.
 $V_X = V_{OL} + 0.3\text{ V}$ at $V_{CC} \geq 2.7\text{ V}$
 $V_X = V_{OL} + 0.1\text{ V}$ at $V_{CC} < 2.7\text{ V}$
 $V_Y = V_{OH} - 0.3\text{ V}$ at $V_{CC} \geq 2.7\text{ V}$
 $V_Y = V_{OH} - 0.1\text{ V}$ at $V_{CC} < 2.7\text{ V}$

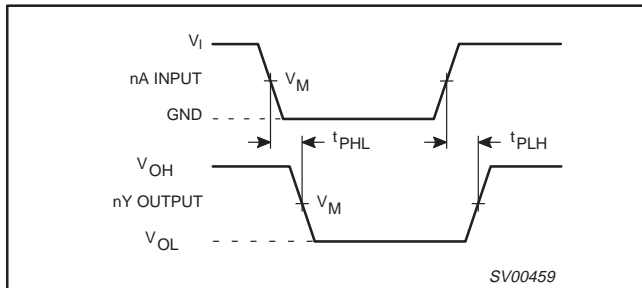

Figure 1. Input (nA) to output (nY) propagation delays.

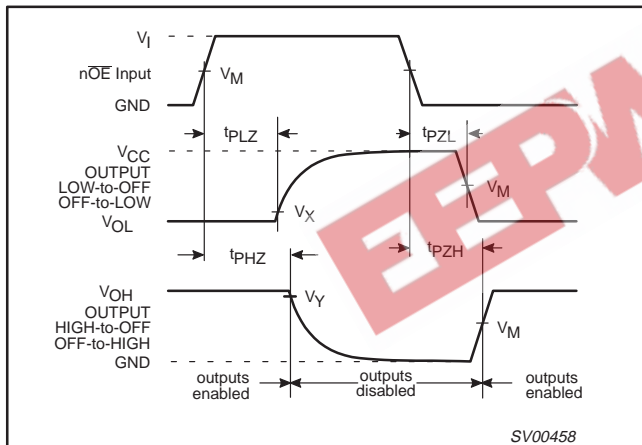

Figure 2. 3-state enable and disable times.

TEST CIRCUIT

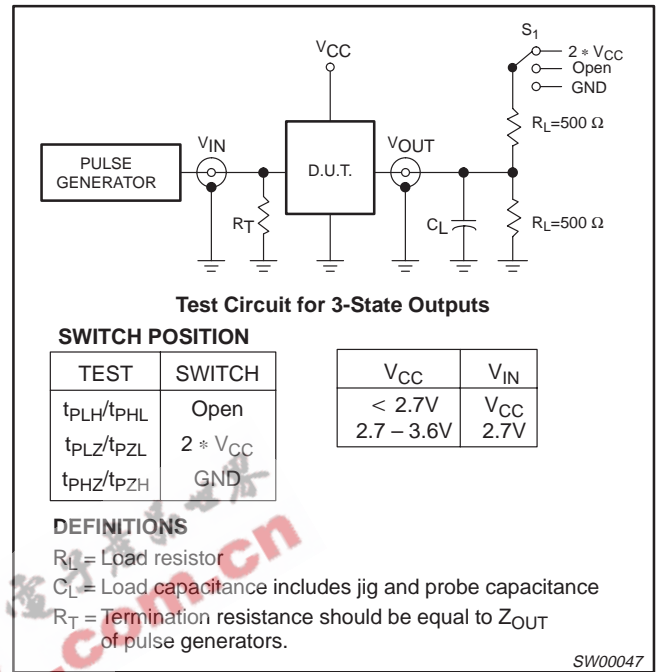

Figure 3. Load circuitry for switching times.

Quad buffer/line driver with 5-volt tolerant inputs/outputs (3-State)

74LVC125A

SO14: plastic small outline package; 14 leads; body width 3.9 mm

SOT108-1

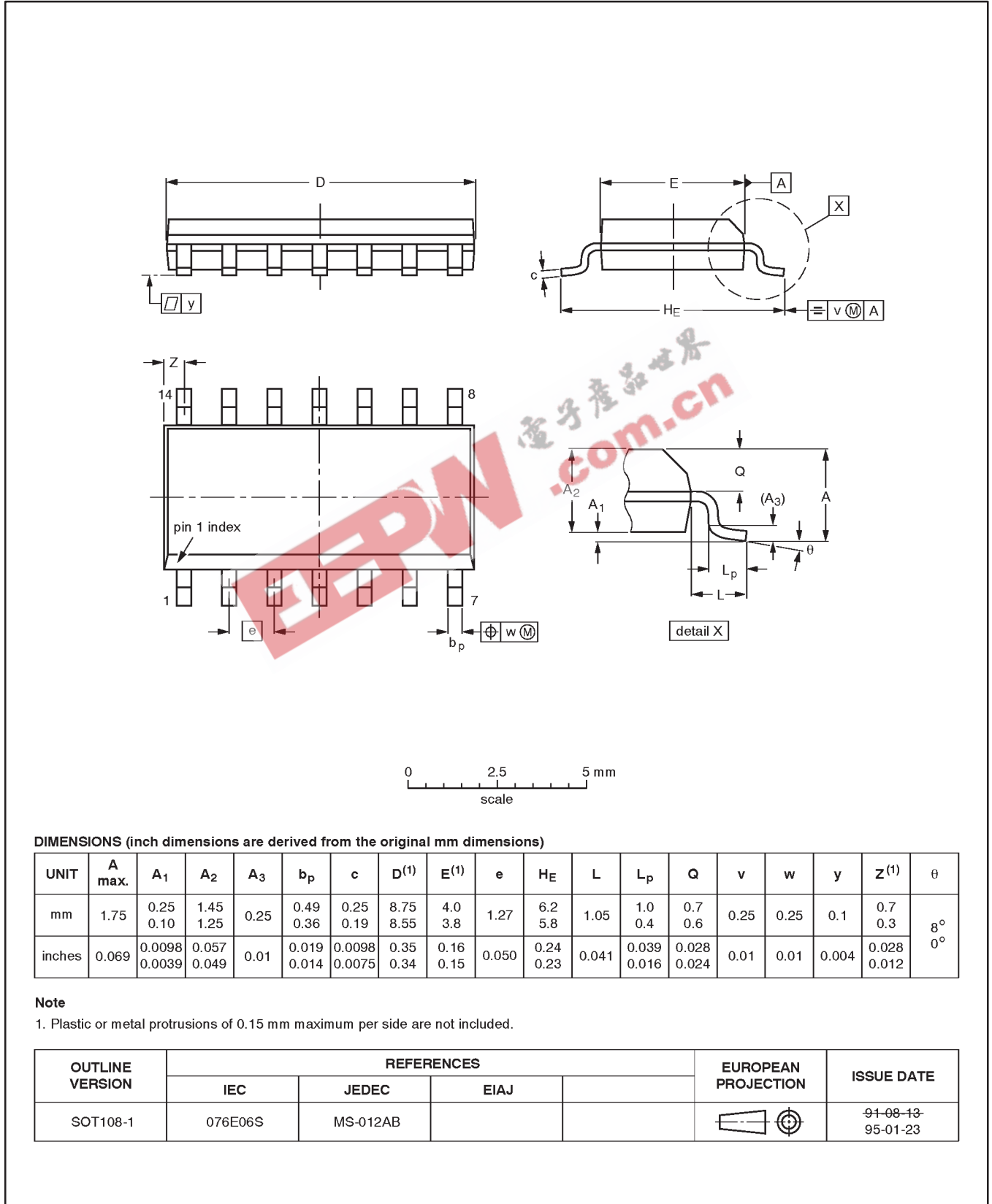

Quad buffer/line driver with 5-volt tolerant inputs/outputs (3-State)

74LVC125A

SSOP14: plastic shrink small outline package; 14 leads; body width 5.3 mm

SOT337-1

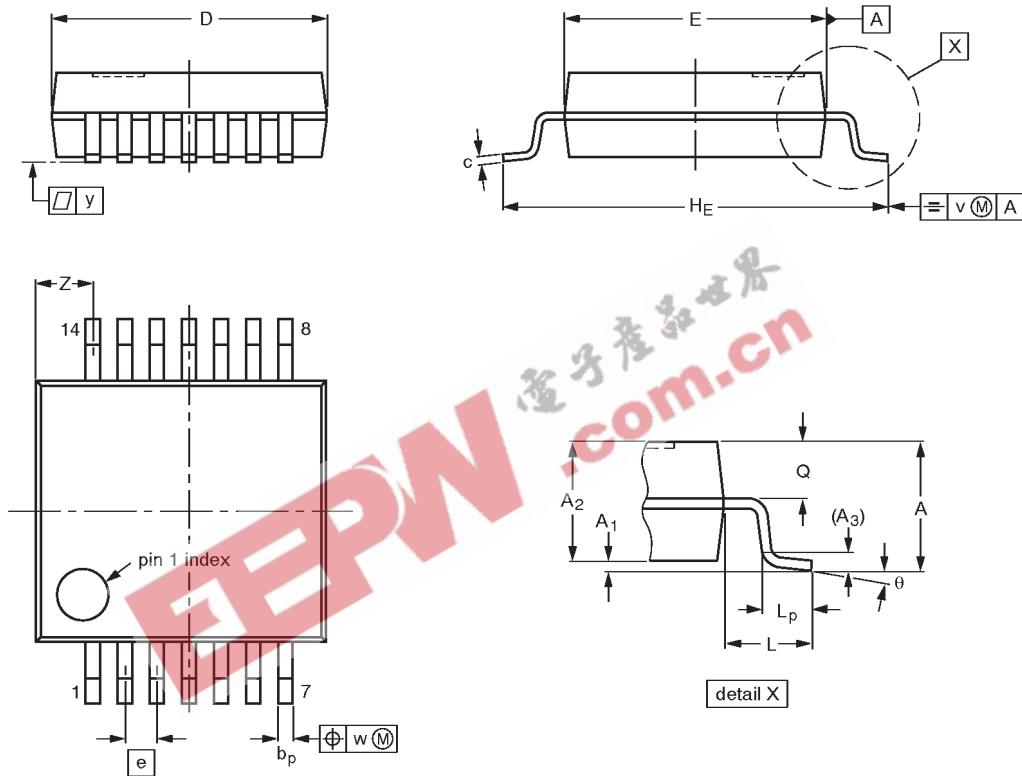

DIMENSIONS (mm are the original dimensions)

UNIT	A max.	A ₁	A ₂	A ₃	b _p	c	D ⁽¹⁾	E ⁽¹⁾	e	H _E	L	L _p	Q	v	w	y	Z ⁽¹⁾	θ
mm	2.0	0.21 0.05	1.80 1.65	0.25	0.38 0.25	0.20 0.09	6.4 6.0	5.4 5.2	0.65	7.9 7.6	1.25	1.03 0.63	0.9 0.7	0.2	0.13	0.1	1.4 0.9	8° 0°

Note

1. Plastic or metal protrusions of 0.25 mm maximum per side are not included.

OUTLINE VERSION	REFERENCES				EUROPEAN PROJECTION	ISSUE DATE
	IEC	JEDEC	EIAJ			
SOT337-1		MO-150AB				95-02-04 96-01-18

Quad buffer/line driver with 5-volt tolerant inputs/outputs (3-State)

74LVC125A

TSSOP14: plastic thin shrink small outline package; 14 leads; body width 4.4 mm

SOT402-1

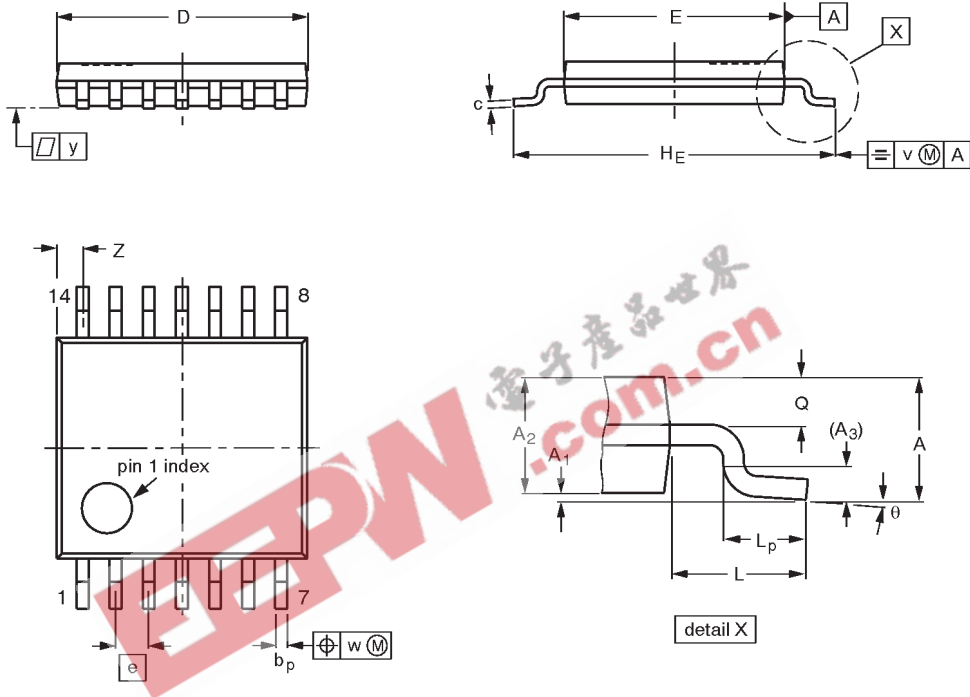

DIMENSIONS (mm are the original dimensions)

UNIT	A max.	A ₁	A ₂	A ₃	b _p	c	D ⁽¹⁾	E ⁽²⁾	e	H _E	L	L _p	Q	v	w	y	Z ⁽¹⁾	θ
mm	1.10	0.15 0.05	0.95 0.80	0.25	0.30 0.19	0.2 0.1	5.1 4.9	4.5 4.3	0.65	6.6 6.2	1.0	0.75 0.50	0.4 0.3	0.2	0.13	0.1	0.72 0.38	8° 0°

Notes

1. Plastic or metal protrusions of 0.15 mm maximum per side are not included.
2. Plastic interlead protrusions of 0.25 mm maximum per side are not included.

OUTLINE VERSION	REFERENCES				EUROPEAN PROJECTION	ISSUE DATE
	IEC	JEDEC	EIAJ			
SOT402-1		MO-153				-94-07-12- 95-04-04

Quad buffer/line driver with 5-volt tolerant inputs/outputs (3-State)

74LVC125A

Data sheet status

Data sheet status	Product status	Definition [1]
Objective specification	Development	This data sheet contains the design target or goal specifications for product development. Specification may change in any manner without notice.
Preliminary specification	Qualification	This data sheet contains preliminary data, and supplementary data will be published at a later date. Philips Semiconductors reserves the right to make changes at any time without notice in order to improve design and supply the best possible product.
Product specification	Production	This data sheet contains final specifications. Philips Semiconductors reserves the right to make changes at any time without notice in order to improve design and supply the best possible product.

[1] Please consult the most recently issued datasheet before initiating or completing a design.

Definitions

Short-form specification — The data in a short-form specification is extracted from a full data sheet with the same type number and title. For detailed information see the relevant data sheet or data handbook.

Limiting values definition — Limiting values given are in accordance with the Absolute Maximum Rating System (IEC 134). Stress above one or more of the limiting values may cause permanent damage to the device. These are stress ratings only and operation of the device at these or at any other conditions above those given in the Characteristics sections of the specification is not implied. Exposure to limiting values for extended periods may affect device reliability.

Application information — Applications that are described herein for any of these products are for illustrative purposes only. Philips Semiconductors make no representation or warranty that such applications will be suitable for the specified use without further testing or modification.

Disclaimers

Life support — These products are not designed for use in life support appliances, devices or systems where malfunction of these products can reasonably be expected to result in personal injury. Philips Semiconductors customers using or selling these products for use in such applications do so at their own risk and agree to fully indemnify Philips Semiconductors for any damages resulting from such application.

Right to make changes — Philips Semiconductors reserves the right to make changes, without notice, in the products, including circuits, standard cells, and/or software, described or contained herein in order to improve design and/or performance. Philips Semiconductors assumes no responsibility or liability for the use of any of these products, conveys no license or title under any patent, copyright, or mask work right to these products, and makes no representations or warranties that these products are free from patent, copyright, or mask work right infringement, unless otherwise specified.

Philips Semiconductors
811 East Arques Avenue
P.O. Box 3409
Sunnyvale, California 94088-3409
Telephone 800-234-7381

© Copyright Philips Electronics North America Corporation 1998
All rights reserved. Printed in U.S.A.

print code

Date of release: 05-96

Document order number:

9397-750-04491

Let's make things better.