

74F365 Hex Buffer/Driver with 3-STATE Outputs

General Description

The 74F365 is a hex buffer and line driver designed to be employed as a memory and address driver, clock driver and bus-oriented transmitter/receiver.

Features

- 3-STATE buffer outputs
- Outputs sink 64 mA
- Bus-oriented

Ordering Code:

Order Number	Package Number	Package Description
74F365SC	M16A	16-Lead Small Outline Integrated Circuit (SOIC), JEDEC MS-012, 0.150 Narrow
74F365PC	N16E	16-Lead Plastic Dual-In-Line Package (PDIP), JEDEC MS-001, 0.300 Wide

Devices also available in Tape and Reel. Specify by appending the suffix letter "X" to the ordering code.

Logic Symbol

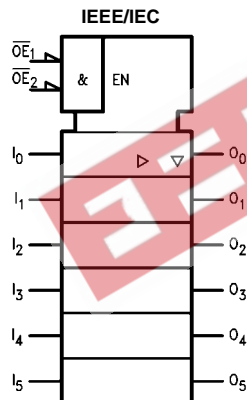

Connection Diagram

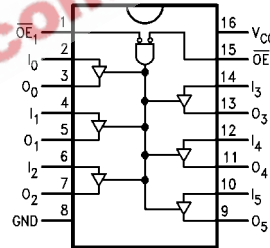

Function Table

Inputs			Output
\overline{OE}_1	\overline{OE}_2	I	O
L	L	L	L
L	L	H	H
X	H	X	Z
H	X	X	Z

L = LOW Voltage Level
H = HIGH Voltage Level
X = Immaterial
Z = High Impedance

Unit Loading/Fan Out

Pin Names	Description	U.L. HIGH/LOW	Input I_{IH}/I_{IL} Output I_{OH}/I_{OL}
$\overline{OE}_1, \overline{OE}_2$	Output Enable Input (Active LOW)	1.0/0.033	20 μ A/20 μ A
I_n	Inputs	1.0/0.033	20 μ A/20 μ A
O_n	Outputs	600/106.6 (80)	-12 mA/64 mA (48 mA)

Absolute Maximum Ratings (Note 1)		Recommended Operating Conditions	
Storage Temperature	-65°C to +150°C	Free Air Ambient Temperature	0°C to +70°C
Ambient Temperature under Bias	-55°C to +125°C	Supply Voltage	+4.5V to +5.5V
Junction Temperature under Bias	-55°C to +150°C		
V _{CC} Pin Potential to Ground Pin	-0.5V to +7.0V		
Input Voltage (Note 2)	-0.5V to +7.0V		
Input Current (Note 2)	-30 mA to +5.0 mA		
Voltage Applied to Output			
in HIGH State (with V _{CC} = 0V)			
Standard Output	-0.5V to V _{CC}		
3-STATE Output	-0.5V to +5.5V		
Current Applied to Output			
in LOW State (Max)	twice the rated I _{OL} (mA)		

Note 1: Absolute maximum ratings are values beyond which the device may be damaged or have its useful life impaired. Functional operation under these conditions is not implied.

Note 2: Either voltage limit or current limit is sufficient to protect inputs.

DC Electrical Characteristics

Symbol	Parameter	Min	Typ	Max	Units	V _{CC}	Conditions
V _{IH}	Input HIGH Voltage	2.0			V		Recognized as a HIGH Signal
V _{IL}	Input LOW Voltage			0.8	V		Recognized as a LOW Signal
V _{CD}	Input Clamp Diode Voltage			-1.2	V	Min	I _{IN} = -18 mA
V _{OH}	Output HIGH Voltage	10% V _{CC} 2.4 10% V _{CC} 2.0 5% V _{CC} 2.7			V	Min	I _{OH} = -3 mA I _{OH} = -15 mA I _{OH} = -3 mA
V _{OL}	Output LOW Voltage	10% V _{CC}		0.55	V	Min	I _{OL} = 64 mA
I _{IH}	Input HIGH Current			20	μA	Max	V _{IN} = 2.7V
I _{BVI}	Input HIGH Current Breakdown Test			100	μA	0.0	V _{IN} = 7.0V
I _{IL}	Input LOW Current			-20	μA	Max	V _{IN} = 0.5V
I _{OZH}	Output Leakage Current			50	μA	Max	V _{OUT} = 2.7V
I _{OZL}	Output Leakage Current			-50	μA	Max	V _{OUT} = 0.5V
I _{OS}	Output Short-Circuit Current	-100		-225	mA	Max	V _{OUT} = 0V
I _{CEX}	Output HIGH Leakage Current			250	μA	Max	V _{OUT} = V _{CC}
I _{ZZ}	Bus Drainage Test			500	μA	0.0V	V _{OUT} = 5.25V
I _{CCH}	Power Supply Current		25	35	mA	Max	V _O = HIGH
I _{CCL}	Power Supply Current		44	62	mA	Max	V _O = LOW
I _{CCZ}	Power Supply Current		35	48	mA	Max	V _O = HIGH Z

AC Electrical Characteristics

Symbol	Parameter	T _A = +25°C V _{CC} = +5.0V C _L = 50 pF			T _A = -55°C to +125°C V _{CC} = +5.0V C _L = 50 pF		T _A = 0°C to +70°C V _{CC} = +5.0V C _L = 50 pF		Units
		Min	Typ	Max	Min	Max	Min	Max	
t _{PLH}	Propagation Delay	2.5	4.6	6.5	2.0	7.0	2.0	7.0	ns
t _{PHL}	I _n to O _n	2.5	4.9	7.0	2.0	7.0	2.0	7.5	
t _{PZH}	Enable Time	2.5	5.1	9.5	2.0	8.5	2.5	10.0	ns
t _{PZL}		2.5	5.7	9.0	2.0	8.5	2.5	9.5	
t _{PHZ}	Disable Time	2.0	3.6	6.5	1.5	6.5	2.0	7.0	ns
t _{PLZ}		2.0	4.4	6.5	1.5	9.0	2.0	7.0	

Physical Dimensions inches (millimeters) unless otherwise noted

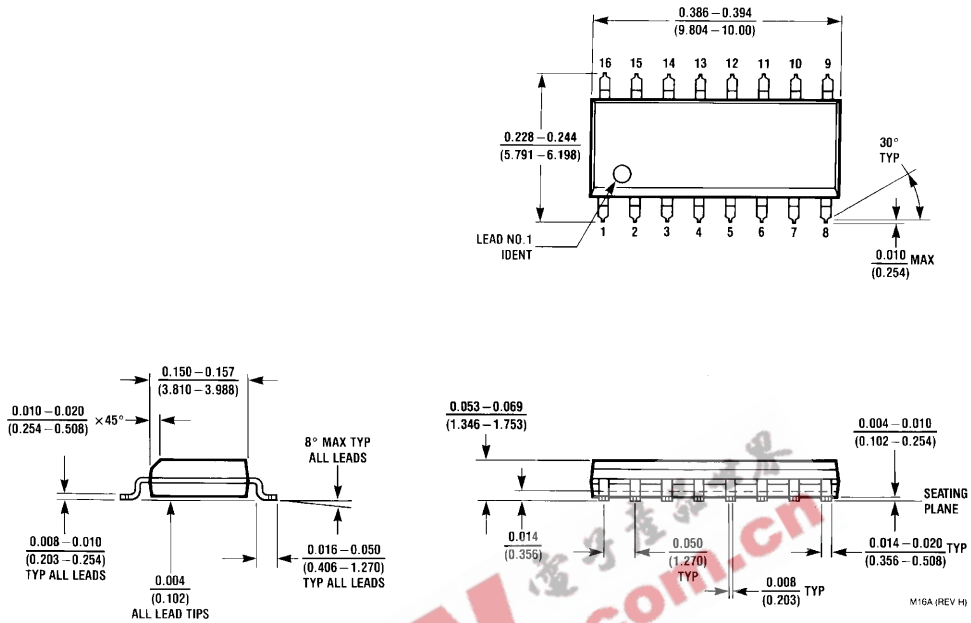

16-Lead (0.150" Wide) Molded Small Outline Package, JEDEC (S)
Package Number M16A

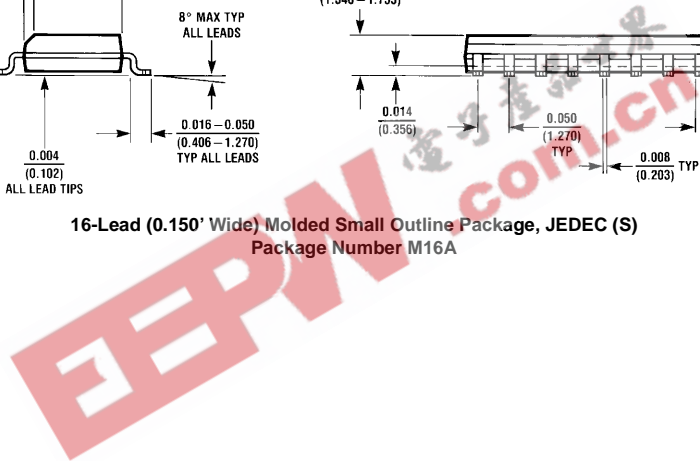

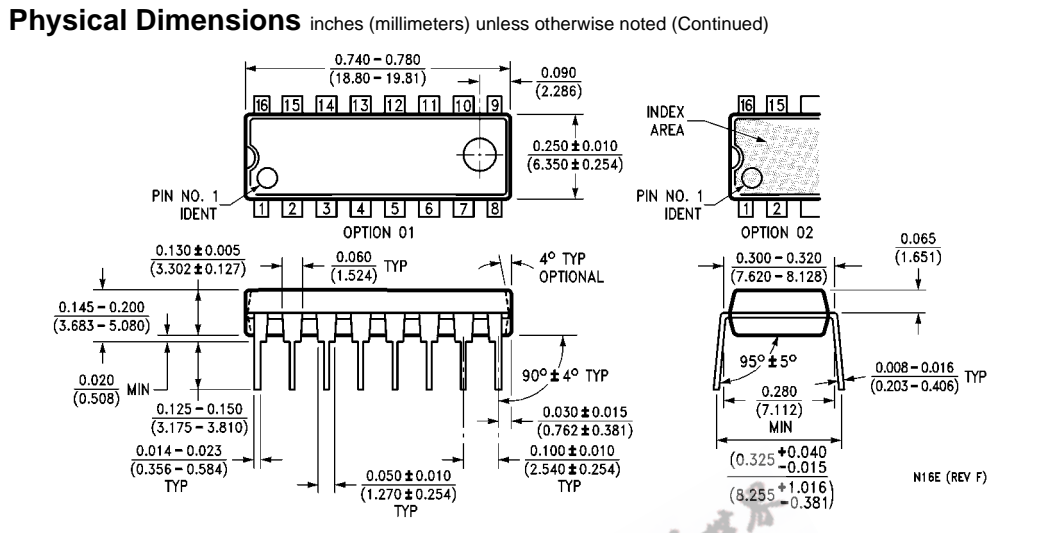

Fairchild does not assume any responsibility for use of any circuitry described, no circuit patent licenses are implied and Fairchild reserves the right at any time without notice to change said circuitry and specifications.

LIFE SUPPORT POLICY

FAIRCHILD'S PRODUCTS ARE NOT AUTHORIZED FOR USE AS CRITICAL COMPONENTS IN LIFE SUPPORT DEVICES OR SYSTEMS WITHOUT THE EXPRESS WRITTEN APPROVAL OF THE PRESIDENT OF FAIRCHILD SEMICONDUCTOR CORPORATION. As used herein:

1. Life support devices or systems are devices or systems which, (a) are intended for surgical implant into the body, or (b) support or sustain life, and (c) whose failure to perform when properly used in accordance with instructions for use provided in the labeling, can be reasonably expected to result in a significant injury to the user.
2. A critical component in any component of a life support device or system whose failure to perform can be reasonably expected to cause the failure of the life support device or system, or to affect its safety or effectiveness.

www.fairchildsemi.com