

DATA SHEET

For a complete data sheet, please also download:

- The IC06 74HC/HCT/HCU/HCMOS Logic Family Specifications
- The IC06 74HC/HCT/HCU/HCMOS Logic Package Information
- The IC06 74HC/HCT/HCU/HCMOS Logic Package Outlines

EEPW 电子产品世界
.com.cn

74HC/HCT138

3-to-8 line decoder/demultiplexer;
inverting

Product specification
File under Integrated Circuits, IC06

September 1993

3-to-8 line decoder/demultiplexer; inverting

74HC/HCT138

FEATURES

- Demultiplexing capability
- Multiple input enable for easy expansion
- Ideal for memory chip select decoding
- Active LOW mutually exclusive outputs
- Output capability: standard
- I_{CC} category: MSI

GENERAL DESCRIPTION

The 74HC/HCT138 are high-speed Si-gate CMOS devices and are pin compatible with low power Schottky TTL (LSTTL). They are specified in compliance with JEDEC standard no. 7A.

The 74HC/HCT138 decoders accept three binary weighted address inputs (A₀, A₁, A₂) and when enabled, provide 8 mutually exclusive active LOW outputs (\bar{Y}_0 to \bar{Y}_7).

The "138" features three enable inputs: two active LOW (\bar{E}_1 and \bar{E}_2) and one active HIGH (E₃). Every output will be HIGH unless \bar{E}_1 and \bar{E}_2 are LOW and E₃ is HIGH.

This multiple enable function allows easy parallel expansion of the "138" to a 1-of-32 (5 lines to 32 lines) decoder with just four "138" ICs and one inverter.

The "138" can be used as an eight output demultiplexer by using one of the active LOW enable inputs as the data input and the remaining enable inputs as strobes. Unused enable inputs must be permanently tied to their appropriate active HIGH or LOW state.

The "138" is identical to the "238" but has inverting outputs.

QUICK REFERENCE DATA

GND = 0 V; T_{amb} = 25 °C; t_r = t_f = 6 ns

SYMBOL	PARAMETER	CONDITIONS	TYPICAL		UNIT
			HC	HCT	
t _{PHL} / t _{PLH}	propagation delay A _n to \bar{Y}_n	C _L = 15 pF; V _{CC} = 5 V	12	17	ns
t _{PHL} / t _{PLH}	E ₃ to \bar{Y}_n \bar{E}_n to \bar{Y}_n		14	19	ns
C _I	input capacitance		3.5	3.5	pF
C _{PD}	power dissipation capacitance per package	notes 1 and 2	67	67	pF

Notes

1. C_{PD} is used to determine the dynamic power dissipation (P_D in μW):

$$P_D = C_{PD} \times V_{CC}^2 \times f_i + \sum (C_L \times V_{CC}^2 \times f_o) \text{ where:}$$

f_i = input frequency in MHz

f_o = output frequency in MHz

$\sum (C_L \times V_{CC}^2 \times f_o)$ = sum of outputs

C_L = output load capacitance in pF

V_{CC} = supply voltage in V

2. For HC the condition is V_I = GND to V_{CC}
For HCT the condition is V_I = GND to V_{CC} - 1.5 V

ORDERING INFORMATION

See "74HC/HCT/HCU/HCMOS Logic Package Information".

3-to-8 line decoder/demultiplexer; inverting

74HC/HCT138

PIN DESCRIPTION

PIN NO.	SYMBOL	NAME AND FUNCTION
1, 2, 3	A ₀ to A ₂	address inputs
4, 5	\bar{E}_1, \bar{E}_2	enable inputs (active LOW)
6	E ₃	enable input (active HIGH)
8	GND	ground (0 V)
15, 14, 13, 12, 11, 10, 9, 7	\bar{Y}_0 to \bar{Y}_7	outputs (active LOW)
16	V _{CC}	positive supply voltage

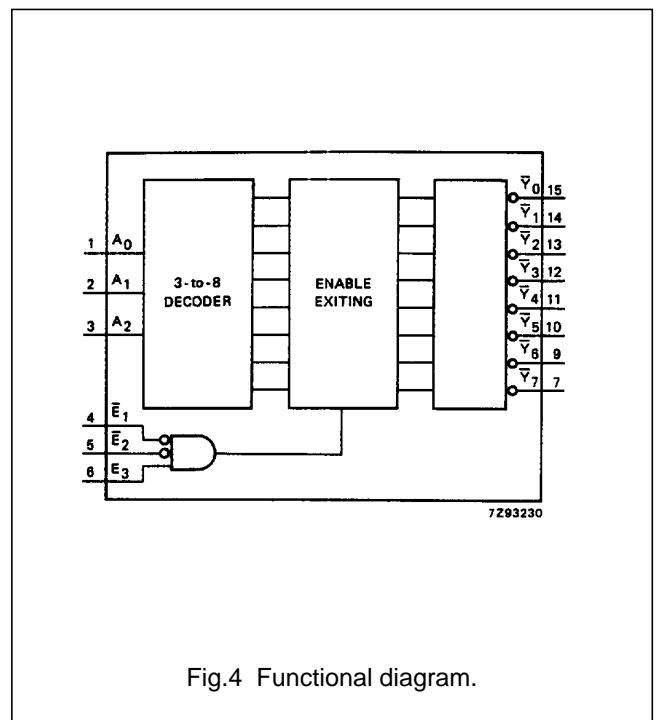
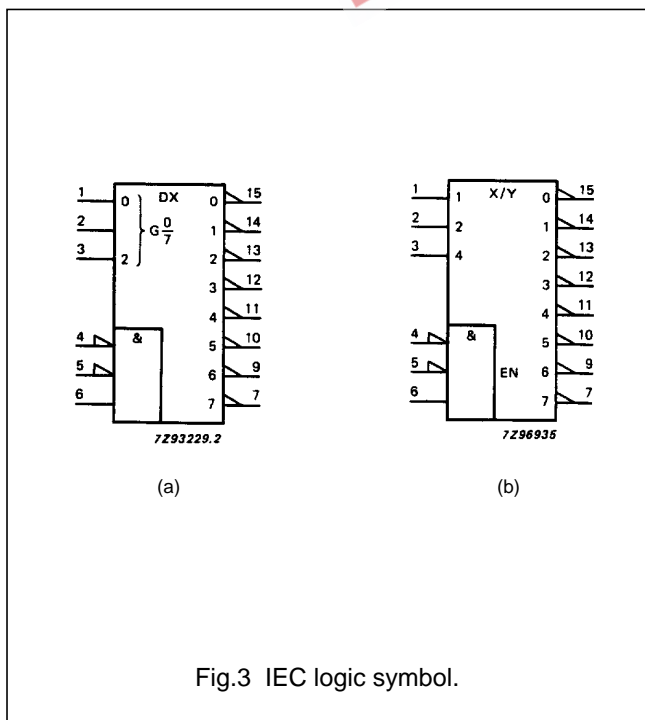
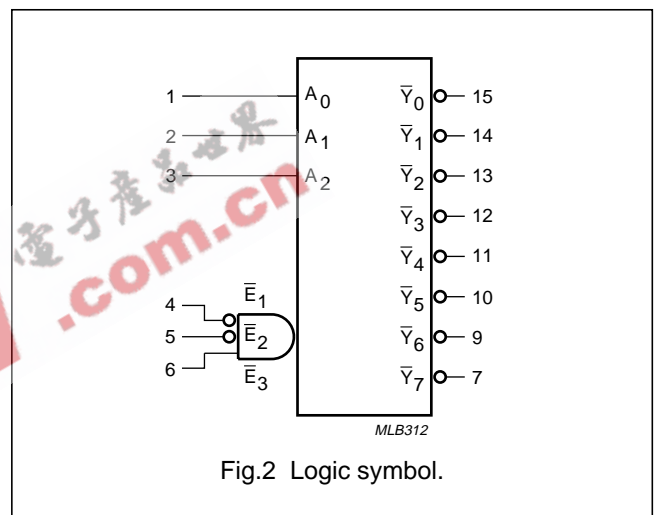
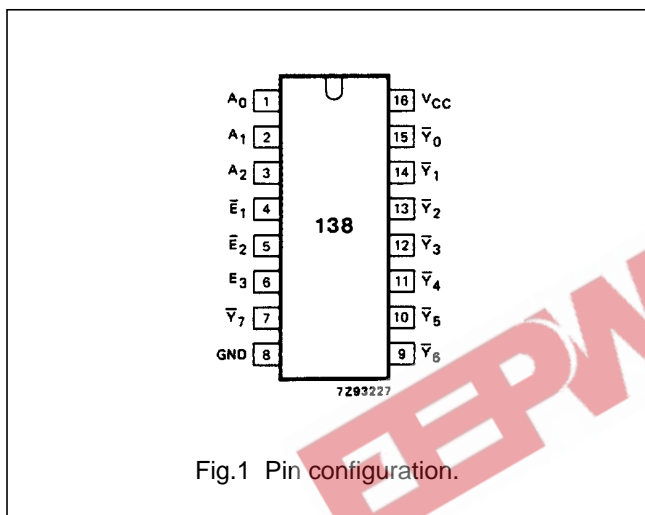

3-to-8 line decoder/demultiplexer; inverting

74HC/HCT138

FUNCTION TABLE

INPUTS						OUTPUTS							
\bar{E}_1	\bar{E}_2	E_3	A_0	A_1	A_2	\bar{Y}_0	\bar{Y}_1	\bar{Y}_2	\bar{Y}_3	\bar{Y}_4	\bar{Y}_5	\bar{Y}_6	\bar{Y}_7
H	X	X	X	X	X	H	H	H	H	H	H	H	H
X	H	X	X	X	X	H	H	H	H	H	H	H	H
X	X	L	X	X	X	H	H	H	H	H	H	H	H
L	L	H	L	L	L	L	H	H	H	H	H	H	H
L	L	H	H	L	L	H	L	H	H	H	H	H	H
L	L	H	L	H	L	H	H	L	H	H	H	H	H
L	L	H	H	H	L	H	H	H	L	H	H	H	H
L	L	H	L	L	H	H	H	H	H	L	H	H	H
L	L	H	H	L	H	H	H	H	H	H	L	H	H
L	L	H	L	H	H	H	H	H	H	H	H	L	H
L	L	H	H	H	H	H	H	H	H	H	H	H	L

Notes

- 1. H = HIGH voltage level
- L = LOW voltage level
- X = don't care

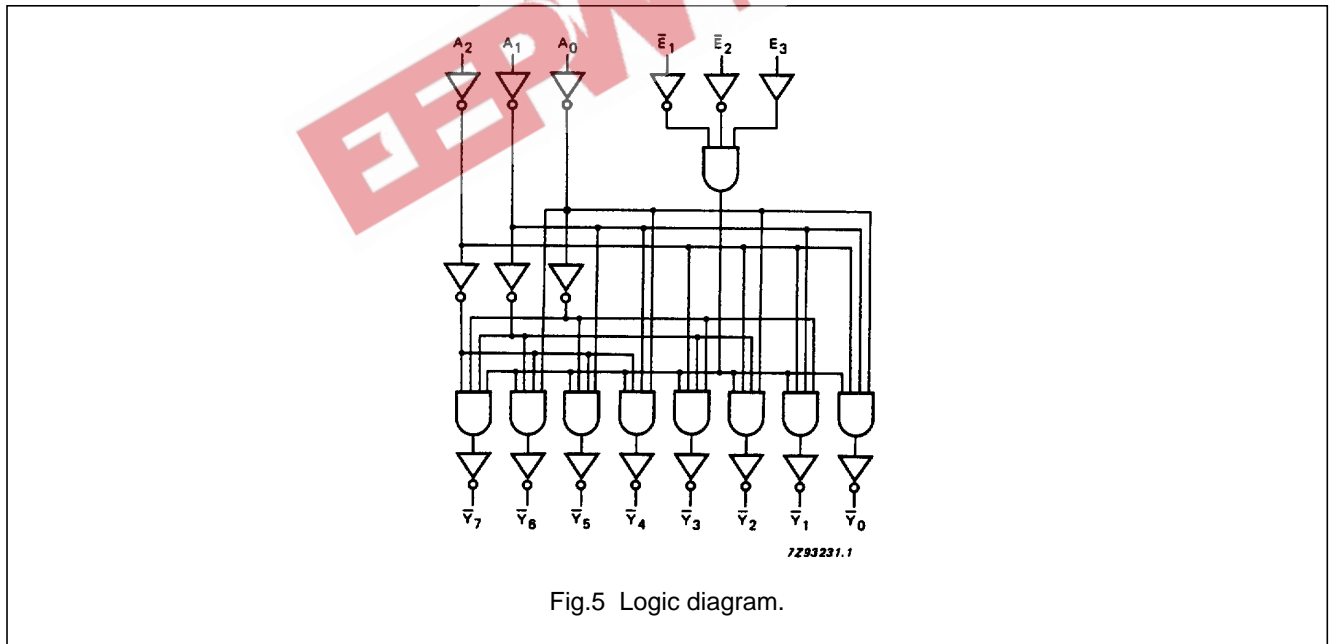

Fig.5 Logic diagram.

3-to-8 line decoder/demultiplexer; inverting

74HC/HCT138

DC CHARACTERISTICS FOR 74HC

For the DC characteristics see *"74HC/HCT/HCU/HCMOS Logic Family Specifications"*.

Output capability: standard

I_{CC} category: MSI

AC CHARACTERISTICS FOR 74HC

GND = 0 V; t_r = t_f = 6 ns; C_L = 50 pF

SYMBOL	PARAMETER	T _{amb} (°C)						UNIT	TEST CONDITIONS		
		74HC							V _{CC} (V)	WAVEFORMS	
		+25			-40 to +85		-40 to +125				
		min.	typ.	max.	min.	max.	min.				max.
t _{PHL} / t _{PLH}	propagation delay A _n to \bar{Y}_n		41 15 12	150 30 26		190 38 33		225 45 38	ns	2.0 4.5 6.0	Fig.6
t _{PHL} / t _{PLH}	propagation delay E ₃ to \bar{Y}_n		47 17 14	150 30 26		190 38 33		225 45 38	ns	2.0 4.5 6.0	Fig.6
t _{PHL} / t _{PLH}	propagation delay \bar{E}_n to \bar{Y}_n		47 17 14	150 30 26		190 38 33		225 45 38	ns	2.0 4.5 6.0	Fig.7
t _{THL} / t _{TLH}	output transition time		19 7 6	75 15 13		95 19 16		110 22 19	ns	2.0 4.5 6.0	Figs 6 and 7

3-to-8 line decoder/demultiplexer; inverting

74HC/HCT138

DC CHARACTERISTICS FOR 74HCT

For the DC characteristics see *"74HC/HCT/HCU/HCMOS Logic Family Specifications"*.

Output capability: standard

I_{CC} category: MSI

Note to HCT types

The value of additional quiescent supply current (ΔI_{CC}) for a unit load of 1 is given in the family specifications. To determine ΔI_{CC} per input, multiply this value by the unit load coefficient shown in the table below.

INPUT	UNIT LOAD COEFFICIENT
A _n	1.50
\bar{E}_n	1.25
E ₃	1.00

AC CHARACTERISTICS FOR 74HCT

GND = 0 V; t_r = t_f = 6 ns; C_L = 50 pF

SYMBOL	PARAMETER	T _{amb} (°C)							UNIT	TEST CONDITIONS	
		74HCT								V _{CC} (V)	WAVEFORMS
		+25			-40 to +85		-40 to +125				
		min.	typ.	max.	min.	max.	min.	max.			
t _{PHL} / t _{PLH}	propagation delay A _n to \bar{Y}_n		20	35		44		53	ns	4.5	Fig.6
t _{PHL} / t _{PLH}	propagation delay E ₃ to \bar{Y}_n		18	40		50		60	ns	4.5	Fig.6
t _{PHL} / t _{PLH}	propagation delay \bar{E}_n to \bar{Y}_n		19	40		50		60	ns	4.5	Fig.7
t _{THL} / t _{TLH}	output transition time		7	15		19		22	ns	4.5	Figs 6 and 7

3-to-8 line decoder/demultiplexer; inverting

74HC/HCT138

AC WAVEFORMS

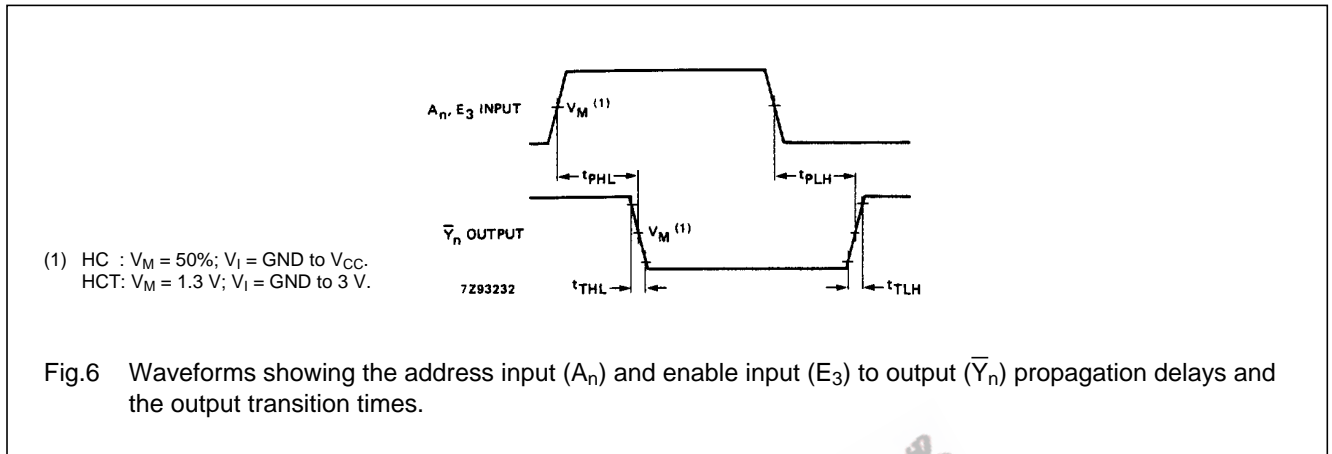

Fig.6 Waveforms showing the address input (A_n) and enable input (E_3) to output (\bar{Y}_n) propagation delays and the output transition times.

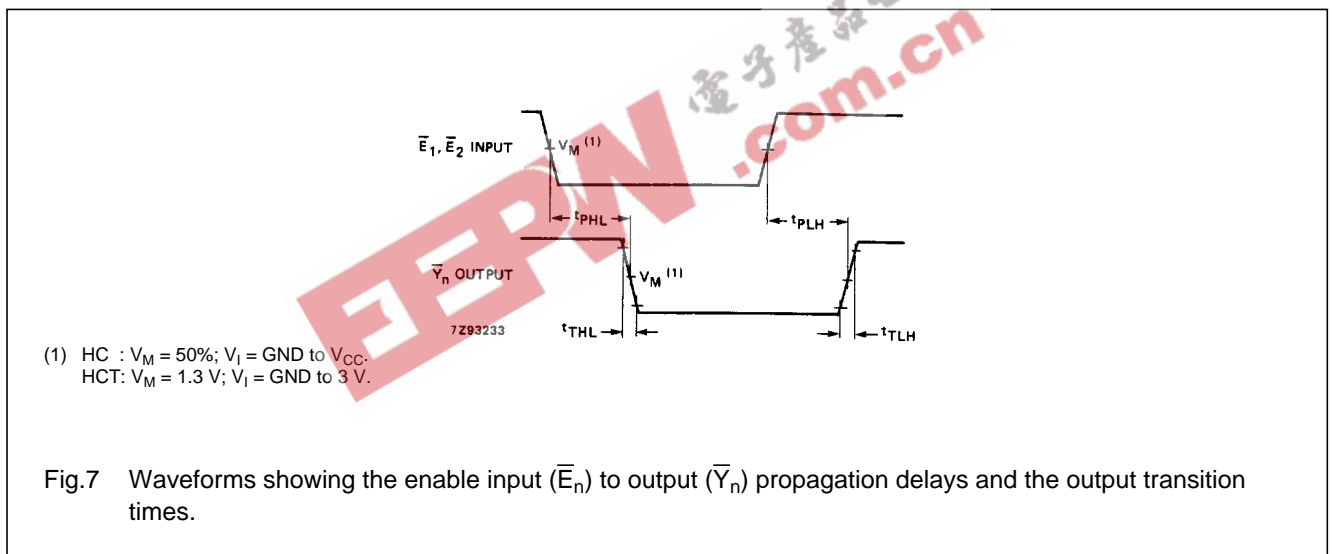

Fig.7 Waveforms showing the enable input (\bar{E}_n) to output (\bar{Y}_n) propagation delays and the output transition times.

PACKAGE OUTLINES

See "74HC/HCT/HCU/HCMOS Logic Package Outlines".