

74AC240, 74ACT240 Octal Buffer/Line Driver with 3-STATE Outputs

General Description

The AC/ACT240 is an octal buffer and line driver designed to be employed as a memory address driver, clock driver and bus oriented transmitter or receiver which provides improved PC board density.

Features

- I_{CC} and I_{OZ} reduced by 50%
- Inverting 3-STATE outputs drive bus lines or buffer memory address registers
- Outputs source/sink 24mA
- ACT240 has TTL-compatible inputs

Ordering Information

Order Number	Package Number	Package Description
74AC240SC	M20B	20-Lead Small Outline Integrated Circuit (SOIC), JEDEC MS-013, 0.300" Wide
74AC240SJ	M20D	20-Lead Small Outline Package (SOP), EIAJ TYPE II, 5.3mm Wide
74AC240MTC	MTC20	20-Lead Thin Shrink Small Outline Package (TSSOP), JEDEC MO-153, 4.4mm Wide
74AC240PC	N20A	20-Lead Plastic Dual-In-Line Package (PDIP), JEDEC MS-001, 0.300" Wide
74ACT240SC	M20B	20-Lead Small Outline Integrated Circuit (SOIC), JEDEC MS-013, 0.300" Wide
74ACT240SC_NL ⁽¹⁾	M20B	Pb-Free 20-Lead Small Outline Integrated Circuit (SOIC), JEDEC MS-013, 0.300" Wide
74ACT240SJ	M20D	20-Lead Small Outline Package (SOP), EIAJ TYPE II, 5.3mm Wide
74ACT240MTC	MTC20	20-Lead Thin Shrink Small Outline Package (TSSOP), JEDEC MO-153, 4.4mm Wide
74ACT240PC	N20A	20-Lead Plastic Dual-In-Line Package (PDIP), JEDEC MS-001, 0.300" Wide
74ACT240PC_NL ⁽¹⁾	N20A	Pb-Free 20-Lead Plastic Dual-In-Line Package (PDIP), JEDEC MS-001, 0.300" Wide

Device also available in Tape and Reel. Specify by appending suffix letter "X" to the ordering code.
Pb-Free package per JEDEC J-STD-020B.

Note:

1. "_NL" indicates Pb-Free package (per JEDEC J-STD-020B). Please use order number as indicated.

FACT™ is a trademark of Fairchild Semiconductor Corporation.

Logic Symbol

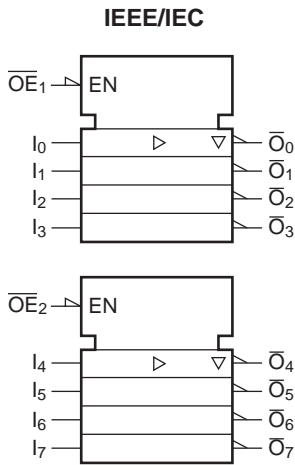

Pin Descriptions

Pin Names	Description
$\overline{OE}_1, \overline{OE}_2$	3-STATE Output Enable Inputs
I_0-I_7	Inputs
$\overline{O}_0-\overline{O}_7$	Outputs

Truth Tables

Inputs		Outputs (Pins 12, 14, 16, 18)
\overline{OE}_1	I_n	
L	L	H
L	H	L
H	X	Z

Connection Diagram

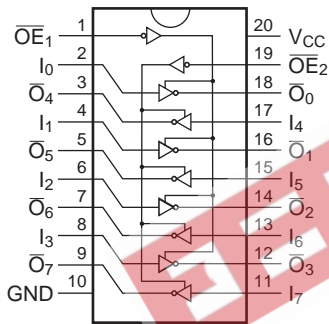

Inputs		Outputs (Pins 3, 5, 7, 9)
\overline{OE}_2	I_n	
L	L	H
L	H	L
H	X	Z

H = HIGH Voltage Level
 L = LOW Voltage Level
 X = Immaterial
 Z = High Impedance

Absolute Maximum Ratings

The "Absolute Maximum Ratings" are those values beyond which the safety of the device cannot be guaranteed. The device should not be operated at these limits. The parametric values defined in the Electrical Characteristics tables are not guaranteed at the absolute maximum ratings. The "Recommended Operating Conditions" table will define the conditions for actual device operation.

Symbol	Parameter	Value	Units
V_{CC}	Supply Voltage	-0.5 to +7.0	V
I_{IK}	DC Input Diode Current $V_I = -0.5V$ $V_I = V_{CC} + 0.5V$	-20 +20	mA
V_I	DC Input Voltage	-0.5 to $V_{CC} + 0.5$	V
I_{OK}	DC Output Diode Current $V_O = -0.5V$ $V_O = V_{CC} + 0.5V$	-20 +20	mA
V_O	DC Output Voltage	-0.5 to $V_{CC} + 0.5$	V
I_O	DC Output Source or Sink Current	± 50	mA
I_{CC} or I_{GND}	DC V_{CC} or Ground Current per Output Pin	± 50	mA
T_{STG}	Storage Temperature	-65°C to +150°C	°C
T_J	Junction Temperature, PDIP	140°	°C

Recommended Operating Conditions

Symbol	Parameter	Value	Units
V_{CC}	Supply Voltage AC ACT	2.0 to 6.0 4.5 to 5.5	V
V_I	Input Voltage	0 to V_{CC}	V
V_O	Output Voltage	0 to V_{CC}	V
T_A	Operating Temperature	-40 to +85°	°C
$\Delta V/\Delta t$	Minimum Input Edge Rate AC Devices, V_{IN} from 30% to 70% of V_{CC} V_{CC} @ 3.3V, 4.5V, 5.5V	125	mV/ns
$\Delta V/\Delta t$	Minimum Input Edge Rate ACT Devices, V_{IN} from 0.8V to 2.0V V_{CC} @ 4.5V, 5.5V	125	mV/ns

DC Electrical Characteristics for AC

Symbol	Parameter	Conditions	V _{CC} (V)	T _A = +25°C		T _A = -40°C to +85°C		Units
				Typ.	Guaranteed Limits			
V _{IH}	Minimum HIGH Level Input Voltage	V _{OUT} = 0.1V or V _{CC} - 0.1V	3.0	1.5	2.1	2.1	V	
			4.5	2.25	3.15	3.15		
			5.5	2.75	3.85	3.85		
V _{IL}	Maximum LOW Level Input Voltage	V _{OUT} = 0.1V or V _{CC} - 0.1V	3.0	1.5	0.9	0.9	V	
			4.5	2.25	1.35	1.35		
			5.5	2.75	1.65	1.65		
V _{OH}	Minimum HIGH Level Output Voltage	I _{OUT} = -50μA	3.0	2.99	2.9	2.9	V	
			4.5	4.49	4.4	4.4		
			5.5	5.49	5.4	5.4		
		V _{IN} = V _{IL} or V _{IH} I _{OH} = -12mA	3.0		2.56	2.46		
		I _{OH} = -24mA	4.5		3.86	3.76		
I _{OH} = -24mA ⁽²⁾	5.5		4.86	4.76				
V _{OL}	Maximum LOW Level Output Voltage	I _{OUT} = 50μA	3.0	0.002	0.1	0.1	V	
			4.5	0.001	0.1	0.1		
			5.5	0.001	0.1	0.1		
		V _{IN} = V _{IL} or V _{IH} I _{OL} = 12mA	3.0		0.36	0.44		
		I _{OL} = 24mA	4.5		0.36	0.44		
I _{OL} = 24mA ⁽²⁾	5.5		0.36	0.44				
I _{IN} ⁽⁴⁾	Maximum Input Leakage Current	V _I = V _{CC} , GND	5.5		± 0.1	± 1.0	μA	
I _{OZ}	Maximum 3-STATE Leakage Current	V _I (OE) = V _{IL} , V _{IH} V _I = V _{CC} , GND V _O = V _{CC} , GND	5.5		± 0.25	± 2.5	μA	
I _{OLD}	Minimum Dynamic Output Current ⁽³⁾	V _{OLD} = 1.65V Max	5.5			75	mA	
I _{OHD}		V _{OHD} = 3.85V Min	5.5			-75	mA	
I _{CC} ⁽⁴⁾	Maximum Quiescent Supply Current	V _{IN} = V _{CC} or GND	5.5		4.0	40.0	μA	

Notes:

- All outputs loaded; thresholds on input associated with output under test.
- Maximum test duration 2.0ms, one output loaded at a time.
- I_{IN} and I_{CC} @ 3.0V are guaranteed to be less than or equal to the respective limit @ 5.5V V_{CC}.

DC Electrical Characteristics for ACT

Symbol	Parameter	Conditions	V _{CC} (V)	T _A = +25°C		T _A = -40°C to +85°C		Units
				Typ	Guaranteed Limits			
V _{IH}	Minimum HIGH Level Input Voltage	V _{OUT} = 0.1V or V _{CC} - 0.1V	4.5	1.5	2.0	2.0		V
			5.5	1.5	2.0	2.0		
V _{IL}	Maximum LOW Level Input Voltage	V _{OUT} = 0.1V or V _{CC} - 0.1V	4.5	1.5	0.8	0.8		V
			5.5	1.5	0.8	0.8		
V _{OH}	Minimum HIGH Level Output Voltage	I _{OUT} = -50μA	4.5	4.49	4.4	4.4		V
			5.5	5.49	5.4	5.4		
		V _{IN} = V _{IL} or V _{IH} I _{OH} = -24mA	4.5		3.86	3.76		
		I _{OH} = -24mA ⁽⁵⁾	5.5		4.86	4.76		
V _{OL}	Maximum LOW Level Output Voltage	I _{OUT} = 50μA	4.5	0.001	0.1	0.1		V
			5.5	0.001	0.1	0.1		
		V _{IN} = V _{IL} or V _{IH} I _{OL} = 24mA	4.5		0.36	0.44		
		I _{OL} = 24mA ⁽⁵⁾	5.5		0.36	0.44		
I _{IN}	Maximum Input Leakage Current	V _I = V _{CC} , GND	5.5		±0.1	±1.0		μA
I _{OZ}	Maximum 3-STATE Leakage Current	V _I = V _{IL} , V _{IH} , V _O = V _{CC} , GND	5.5		±0.25	±2.5		μA
I _{CCT}	Maximum I _{CC} /Input	V _I = V _{CC} - 2.1V	5.5	0.6		1.5		mA
I _{OLD}	Minimum Dynamic Output Current ⁽⁶⁾	V _{OLD} = 1.65V Max	5.5			75		mA
I _{OHD}		V _{OHD} = 3.85V Min	5.5			-75		mA
I _{CC}	Maximum Quiescent Supply Current	V _{IN} = V _{CC} or GND	5.5		4.0	40.0		μA

Notes:

- All outputs loaded; thresholds on input associated with output under test.
- Maximum test duration 2.0 ms, one output loaded at a time.

AC Electrical Characteristics for AC

Symbol	Parameter	V _{CC} (V) ⁽⁷⁾	T _A =					Units
			+25°C			-40°C to +85°C		
			C _L = 50 pF			C _L = 50 pF		
			Min.	Typ.	Max.	Min.	Max.	
t _{PLH}	Propagation Delay Data to Output	3.3	1.5	6.0	8.0	1.0	9.0	ns
		5.0	1.5	4.5	6.5	1.0	7.0	
t _{PHL}	Propagation Delay Data to Output	3.3	1.5	5.5	8.0	1.0	8.5	ns
		5.0	1.5	4.5	6.0	1.0	6.5	
t _{PZH}	Output Enable Time	3.3	1.5	6.0	10.5	1.0	11.0	ns
		5.0	1.5	5.0	7.0	1.0	8.0	
t _{PZL}	Output Enable Time	3.3	1.5	7.0	10.0	1.0	11.0	ns
		5.0	1.5	5.5	8.0	1.0	8.5	
t _{PHZ}	Output Disable Time	3.3	1.5	7.0	10.0	1.0	10.5	ns
		5.0	1.5	6.5	9.0	1.0	9.5	
t _{PLZ}	Output Disable Time	3.3	1.5	7.5	10.5	1.0	11.5	ns
		5.0	1.5	6.5	9.0	1.0	9.5	

Notes:

7. Voltage Range 3.3 is 3.3V ± 0.3V, Voltage Range 5.0 is 5.0V ± 0.5V

AC Electrical Characteristics for ACT

Symbol	Parameter	V _{CC} (V) ⁽⁸⁾	T _A =					Units
			+25°C			-40°C to +85°C		
			C _L = 50 pF			C _L = 50 pF		
			Min.	Typ.	Max.	Min.	Max.	
t _{PLH}	Propagation Delay Data to Output	5.0	1.5	6.0	8.5	1.5	9.5	ns
t _{PHL}	Propagation Delay Data to Output	5.0	1.5	5.5	7.5	1.5	8.5	ns
t _{PZH}	Output Enable Time	5.0	1.5	7.0	8.5	1.0	9.5	ns
t _{PZL}	Output Enable Time	5.0	2.0	7.0	9.5	1.5	10.5	ns
t _{PHZ}	Output Disable Time	5.0	2.0	8.0	9.5	2.0	10.5	ns
t _{PLZ}	Output Disable Time	5.0	2.5	6.5	10.0	2.0	10.5	ns

Notes:

8. Voltage Range 5.0 is 5.0V ± 0.5V

Capacitance

Symbol	Parameter	Conditions	Typ.	Units
C _{IN}	Input Capacitance	V _{CC} = OPEN	4.5	pF
C _{PD}	Power Dissipation Capacitance	V _{CC} = 5.0V	45.0	pF

Physical Dimensions inches (millimeters) unless otherwise noted

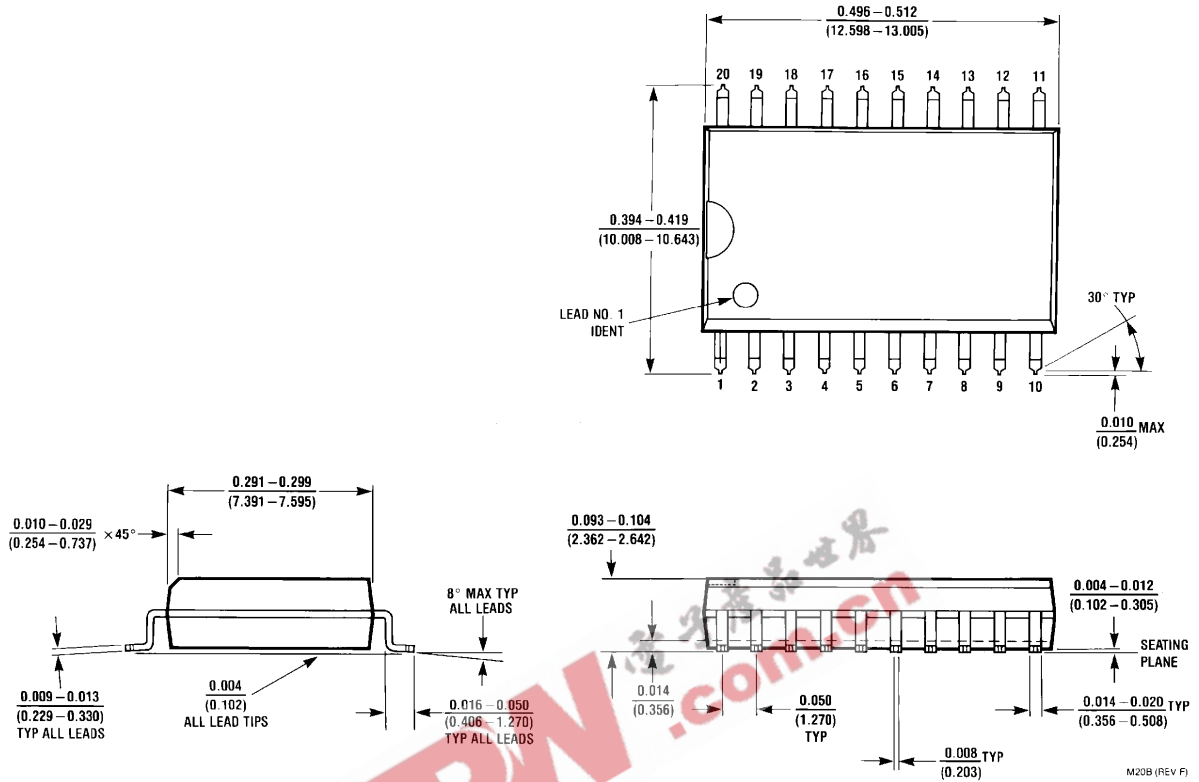

**20-Lead Small Outline Integrated Circuit (SOIC),
JEDEC MS-013, 0.300" Wide Package Number M20B**

Physical Dimensions (Continued) millimeters unless otherwise noted

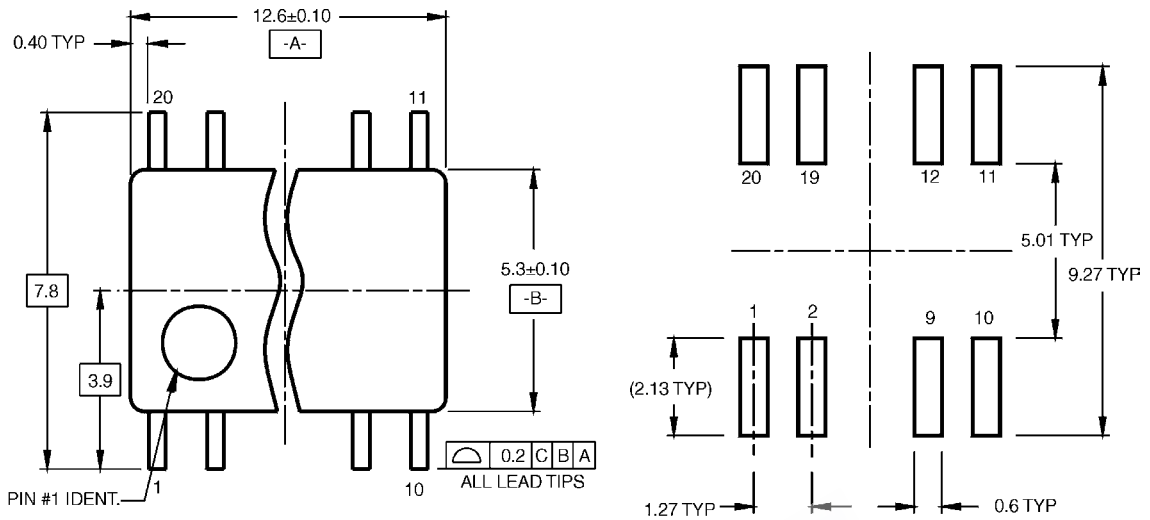

LAND PATTERN RECOMMENDATION

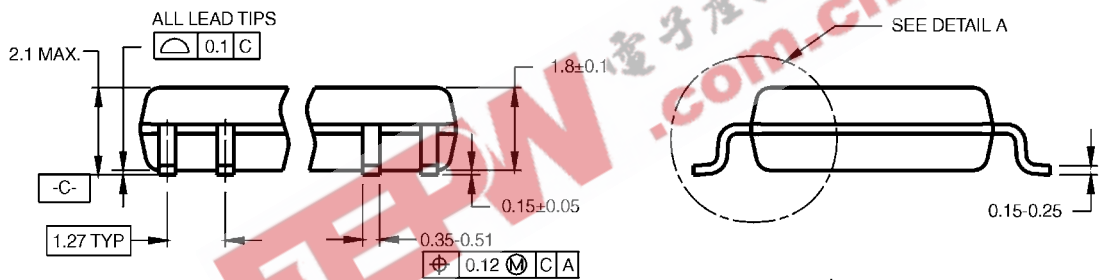

DIMENSIONS ARE IN MILLIMETERS

- NOTES:
- A. CONFORMS TO EIAJ EDR-7320 REGISTRATION, ESTABLISHED IN DECEMBER, 1998.
 - B. DIMENSIONS ARE IN MILLIMETERS.
 - C. DIMENSIONS ARE EXCLUSIVE OF BURRS, MOLD FLASH, AND TIE BAR EXTRUSIONS.

M20DRvB1

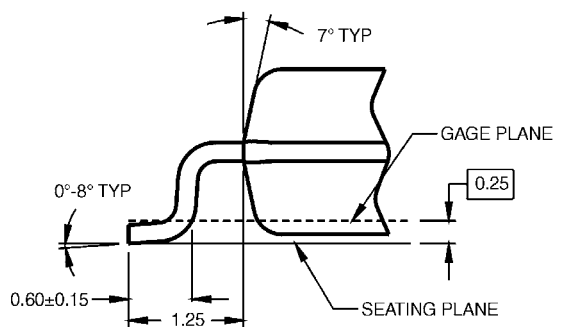

DETAIL A

**Pb-Free 20-Lead Small Outline Package (SOP),
EIAJ TYPE II, 5.3mm Wide Package Number M20D**

Physical Dimensions (Continued) millimeters unless otherwise noted

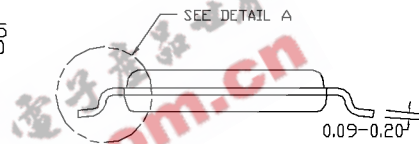
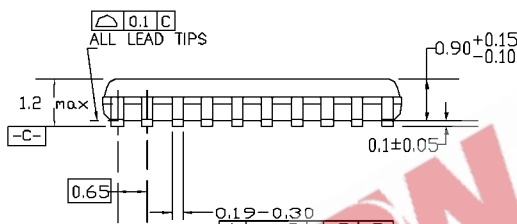
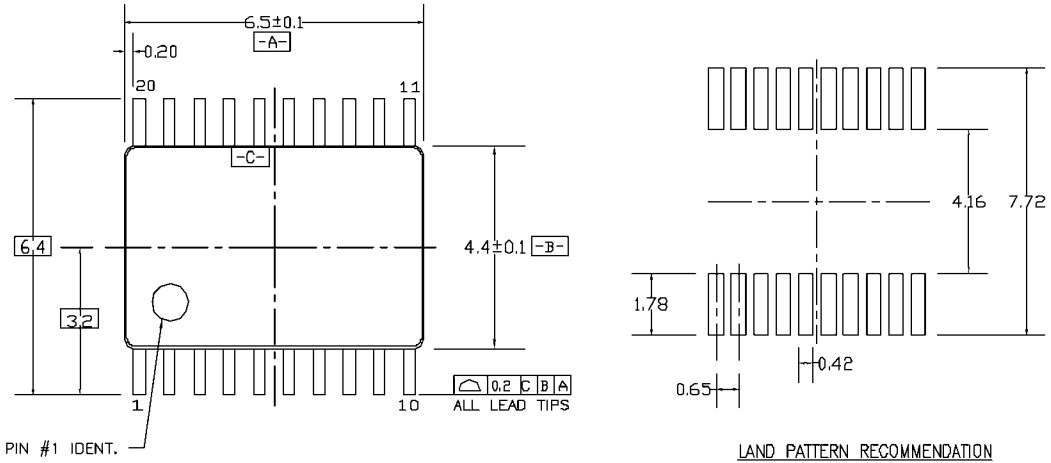

DIMENSIONS ARE IN MILLIMETERS

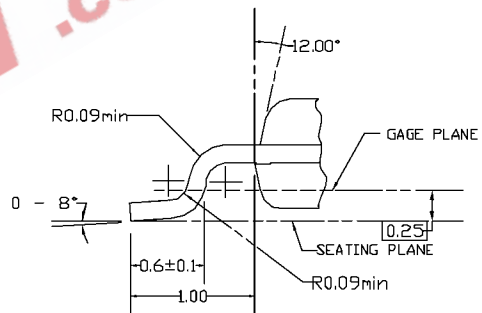

NOTES:

- A. CONFORMS TO JEDEC REGISTRATION MO-153, VARIATION AC, REF NOTE 6, DATE 7/93.
- B. DIMENSIONS ARE IN MILLIMETERS.
- C. DIMENSIONS ARE EXCLUSIVE OF BURRS, MOLDS FLASH, AND TIE BAR EXTRUSIONS.
- D. DIMENSIONS AND TOLERANCES PER ANSI Y14.5M, 1982.

MTC20REV D1

**20-Lead Thin Shrink Small Outline Package (TSSOP),
JEDEC MO-153, 4.4mm Wide Package Number MTC20**

Physical Dimensions (Continued) inches (millimeters) unless otherwise noted

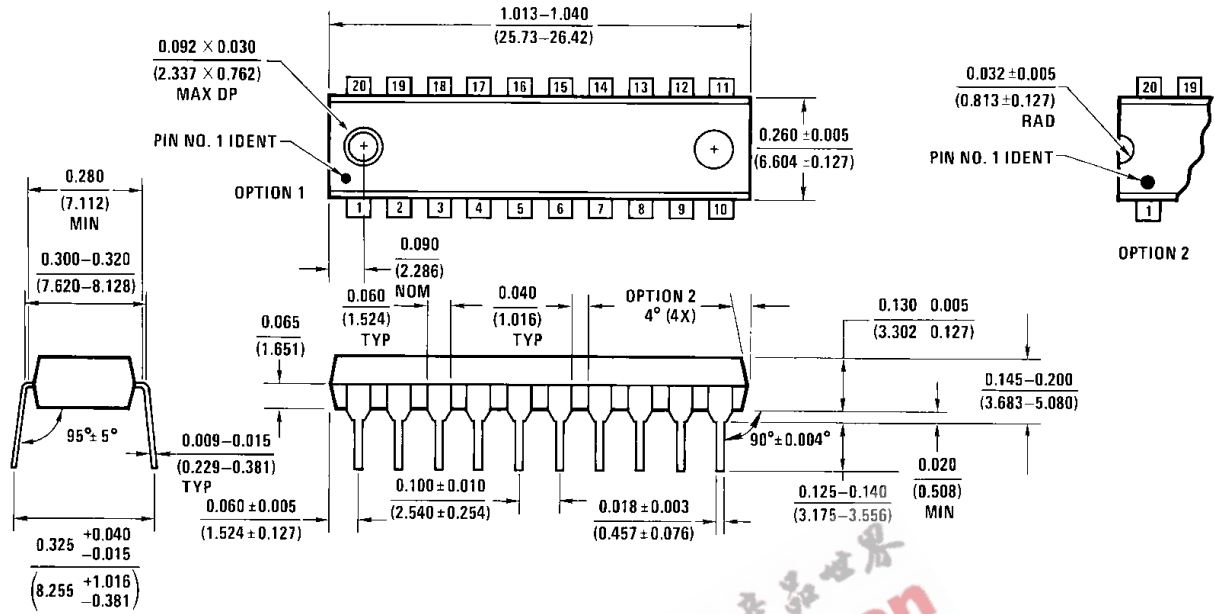

N20A (REV G)

20-Lead Plastic Dual-In-Line Package (PDIP),
JEDEC MS-001, 0.300" Wide Package Number N20A

EEPW.COM.CN

TRADEMARKS

The following are registered and unregistered trademarks Fairchild Semiconductor owns or is authorized to use and is not intended to be an exhaustive list of all such trademarks.

ACEx™	FAST®	ISOPLANAR™	PowerSaver™	SuperSOT™-6
ActiveArray™	FASTr™	LittleFET™	PowerTrench®	SuperSOT™-8
Bottomless™	FPST™	MICROCOUPLER™	QFET®	SyncFET™
Build it Now™	FRFET™	MicroFET™	QS™	TCM™
CoolFET™	GlobalOptoisolator™	MicroPak™	QT Optoelectronics™	TinyLogic®
CROSSVOLT™	GTO™	MICROWIRE™	Quiet Series™	TINYOPTO™
DOME™	HiSeC™	MSX™	RapidConfigure™	TruTranslation™
EcoSPARK™	I ² C™	MSXPro™	RapidConnect™	UHC™
E ² CMOST™	i-Lo™	OCX™	μSerDes™	UltraFET®
EnSigna™	ImpliedDisconnect™	OCXPro™	ScalarPump™	UniFET™
FACT™	IntelliMAX™	OPTOLOGIC®	SILENT SWITCHER®	VCX™
FACT Quiet Series™		OPTOPLANAR™	SMART START™	Wire™
Across the board. Around the world.™		PACMAN™	SPM™	
The Power Franchise®		POP™	Stealth™	
Programmable Active Droop™		Power247™	SuperFET™	
		PowerEdge™	SuperSOT™-3	

DISCLAIMER

FAIRCHILD SEMICONDUCTOR RESERVES THE RIGHT TO MAKE CHANGES WITHOUT FURTHER NOTICE TO ANY PRODUCTS HEREIN TO IMPROVE RELIABILITY, FUNCTION OR DESIGN. FAIRCHILD DOES NOT ASSUME ANY LIABILITY ARISING OUT OF THE APPLICATION OR USE OF ANY PRODUCT OR CIRCUIT DESCRIBED HEREIN; NEITHER DOES IT CONVEY ANY LICENSE UNDER ITS PATENT RIGHTS, NOR THE RIGHTS OF OTHERS.

LIFE SUPPORT POLICY

FAIRCHILD'S PRODUCTS ARE NOT AUTHORIZED FOR USE AS CRITICAL COMPONENTS IN LIFE SUPPORT DEVICES OR SYSTEMS WITHOUT THE EXPRESS WRITTEN APPROVAL OF FAIRCHILD SEMICONDUCTOR CORPORATION. As used herein:

1. Life support devices or systems are devices or systems which, (a) are intended for surgical implant into the body, or (b) support or sustain life, or (c) whose failure to perform when properly used in accordance with instructions for use provided in the labeling, can be reasonably expected to result in significant injury to the user.
2. A critical component is any component of a life support device or system whose failure to perform can be reasonably expected to cause the failure of the life support device or system, or to affect its safety or effectiveness.

PRODUCT STATUS DEFINITIONS

Definition of Terms

Datasheet Identification	Product Status	Definition
Advance Information	Formative or In Design	This datasheet contains the design specifications for product development. Specifications may change in any manner without notice.
Preliminary	First Production	This datasheet contains preliminary data, and supplementary data will be published at a later date. Fairchild Semiconductor reserves the right to make changes at any time without notice in order to improve design.
No Identification Needed	Full Production	This datasheet contains final specifications. Fairchild Semiconductor reserves the right to make changes at any time without notice in order to improve design.
Obsolete	Not In Production	This datasheet contains specifications on a product that has been discontinued by Fairchild semiconductor. The datasheet is printed for reference information only.

Rev. 118