



8-INPUT PRIORITY ENCODERS WITH 3-STATE OUTPUTS

The SN54/74LS348 and the SN54/74LS848 are eight input priority encoders which provide the 8-line to 3-line function.

The outputs (A0–A2) and inputs (0–7) are active low. The active low input which has the highest priority (input 7 has the highest) is represented on the outputs (output A0 is the lowest bit). An example would be if inputs 1, 2 and 4 were low, then a binary 4 would be represented on the outputs.

The GS (Group Signal) output is active low when any of the inputs are low. It serves to indicate when any of the inputs are active.

A0, A1 and A2 are three-state outputs. This allows for up to 64 line expansion without the need for special external circuitry.

A logical one on the Enable Input (EI) forces A0, A1 and A2 to the disabled state and outputs GS and EO to the high state. A high on all data inputs (0–7) together with a low on the EI input disables outputs A0, A1, and A2 and forces output GS to the high state and output EO to the low state.

Use of the EI input in conjunction with the EO output provides for the capability of having priority encoding of n input signals.

The LS848 has special internal circuitry providing for a greatly reduced negative going glitch on the GS (Group Signal) output and on a reduced tendency for the A0, A1 and A2 outputs to become momentarily enabled. Both of these occurrences happen when the EI input goes from a logical one to a logical zero and all data inputs (0–7) are held at logical ones. The internal glitch reduction circuitry does add an additional fan-in of one on all data inputs (compared to that of the LS348).

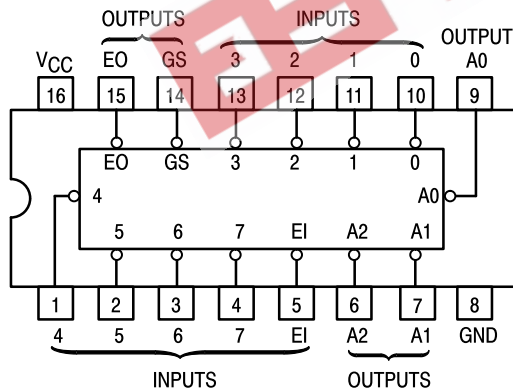

FUNCTION TABLE

EI	INPUTS								OUTPUTS				
	0	1	2	3	4	5	6	7	A2	A1	A0	GS	EO
H	X	X	X	X	X	X	X	X	Z	Z	Z	H	H
L	H	H	H	H	H	H	H	H	Z	Z	Z	H	L
L	X	X	X	X	X	X	X	L	L	L	L	L	H
L	X	X	X	X	X	L	H	H	L	H	L	L	H
L	X	X	X	X	L	H	H	H	L	H	L	L	H
L	X	X	X	L	H	H	H	H	H	L	L	L	H
L	X	X	L	H	H	H	H	H	H	L	L	L	H
L	X	L	H	H	H	H	H	H	H	H	L	L	H
L	L	H	H	H	H	H	H	H	H	H	H	L	H

H = HIGH Logic Level
 L = LOW Logic Level
 X = Irrelevant
 Z = High Impedance State

SN54/74LS348
SN54/74LS848

8-INPUT PRIORITY ENCODERS WITH 3-STATE OUTPUTS

LOW POWER SCHOTTKY

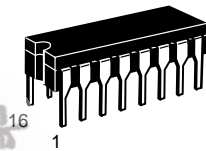

J SUFFIX
 CERAMIC
 CASE 620-09

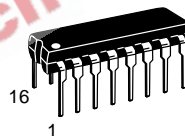

N SUFFIX
 PLASTIC
 CASE 648-08

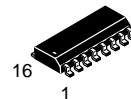

D SUFFIX
 SOIC
 CASE 751B-03

ORDERING INFORMATION

- SN54LSXXXJ Ceramic
- SN74LSXXXN Plastic
- SN74LSXXXD SOIC

SN54/74LS348 • SN54/74LS848

BLOCK DIAGRAMS

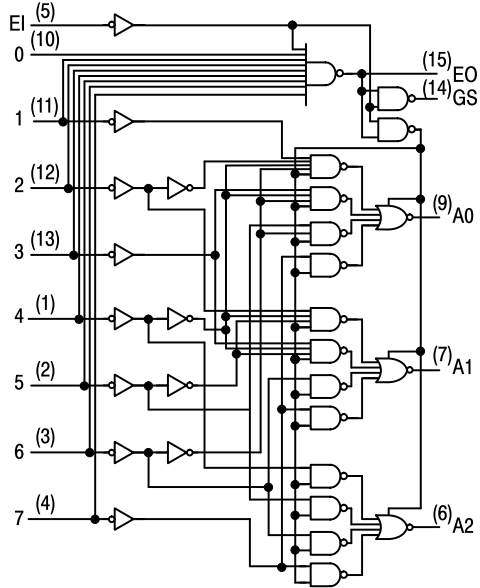

SN54/74LS348

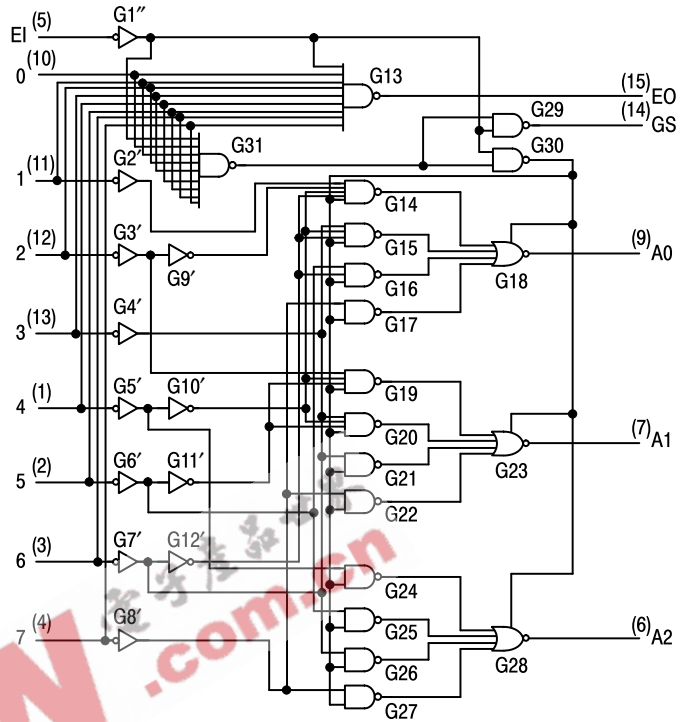

SN54/74LS848

GUARANTEED OPERATING RANGES

Symbol	Parameter		Min	Typ	Max	Unit
V _{CC}	Supply Voltage	54	4.5	5.0	5.5	V
		74	4.75	5.0	5.25	
T _A	Operating Ambient Temperature Range	54	-55	25	125	°C
		74	0	25	70	
I _{OH}	Output Current — High	EO, GS	54, 74		-0.4	mA
I _{OH}	Output Current — High	A0, A1, A2	54		-1.0	mA
		A0, A1, A2	74		-2.6	
I _{OL}	Output Current — Low	EO, GS	54		4.0	mA
		74		8.0		
I _{OL}	Output Current — Low	A0, A1, A2	54		12	mA
		74		24		

SN54/74LS348 • SN54/74LS848

DC CHARACTERISTICS OVER OPERATING TEMPERATURE RANGE (unless otherwise specified)

Symbol	Parameter	Limits			Unit	Test Conditions	
		Min	Typ	Max			
V _{IH}	Input HIGH Voltage	2.0			V	Guaranteed Input HIGH Voltage for All Inputs	
V _{IL}	Input LOW Voltage	54		0.7	V	Guaranteed Input LOW Voltage for All Inputs	
		74		0.8			
V _{IK}	Input Clamp Diode Voltage		-0.65	-1.5	V	V _{CC} = MIN, I _{IN} = -18 mA	
V _{OH}	Output HIGH Voltage A0, A1, A2	54, 74	2.4	3.1	V	V _{CC} = MIN, I _{OH} = MAX, V _{IN} = V _{IH} or V _{IL} per Truth Table	
	EO, GS	54	2.5	3.5	V		
	EO, GS	74	2.7	3.5	V		
V _{OL}	Output LOW Voltage EO, GS	54, 74		0.25	0.4	V	I _{OL} = 4.0 mA V _{CC} = V _{CC} MIN, V _{IN} = V _{IL} or V _{IH} per Truth Table
		74		0.35	0.5	V	
V _{OL}	Output LOW Voltage A0, A1, A2	54, 74		0.25	0.4	V	V _{CC} = V _{CC} MIN, V _{IN} = V _{IL} or V _{IH} per Truth Table
		74		0.35	0.5	V	
I _{OZH}	Output Off Current HIGH			20	μA	V _{CC} = MAX, V _{OUT} = 2.7 V	
I _{OZL}	Output Off Current LOW			-20	μA	V _{CC} = MAX, V _{OUT} = 0.4 V	
I _{IH}	Input HIGH Current Input 0, EI — LS348 Input 0 — LS848 Other — LS348 Other — LS848			20	μA	V _{CC} = MAX, V _{IN} = 2.7 V	
				40	μA		
				40	μA		
				60	μA		
	Input HIGH Current Input 0, EI — LS348 Input 0 — LS848 Other — LS348 Other — LS848			0.1	mA	V _{CC} = MAX, V _{IN} = 7.0 V	
				0.2	mA		
			0.2 0.3	mA mA			
I _{IL}	Input LOW Current Input 0, EI — LS348 Input 0 — LS848 Other — LS348 Other — LS848			-0.4	mA	V _{CC} = MAX, V _{IN} = 0.4 V	
				-0.8	mA		
				-0.8	mA		
				-1.2	mA		
I _{OS}	Short Circuit Current (Note 1) EO, GS A0, A1, A2	-20		-120	mA	V _{CC} = MAX	
		-30		-130	mA		
I _{CC}	Power Supply Current Total, Output HIGH		12	23	mA	V _{CC} = MAX All Inputs and Outputs Open	
	Total, Output LOW		13	25		V _{CC} = MAX, Inputs 7, EI = GND All Others Open	

Note 1: Not more than one output should be shorted at a time, nor for more than 1 second.

SN54/74LS348 • SN54/74LS848

AC CHARACTERISTICS ($V_{CC} = 5.0\text{ V}$, $T_A = 25^\circ\text{C}$)

Symbol	From (Input)	To (Output)	Waveform	LS348 Limits			LS848 Limits			Unit	Test Conditions
				Min	Typ	Max	Min	Typ	Max		
t _{PLH}	1 thru 7	A0, A1 or A2	In-Phase output		11	17		12	18	ns	C _L = 45 pF R _L = 667 Ω
t _{PHL}					20	30		20	30		
t _{PLH}	1 thru 7	A0, A1 or A2	Out-of-Phase output		23	35		23	35	ns	
t _{PHL}					23	35		23	35		
t _{PZH}	EI	A0, A1 or A2			25	39		25	39	ns	
t _{PZL}					24	41		24	41		
t _{PLH}	0 thru 7	E0	Out-of-Phase output		11	18		11	18	ns	
t _{PHL}					26	40		26	40		
t _{PLH}	0 thru 7	GS	In-Phase output		38	55		38	55	ns	
t _{PHL}					9.0	21		9.0	21		
t _{PLH}	EI	GS	In-Phase output		11	17		11	17	ns	
t _{PHL}					14	36		14	36		
t _{PLH}	EI	EO	In-Phase output		17	21		17	21	ns	
t _{PHL}					25	40		30	45		
t _{PHZ}	EI	A0, A1 or A2			18	27		18	27	ns	
t _{PLZ}					23	35		23	35		

**Case 751B-03 D Suffix
16-Pin Plastic
SO-16**

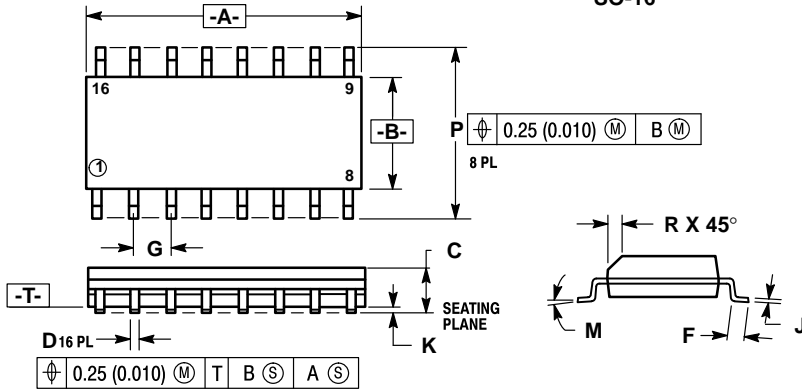

NOTES:

1. DIMENSIONING AND TOLERANCING PER ANSI Y14.5M, 1982.
2. CONTROLLING DIMENSION: MILLIMETER.
3. DIMENSION A AND B DO NOT INCLUDE MOLD PROTRUSION.
4. MAXIMUM MOLD PROTRUSION 0.15 (0.006) PER SIDE.
5. 751B-01 IS OBSOLETE, NEW STANDARD 751B-03.

DIM	MILLIMETERS		INCHES	
	MIN	MAX	MIN	MAX
A	9.80	10.00	0.386	0.393
B	3.80	4.00	0.150	0.157
C	1.35	1.75	0.054	0.068
D	0.35	0.49	0.014	0.019
F	0.40	1.25	0.016	0.049
G	1.27 BSC		0.050 BSC	
J	0.19	0.25	0.008	0.009
K	0.10	0.25	0.004	0.009
M	0°	7°	0°	7°
P	5.80	6.20	0.229	0.244
R	0.25	0.50	0.010	0.019

**Case 648-08 N Suffix
16-Pin Plastic**

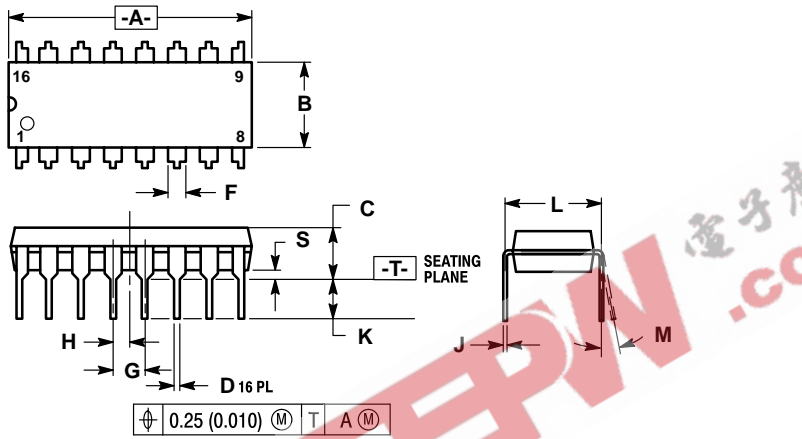

NOTES:

1. DIMENSIONING AND TOLERANCING PER ANSI Y14.5M, 1982.
2. CONTROLLING DIMENSION: INCH.
3. DIMENSION "L" TO CENTER OF LEADS WHEN FORMED PARALLEL.
4. DIMENSION "B" DOES NOT INCLUDE MOLD FLASH.
5. ROUNDED CORNERS OPTIONAL.
6. 648-01 THRU -07 OBSOLETE, NEW STANDARD 648-08.

DIM	MILLIMETERS		INCHES	
	MIN	MAX	MIN	MAX
A	18.80	19.55	0.740	0.770
B	6.35	6.85	0.250	0.270
C	3.69	4.44	0.145	0.175
D	0.39	0.53	0.015	0.021
F	1.02	1.77	0.040	0.070
G	2.54 BSC		0.100 BSC	
H	1.27 BSC		0.050 BSC	
J	0.21	0.38	0.008	0.015
K	2.80	3.30	0.110	0.130
L	7.50	7.74	0.295	0.305
M	0°	10°	0°	10°
S	0.51	1.01	0.020	0.040

**Case 620-09 J Suffix
16-Pin Ceramic Dual In-Line**

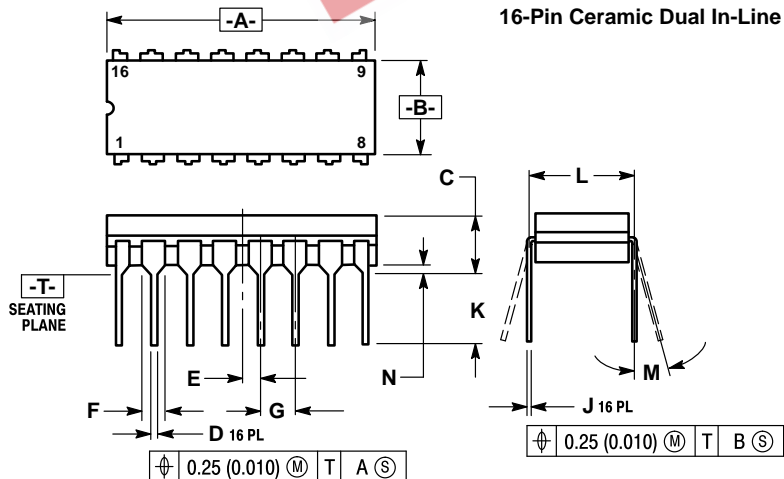

NOTES:

1. DIMENSIONING AND TOLERANCING PER ANSI Y14.5M, 1982.
2. CONTROLLING DIMENSION: INCH.
3. DIMENSION L TO CENTER OF LEAD WHEN FORMED PARALLEL.
4. DIM F MAY NARROW TO 0.76 (0.030) WHERE THE LEAD ENTERS THE CERAMIC BODY.
5. 620-01 THRU -08 OBSOLETE, NEW STANDARD 620-09.

DIM	MILLIMETERS		INCHES	
	MIN	MAX	MIN	MAX
A	19.05	19.55	0.750	0.770
B	6.10	7.36	0.240	0.290
C	—	4.19	—	0.165
D	0.39	0.53	0.015	0.021
E	1.27 BSC		0.050 BSC	
F	1.40	1.77	0.055	0.070
G	2.54 BSC		0.100 BSC	
J	0.23	0.27	0.009	0.011
K	—	5.08	—	0.200
L	7.62 BSC		0.300 BSC	
M	0°	15°	0°	15°
N	0.39	0.88	0.015	0.035

EETW 电子產品世界
.com.cn

Motorola reserves the right to make changes without further notice to any products herein. Motorola makes no warranty, representation or guarantee regarding the suitability of its products for any particular purpose, nor does Motorola assume any liability arising out of the application or use of any product or circuit, and specifically disclaims any and all liability, including without limitation consequential or incidental damages. "Typical" parameters can and do vary in different applications. All operating parameters, including "Typicals" must be validated for each customer application by customer's technical experts. Motorola does not convey any license under its patent rights nor the rights of others. Motorola products are not designed, intended, or authorized for use as components in systems intended for surgical implant into the body, or other applications intended to support or sustain life, or for any other application in which the failure of the Motorola product could create a situation where personal injury or death may occur. Should Buyer purchase or use Motorola products for any such unintended or unauthorized application, Buyer shall indemnify and hold Motorola and its officers, employees, subsidiaries, affiliates, and distributors harmless against all claims, costs, damages, and expenses, and reasonable attorney fees arising out of, directly or indirectly, any claim of personal injury or death associated with such unintended or unauthorized use, even if such claim alleges that Motorola was negligent regarding the design or manufacture of the part. Motorola and  are registered trademarks of Motorola, Inc. Motorola, Inc. is an Equal Opportunity/Affirmative Action Employer.

Literature Distribution Centers:

USA: Motorola Literature Distribution; P.O. Box 20912; Phoenix, Arizona 85036.

EUROPE: Motorola Ltd.; European Literature Centre; 88 Tanners Drive, Blakelands, Milton Keynes, MK14 5BP, England.

JAPAN: Nippon Motorola Ltd.; 4-32-1, Nishi-Gotanda, Shinagawa-ku, Tokyo 141, Japan.

ASIA PACIFIC: Motorola Semiconductors H.K. Ltd.; Silicon Harbour Center, No. 2 Dai King Street, Tai Po Industrial Estate, Tai Po, N.T., Hong Kong.

