

DATA SHEET

EEPW 电子产品世界
.com.cn

74F579

8-bit bidirectional binary counter (3-State)

Product specification

1992 May 04

IC15 Data Handbook

8-bit bidirectional binary counter (3-State)

74F579

FEATURES

- Fully synchronous operation
- Multiplexed 3-State I/O ports for bus oriented applications
- Built in cascading carry capability
- U/ \bar{D} pin to control direction of counting
- Separate pins for Master reset and Synchronous operation
- Center power pins to reduce effects of package inductance
- Count frequency 115MHz Typ
- Supply current 100mA Typ
- See 74F269 for 24-pin separate I/O port version
- See 74F779 for 16-pin version

DESCRIPTION

The 74F579 is a fully synchronous 8-stage Up/Down Counter with multiplexed 3-State I/O ports for bus-oriented applications. It features a preset capability for programmable operation, carry look-ahead for easy cascading and a U/ \bar{D} input to control the direction of counting. All state changes, except for the case of asynchronous reset, are initiated by the rising edge of the clock. $\bar{T}C$ output is not recommended for use as a clock or asynchronous reset due to the possibility of decoding spikes.

PIN CONFIGURATION

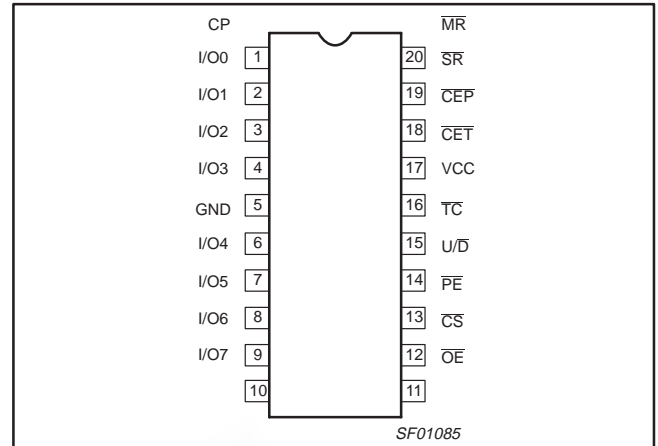

ORDERING INFORMATION

TYPE	TYPICAL f_{MAX}	TYPICAL SUPPLY CURRENT (TOTAL)
74F579	115MHz	100mA

ORDERING INFORMATION

DESCRIPTION	COMMERCIAL RANGE $V_{CC} = 5V \pm 10\%$, $T_{amb} = 0^{\circ}C$ to $+70^{\circ}C$	PKG DWG #
20-Pin Plastic DIP	N74F579N	SOT146-1
20-Pin Plastic SOL	N74F579D	SOT163-1

INPUT AND OUTPUT LOADING AND FAN-OUT TABLE

PINS	DESCRIPTION	74F(U.L.) HIGH/LOW	LOAD VALUE HIGH/LOW
I/O _n	Data Inputs	3.5/1.0	70 μ A/0.6mA
	Data Outputs	150/40	3.0mA/24mA
PE	Parallel Enable input (active Low)	1.0/1.0	20 μ A/0.6mA
U/ \bar{D}	Up/Down count control input	1.0/1.0	20 μ A/0.6mA
$\bar{M}R$	Master Reset input (active Low)	1.0/1.0	20 μ A/0.6mA
$\bar{S}R$	Synchronous Reset input (active Low)	1.0/1.0	20 μ A/0.6mA
$\bar{C}E\bar{P}$	Count Enable Parallel input (active Low)	1.0/1.0	20 μ A/0.6mA
$\bar{C}E\bar{T}$	Count Enable Trickle input (active Low)	1.0/1.0	20 μ A/0.6mA
$\bar{C}S$	Chip Select input (active Low)	1.0/1.0	20 μ A/0.6mA
$\bar{O}E$	Output Enable input (active Low)	1.0/1.0	20 μ A/0.6mA
CP	Clock input (active Rising Edge)	1.0/1.0	20 μ A/0.6mA
$\bar{T}C$	Terminal Count Output (active Low)	50/33	1.0mA/20mA

NOTE: One (1.0) FAST Unit Load (U.L.) is defined as: 20 μ A in the High state and 0.6mA in the Low state.

8-bit bidirectional binary counter (3-State)

74F579

LOGIC SYMBOL

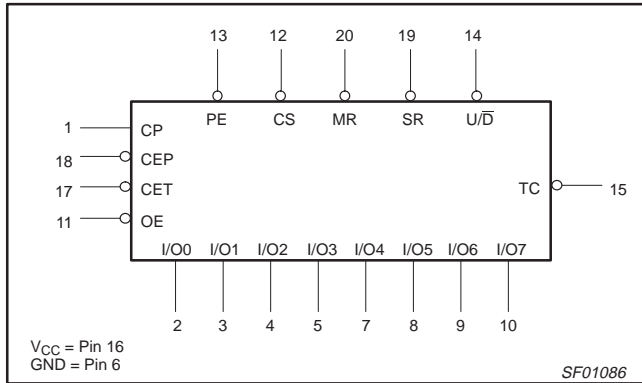

LOGIC SYMBOL (IEEE/IEC)

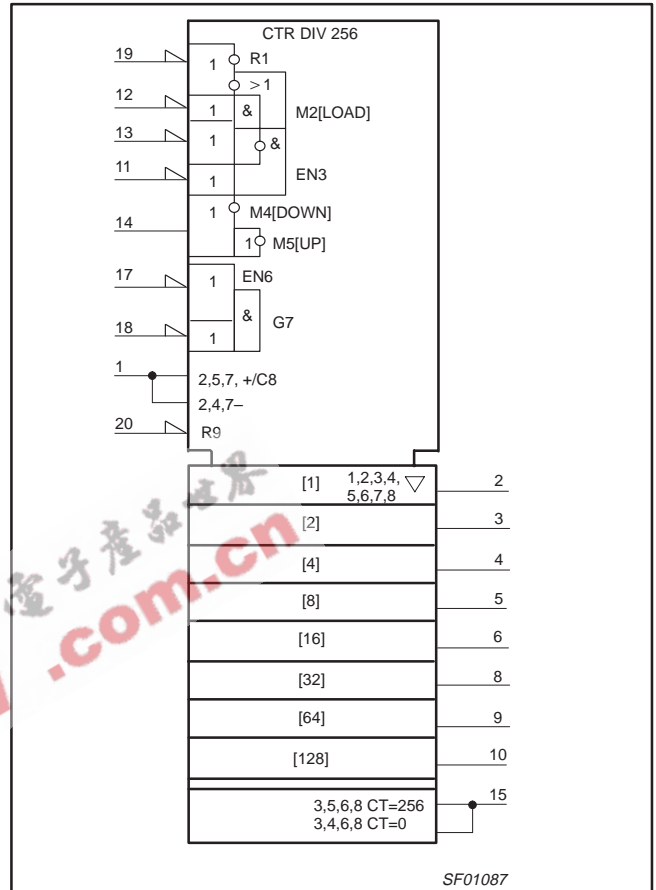

FUNCTION TABLE

INPUTS									OPERATING MODE
MR	SR	CS	PE	CEP	CET	U/D	OE	CP	
X	X	H	X	X	X	X	X	X	I/O0 to I/O7 in high impedance (PE disabled)
X	X	L	H	X	X	X	H	X	I/O0 to I/O7 in high impedance
X	X	L	H	X	X	X	L	X	Flip-flop output appears on I/O _n lines
L	X	X	X	X	X	X	X	X	Asynchronous reset for all flip-flops
H	L	X	X	X	X	X	X	↑	Synchronous reset for all flip-flops
H	H	L	L	X	X	X	X	↑	Parallel load all flip-flops
H	H	(not LL)		H	X	X	X	↑	Hold
H	H	(not LL)		X	H	X	X	↑	Hold (TC held High)
H	H	(not LL)		L	L	H	X	↑	Count up
H	H	(not LL)		L	L	L	X	↑	Count down

- H = High voltage level
- L = Low voltage level
- X = Don't care
- ↑ = Low-to-High clock transition
- (not LL) = CS and PE should never be Low voltage level at the same time.

8-bit bidirectional binary counter (3-State)

74F579

LOGIC DIAGRAM

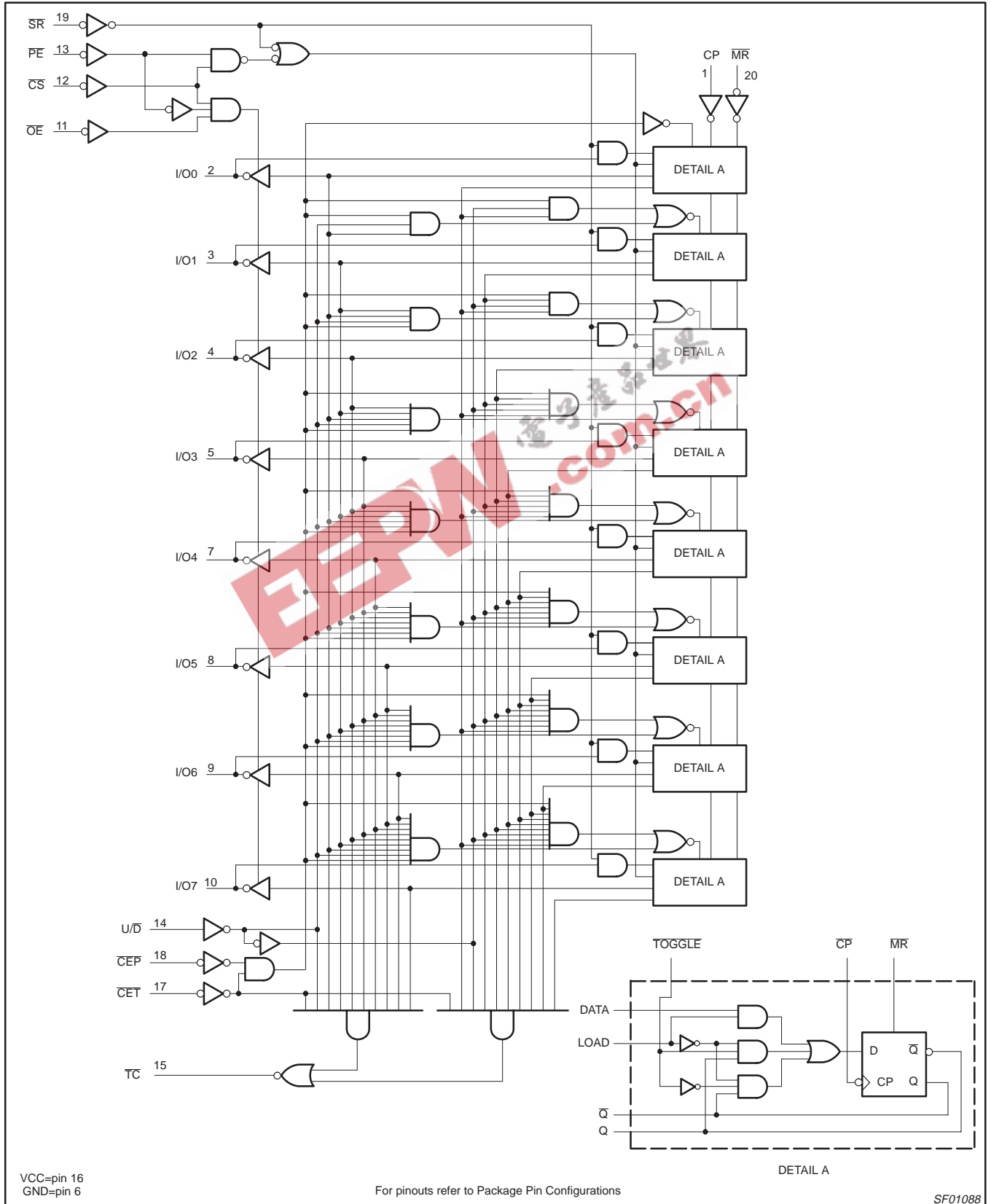

8-bit bidirectional binary counter (3-State)

74F579

ABSOLUTE MAXIMUM RATINGS

(Operation beyond the limits set forth in this table may impair the useful life of the device.
Unless otherwise noted these limits are over the operating free-air temperature range.)

SYMBOL	PARAMETER	RATING	UNIT	
V_{CC}	Supply voltage	-0.5 to +7.0	V	
V_{IN}	Input voltage	-0.5 to +7.0	V	
I_{IN}	Input current	-30 to +5	mA	
V_O	Voltage applied to output in High output state	-0.5 to $+V_{CC}$	V	
I_O	Current applied to output in Low output state	\overline{TC}	40	mA
		I/O0	48	mA
T_{amb}	Operating free-air temperature range	0 to +70	°C	
T_{stg}	Storage temperature	-65 to +150	°C	

RECOMMENDED OPERATING CONDITIONS

SYMBOL	PARAMETER	LIMITS			UNIT
		MIN	NOM	MAX	
V_{CC}	Supply voltage	4.5	5.0	5.5	V
V_{IH}	High-level input voltage	2.0			V
V_{IL}	Low-level input voltage			0.8	V
I_{IK}	Input clamp current			-18	mA
I_{OH}	High-level output current	\overline{TC}		-1	mA
		I/O _n		-3	mA
I_{OL}	Low-level output current	\overline{TC}		20	mA
		I/O _n		24	mA
T_{amb}	Operating free-air temperature range	0		70	°C

8-bit bidirectional binary counter (3-State)

74F579

DC ELECTRICAL CHARACTERISTICS

(Over recommended operating free-air temperature range unless otherwise noted.)

SYMBOL	PARAMETER		TEST CONDITIONS ¹			LIMITS			UNIT
						MIN	TYP ²	MAX	
V _{OH}	High-level output voltage	\overline{TC}	V _{CC} = MIN, V _{IL} = MAX, V _{IH} = MIN (V _{IL} = 0.0V, V _{IH} = 4.5V for MR, CP inputs)	I _{OH} = -1mA	±10%V _{CC}	2.5			V
					±5%V _{CC}	2.7	3.4		V
		I/O _n		I _{OH} = -3mA	±10%V _{CC}	2.4	3.3		V
					±5%V _{CC}	2.7	3.3		V
V _{OL}	Low-level output voltage		V _{CC} = MIN, V _{IL} = MAX, V _{IH} = MIN	I _{OL} = MAX,	±10%V _{CC}		0.35	0.50	V
					±5%V _{CC}		0.35	0.50	V
V _{IK}	Input clamp voltage		V _{CC} = MIN, I _I = I _{IK}				-0.73	-1.2	V
I _I	Input current at maximum input voltage	I/O _n	V _{CC} = MAX, V _I = 5.5V					1	mA
		others	V _{CC} = MAX, V _I = 7.0V					100	μA
I _{IH}	High-level input current	except I/O _n	V _{CC} = MAX, V _I = 2.7V					20	μA
I _{IL}	Low-level input current	I/O _n	V _{CC} = MAX, V _I = 0.5V					-0.6	mA
I _{OZH} + I _{IH}	Off-state output current High-level voltage applied	I/O _n	V _{CC} = MAX, V _O = 2.7V					70	μA
			V _{CC} = MAX, V _O = 0.5V					-600	μA
I _{OZL} + I _{IL}	Off-state output current Low-level voltage applied								
I _{OS}	Short-circuit output current ³		V _{CC} = MAX			-60		-150	mA
I _{CC}	Supply current (total)	I _{CCH}	V _{CC} = MAX				95	135	mA
		I _{CCL}					105	145	mA
		I _{CCZ}					105	150	mA

NOTES:

- For conditions shown as MIN or MAX, use the appropriate value specified under Recommended Operating Conditions for the applicable type.
- All typical values are at V_{CC} = 5V, T_{amb} = 25°C.
- Not more than one output should be shorted at a time. For testing I_{OS}, the use of high-speed test apparatus and/or sample-and-hold techniques are preferable in order to minimize internal heating and more accurately reflect operational values. Otherwise, prolonged shorting of a High output may raise the chip temperature well above normal and thereby cause invalid readings in other parameter tests. In any sequence of parameter test, I_{OS} tests should be performed last.

8-bit bidirectional binary counter (3-State)

74F579

AC ELECTRICAL CHARACTERISTICS

SYMBOL	PARAMETER	TEST CONDITIONS	LIMITS					UNIT
			T _{amb} = +25°C V _{CC} = +5.0V C _L = 50pF, R _L = 500Ω			T _{amb} = 0°C to +70°C V _{CC} = +5.0V ± 10% C _L = 50pF, R _L = 500Ω		
			MIN	TYP	MAX	MIN	MAX	
f _{MAX}	Maximum clock frequency	Waveform 1	100	115		80		MHz
t _{PLH} t _{PHL}	Propagation delay CP to I/O _n	Waveform 1	5.0 5.0	7.5 7.5	10.5 10.5	4.5 5.0	11.5 11.5	ns ns
t _{PLH} t _{PHL}	Propagation delay CP to TC	Waveform 1	5.5 5.5	7.5 7.5	10.0 10.0	5.0 5.0	11.0 11.0	ns ns
t _{PLH} t _{PHL}	Propagation delay U/D to TC	Waveform 4	3.5 4.5	5.5 6.5	8.0 8.0	3.5 4.5	9.0 9.0	ns ns
t _{PLH} t _{PHL}	Propagation delay CET to TC	Waveform 3	3.5 3.5	5.5 6.0	7.0 8.0	3.5 3.5	8.5 8.5	ns ns
t _{PHL}	Propagation delay MR to I/O _n	Waveform 2	5.0	7.0	9.0	5.0	10.0	ns
t _{PLH} t _{PHL}	Propagation delay MR to TC	Waveform 4	4.0 6.0	6.5 8.0	9.0 10.5	4.0 6.0	10.5 12.5	ns ns
t _{PZH} t _{PZL}	Output Enable time CS to I/O _n	Waveform 6 Waveform 7	4.0 5.5	5.0 7.0	8.5 10.5	3.5 5.0	10.0 11.5	ns ns
t _{PHZ} t _{PLZ}	Output Disable time CS to I/O _n	Waveform 6 Waveform 7	3.0 5.0	5.0 7.5	7.5 9.5	3.0 4.5	9.0 11.0	ns ns
t _{PZH} t _{PZL}	Output Enable time PE to I/O _n	Waveform 6 Waveform 7	3.0 5.0	4.5 6.5	8.0 10.0	3.0 4.5	9.0 11.0	ns ns
t _{PHZ} t _{PLZ}	Output Disable time PE to I/O _n	Waveform 6 Waveform 7	3.0 2.5	4.0 4.0	7.5 7.5	3.0 2.0	9.0 8.5	ns ns
t _{PZH} t _{PZL}	Output Enable time OE to I/O _n	Waveform 6 Waveform 7	2.5 4.5	4.0 5.5	7.0 9.0	2.5 4.0	8.5 10.5	ns ns
t _{PHZ} t _{PLZ}	Output Enable time OE to I/O _n	Waveform 6 Waveform 7	1.0 2.0	2.5 4.0	4.0 7.0	1.0 2.0	5.5 8.0	ns ns

8-bit bidirectional binary counter (3-State)

74F579

AC SETUP REQUIREMENTS

SYMBOL	PARAMETER	TEST CONDITIONS	LIMITS					UNIT
			T _{amb} = +25°C V _{CC} = +5.0V C _L = 50pF, R _L = 500Ω			T _{amb} = 0°C to +70°C V _{CC} = +5.0V ± 10% C _L = 50pF, R _L = 500Ω		
			MIN	TYP	MAX	MIN	MAX	
t _s (H) t _s (L)	Setup time, High or Low I/O _n to CP	Waveform 5	3.0 3.0			4.0 4.0		ns ns
t _h (H) t _h (L)	Hold time, High or Low I/O _n to CP	Waveform 5	0 0			0 0		ns ns
t _s (H) t _s (L)	Setup time, High or Low U/D to CP	Waveform 5	8.0 8.0			9.0 9.0		ns ns
t _h (H) t _h (L)	Hold time, High or Low U/D to CP	Waveform 5	0 0			0 0		ns ns
t _s (H) t _s (L)	Setup time, High or Low PE, SR or CS to CP	Waveform 5	9.5 9.5			10.0 10.0		ns ns
t _h (H) t _h (L)	Hold time, High or Low PE, SR or CS to CP	Waveform 5	0 0			0 0		ns ns
t _s (H) t _s (L)	Setup time, High or Low CEP or CET to CP	Waveform 5	5.0 9.0			5.5 10.5		ns ns
t _h (H) t _h (L)	Hold time, High or Low CEP or CET to CP	Waveform 5	0 0			0 0		ns ns
t _w (H) t _w (L)	CP Pulse width, High or Low	Waveform 1	4.5 4.5			4.5 4.5		ns ns
t _w (L)	MR Pulse width, Low	Waveform 2	3.0			3.0		ns
t _{rec}	Recovery time, MR to CP	Waveform 2	4.0			4.5		ns

8-bit bidirectional binary counter (3-State)

74F579

AC WAVEFORMS

NOTE: For all waveforms $V_M = 1.5V$.

The shaded areas indicate when the input is permitted to change for predictable output performance.

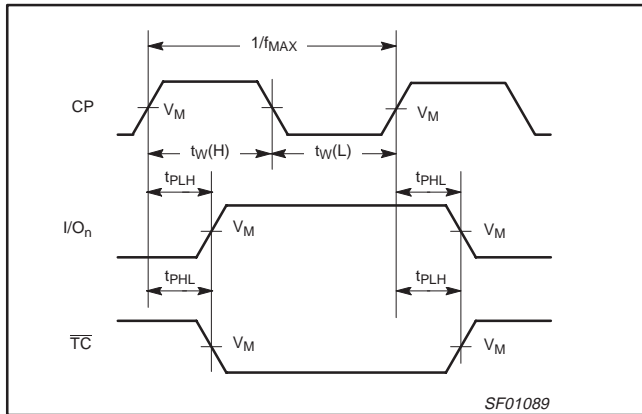

Waveform 1. Propagation Delay, Clock Input to Output, Clock Pulse Width and Maximum Clock Frequency

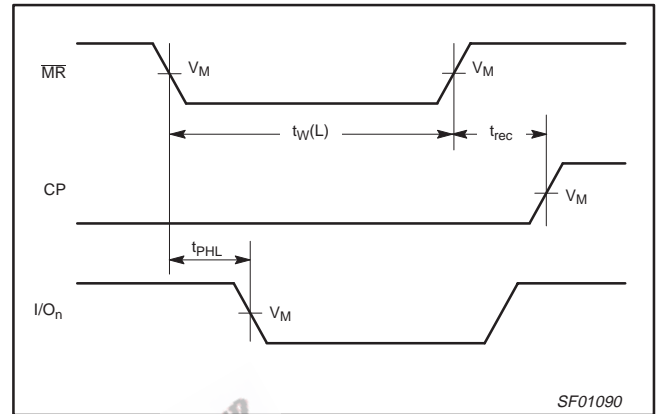

Waveform 2. Master Reset Pulse Width, Master Reset to Output Delay and Master Reset to Clock Recovery Time

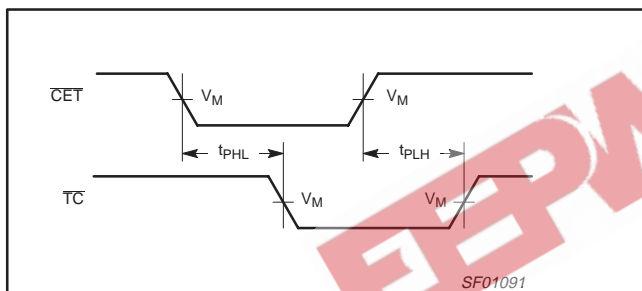

Waveform 3. Propagation Delay, CET Input to Terminal Count Output

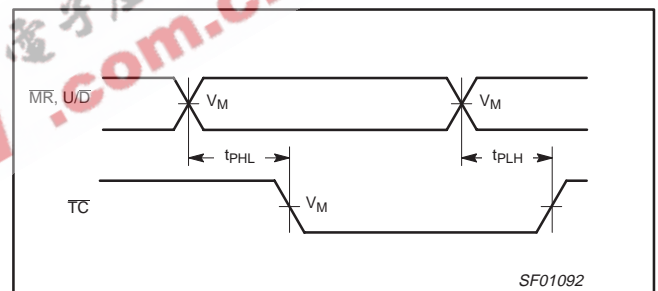

Waveform 4. Propagation Delay, U/D and MR Inputs to Terminal Count Output

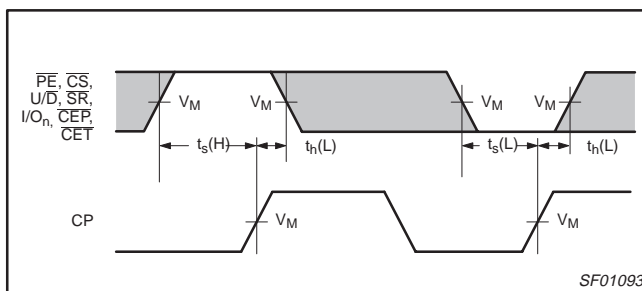

Waveform 5. Setup and Hold Times

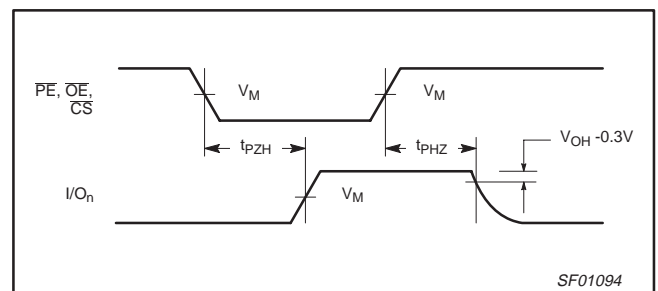

Waveform 6. 3-State Output Enable Time to High Level and Output Disable Time from High Level

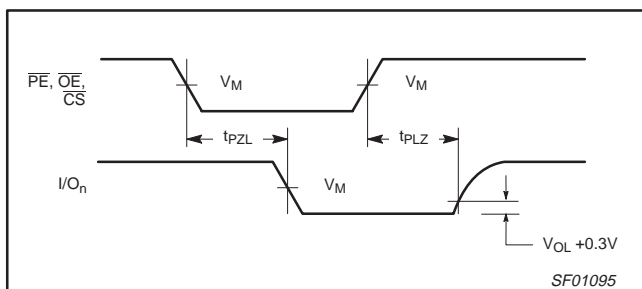

Waveform 7. 3-State Output Enable Time to Low Level and Output Disable Time from Low Level

8-bit bidirectional binary counter (3-State)

74F579

TEST CIRCUIT AND WAVEFORMS

Test Circuit for 3-State Outputs

Input Pulse Definition

SWITCH POSITION

TEST	SWITCH
t_{PLZ}	closed
t_{PZL}	closed
All other	open

DEFINITIONS:

R_L = Load resistor; see AC electrical characteristics for value.

C_L = Load capacitance includes jig and probe capacitance; see AC electrical characteristics for value.

R_T = Termination resistance should be equal to Z_{OUT} of pulse generators.

family	INPUT PULSE REQUIREMENTS					
	amplitude V_M	rep. rate	t_w	t_{TLH}	t_{THL}	
74F	3.0V	1MHz	500ns	2.5ns	2.5ns	

SF00777

8-bit bidirectional binary counter (3-State)

74F579

DIP20: plastic dual in-line package; 20 leads (300 mil)

SOT146-1

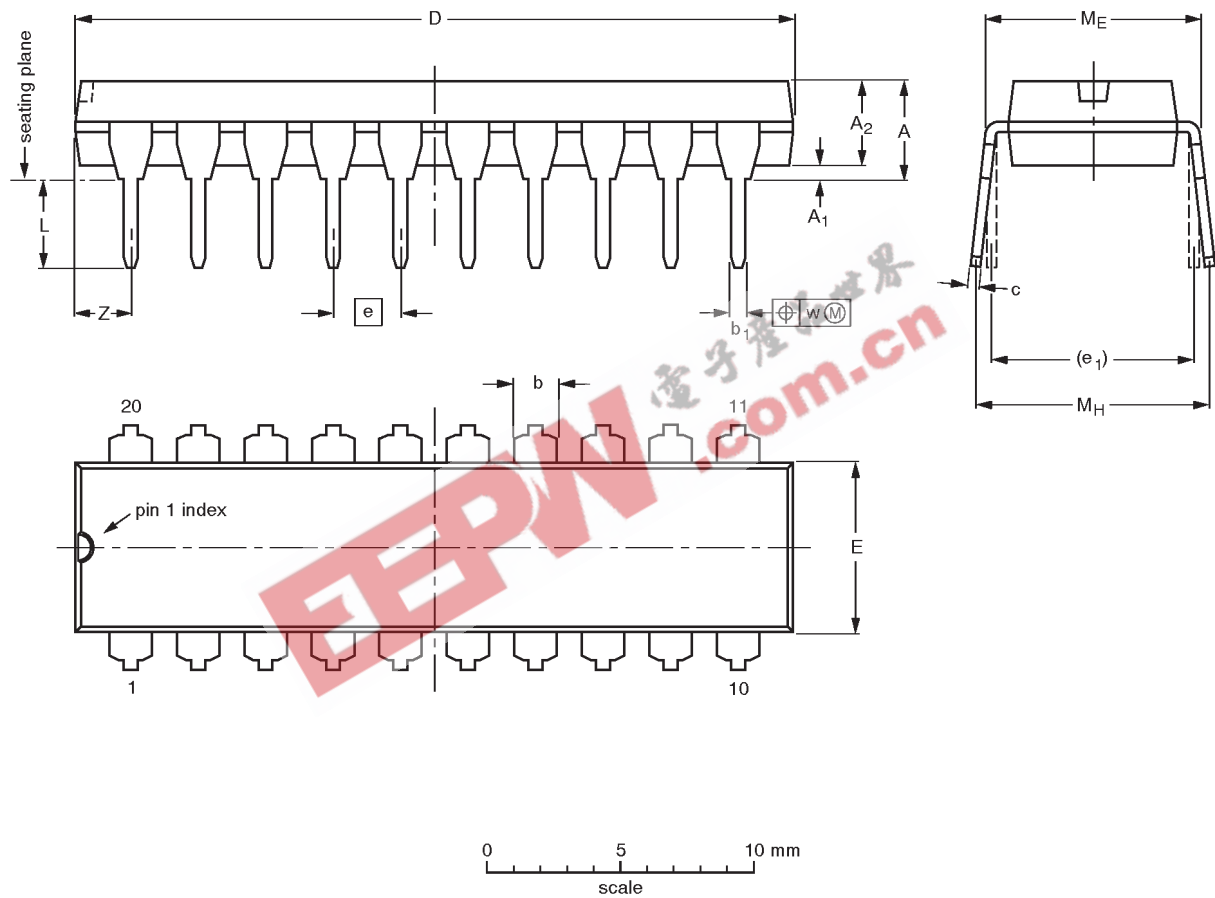

DIMENSIONS (inch dimensions are derived from the original mm dimensions)

UNIT	A max.	A ₁ min.	A ₂ max.	b	b ₁	c	D ⁽¹⁾	E ⁽¹⁾	e	e ₁	L	M _E	M _H	w	Z ⁽¹⁾ max.
mm	4.2	0.51	3.2	1.73 1.30	0.53 0.38	0.36 0.23	26.92 26.54	6.40 6.22	2.54	7.62	3.60 3.05	8.25 7.80	10.0 8.3	0.254	2.0
inches	0.17	0.020	0.13	0.068 0.051	0.021 0.015	0.014 0.009	1.060 1.045	0.25 0.24	0.10	0.30	0.14 0.12	0.32 0.31	0.39 0.33	0.01	0.078

Note

1. Plastic or metal protrusions of 0.25 mm maximum per side are not included.

OUTLINE VERSION	REFERENCES				EUROPEAN PROJECTION	ISSUE DATE
	IEC	JEDEC	EIAJ			
SOT146-1			SC603			92-11-17 95-05-24

8-bit bidirectional binary counter (3-State)

74F579

SO20: plastic small outline package; 20 leads; body width 7.5 mm

SOT163-1

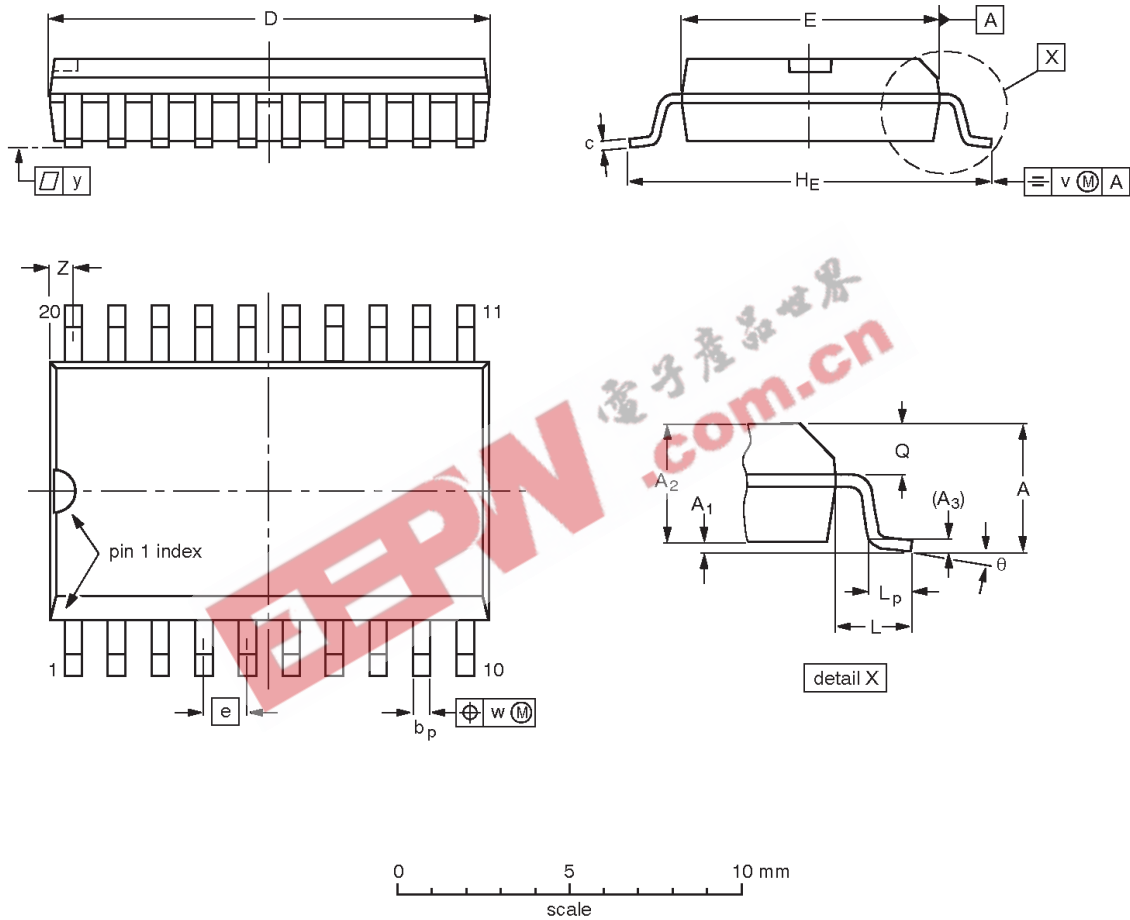

DIMENSIONS (inch dimensions are derived from the original mm dimensions)

UNIT	A max.	A ₁	A ₂	A ₃	b _p	c	D ⁽¹⁾	E ⁽¹⁾	e	H _E	L	L _p	Q	v	w	y	Z ⁽¹⁾	θ
mm	2.65	0.30 0.10	2.45 2.25	0.25	0.49 0.36	0.32 0.23	13.0 12.6	7.6 7.4	1.27	10.65 10.00	1.4	1.1 0.4	1.1 1.0	0.25	0.25	0.1	0.9 0.4	8° 0°
inches	0.10	0.012 0.004	0.096 0.089	0.01	0.019 0.014	0.013 0.009	0.51 0.49	0.30 0.29	0.050	0.419 0.394	0.055	0.043 0.016	0.043 0.039	0.01	0.01	0.004	0.035 0.016	

Note

1. Plastic or metal protrusions of 0.15 mm maximum per side are not included.

OUTLINE VERSION	REFERENCES				EUROPEAN PROJECTION	ISSUE DATE
	IEC	JEDEC	EIAJ			
SOT163-1	075E04	MS-013AC				95-01-24 97-05-22

8-bit bidirectional binary counter (3-State)

74F579

NOTES



8-bit bidirectional binary counter (3-State)

74F579

Data sheet status

Data sheet status	Product status	Definition [1]
Objective specification	Development	This data sheet contains the design target or goal specifications for product development. Specification may change in any manner without notice.
Preliminary specification	Qualification	This data sheet contains preliminary data, and supplementary data will be published at a later date. Philips Semiconductors reserves the right to make changes at any time without notice in order to improve design and supply the best possible product.
Product specification	Production	This data sheet contains final specifications. Philips Semiconductors reserves the right to make changes at any time without notice in order to improve design and supply the best possible product.

[1] Please consult the most recently issued datasheet before initiating or completing a design.

Definitions

Short-form specification — The data in a short-form specification is extracted from a full data sheet with the same type number and title. For detailed information see the relevant data sheet or data handbook.

Limiting values definition — Limiting values given are in accordance with the Absolute Maximum Rating System (IEC 134). Stress above one or more of the limiting values may cause permanent damage to the device. These are stress ratings only and operation of the device at these or at any other conditions above those given in the Characteristics sections of the specification is not implied. Exposure to limiting values for extended periods may affect device reliability.

Application information — Applications that are described herein for any of these products are for illustrative purposes only. Philips Semiconductors make no representation or warranty that such applications will be suitable for the specified use without further testing or modification.

Disclaimers

Life support — These products are not designed for use in life support appliances, devices or systems where malfunction of these products can reasonably be expected to result in personal injury. Philips Semiconductors customers using or selling these products for use in such applications do so at their own risk and agree to fully indemnify Philips Semiconductors for any damages resulting from such application.

Right to make changes — Philips Semiconductors reserves the right to make changes, without notice, in the products, including circuits, standard cells, and/or software, described or contained herein in order to improve design and/or performance. Philips Semiconductors assumes no responsibility or liability for the use of any of these products, conveys no license or title under any patent, copyright, or mask work right to these products, and makes no representations or warranties that these products are free from patent, copyright, or mask work right infringement, unless otherwise specified.

Philips Semiconductors
811 East Arques Avenue
P.O. Box 3409
Sunnyvale, California 94088-3409
Telephone 800-234-7381

© Copyright Philips Electronics North America Corporation 1998
All rights reserved. Printed in U.S.A.

print code

Date of release: 10-98

Document order number:

9397-750-05142

Let's make things better.