

# DATA SHEET

EEPW 电子產品世界  
.com.cn

## **74ABT16260/74ABTH16260**

12-bit to 24-bit multiplexed D-type latches  
(3-State)

Product specification  
Supersedes data of 1996 Nov 20  
IC23 Data Handbook

1998 Feb 10

## 12-bit to 24-bit multiplexed D-type latches (3-State)

74ABT16260  
74ABTH16260

## FEATURES

- ESD protection exceeds 2000V per Mil-Std-883C, Method 3015; exceeds 200V using machine model (C = 200pF, R = 0).
- Latch-up performance exceeds 500mA per JEDEC Standard JESD-17.
- Distributed  $V_{CC}$  and GND pin configuration minimizes high-speed switching noise.
- Flow-through architecture optimizes PCB layout.
- High-drive outputs ( $-32\text{mA } I_{OH}$ ,  $64\text{mA } I_{OL}$ ).
- 74ABTH16260 incorporates bus-hold inputs which eliminate the need for external pull-up resistors.
- Package options:
  - 56-pin plastic Shrink Small-Outline Package (SSOP)
  - 56-pin plastic Thin Shrink Small-Outline Package (TSSOP)

## DESCRIPTION

The 74ABT16260/74ABTH16260 is a 12-bit to 24-bit multiplexed D-type latch used in applications where two separate data paths must be multiplexed onto, or demultiplexed from, a single data path. Typical applications include multiplexing and/or demultiplexing of address and data information in microprocessor or bus-interface applications. This device is also useful in memory-interleaving applications.

Three 12-bit I/O ports (A1–A12, 1B1–1B12, and 2B1–2B12) are available for address and/or data transfer. The output enable ( $\overline{OE1B}$ ,  $\overline{OE2B}$ , and  $\overline{OE A}$ ) inputs control the bus transceiver functions. The  $\overline{OE1B}$  and  $\overline{OE2B}$  control signals also allow bank control in the A to B direction.

Address and/or data information can be stored using the internal storage latches. The latch enable (LE1B, LE2B, LEA1B, and LEA2B) inputs are used to control data storage. When the latch enable input is high, the latch is transparent. When the latch enable input goes low, the data present at the inputs is latched and remains latched until the latch enable input is returned high.

To ensure the high-impedance state during power-up or power-down,  $\overline{OE}$  should be tied to  $V_{CC}$  through a pull-up resistor; the minimum value of the resistor is determined by the current sinking capability of the driver.

The 74ABTH incorporates the bus hold feature. The 74ABT does not include bus hold feature. Both parts are available in 56-pin SSOP and TSSOP.

## QUICK REFERENCE DATA

SYMBOL	PARAMETER	CONDITIONS $T_{amb} = 25^{\circ}\text{C}; \text{GND} = 0\text{V}$	TYPICAL	UNIT
$t_{PLH}$	Propagation delay	$C_L = 50 \text{ pF}$	2.8	ns
$t_{PHL}$	nAx to nBx    nBx to nAx		2.5	
$C_{IN}$	Input capacitance	$V_I = 0 \text{ V or } V_{CC}$	4	pF
$C_{OUT}$	Output capacitance	$V_{IO} = 0 \text{ V or } 5.0 \text{ V}$	6	pF
$I_{CCZ}$	Total supply current	Outputs disabled	100	$\mu\text{A}$

## ORDERING INFORMATION

PACKAGES	TEMPERATURE RANGE	OUTSIDE NORTH AMERICA	NORTH AMERICA	DWG NUMBER
56-Pin Plastic SSOP Type III	$-40^{\circ}\text{C to } +85^{\circ}\text{C}$	74ABT16260 DL	BT16260 DL	SOT371-1
56-Pin Plastic TSSOP Type II	$-40^{\circ}\text{C to } +85^{\circ}\text{C}$	74ABT16260 DGG	BT16260 DGG	SOT364-1
56-Pin Plastic SSOP Type III	$-40^{\circ}\text{C to } +85^{\circ}\text{C}$	74ABTH16260 DL	BH16260 DL	SOT371-1
56-Pin Plastic TSSOP Type II	$-40^{\circ}\text{C to } +85^{\circ}\text{C}$	74ABTH16260 DGG	BH16260 DGG	SOT364-1

## PIN DESCRIPTION

PIN NUMBER	SYMBOL	FUNCTION
8, 9, 10, 12, 13, 14, 15, 16, 17, 19, 20, 21	An	Data inputs/outputs (A)
23, 24, 26, 31, 33, 34, 36, 37, 38, 40, 41, 42	1Bn	Data inputs/outputs (B1)
6, 5, 3, 54, 52, 51, 49, 48, 47, 45, 44, 43	2Bn	Data inputs/outputs (B2)
1, 29, 56	$\overline{OE A}$ , $\overline{OE1B}$ , $\overline{OE2B}$	Output enable input (active low)
2, 27, 30, 55	LE1B, LE2B, LEA1B, LEA2B	Latch enable inputs

# 12-bit to 24-bit multiplexed D-type latches (3-State)

74ABT16260  
74ABTH16260

## PIN CONFIGURATION

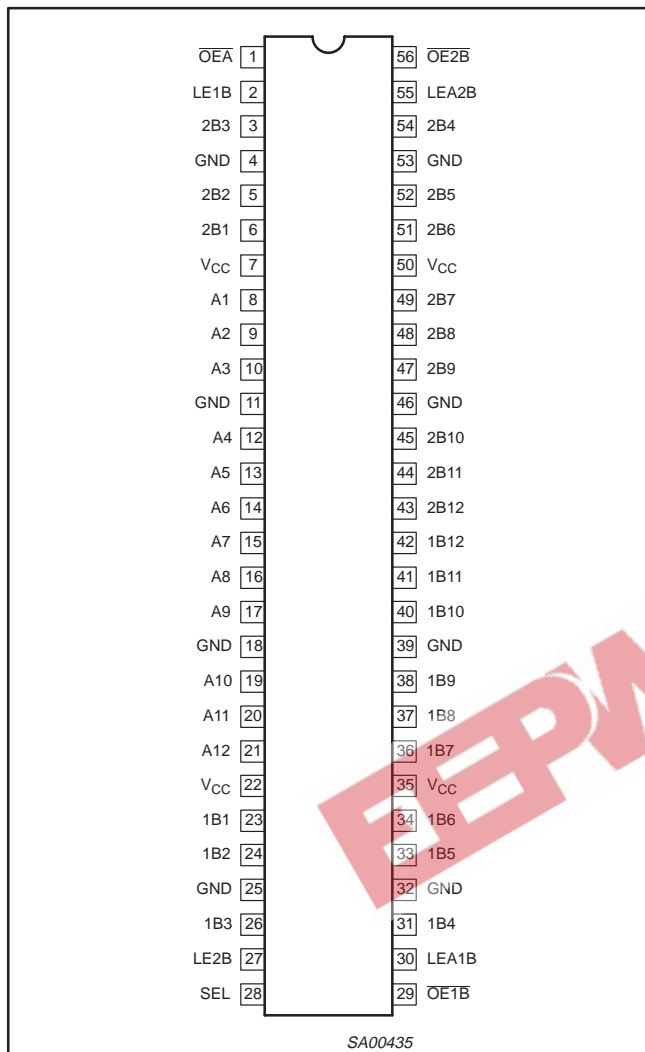

## FUNCTION TABLES

### B to A ( $\overline{OE\overline{B}} = H$ )

INPUTS						OUTPUT
1B	2B	SEL	LE1B	LE2B	$\overline{OE\overline{A}}$	A
H	X	H	H	X	L	H
L	X	H	H	X	L	L
X	X	H	L	X	L	A0
X	H	L	X	H	L	H
X	L	L	X	H	L	L
X	X	L	X	L	L	A0
X	X	X	X	X	H	Z

### A to B ( $\overline{OE\overline{A}} = H$ )

INPUTS					OUTPUT	
A	LEA1B	LEA2B	$\overline{OE1\overline{B}}$	$\overline{OE2\overline{B}}$	1B	2B
H	H	H	L	L	H	H
L	H	H	L	L	L	L
H	H	L	L	L	H	2B0
L	H	L	L	L	L	2B0
H	L	H	L	L	1B0	H
L	L	H	L	L	1B0	L
X	L	L	L	L	1B0	2B0
X	X	X	H	H	Z	Z
X	X	X	L	H	Active	Z
X	X	X	H	L	Z	Active
X	X	X	L	L	Active	Active

# 12-bit to 24-bit multiplexed D-type latches (3-State)

74ABT16260  
74ABTH16260

## LOGIC DIAGRAM (POSITIVE LOGIC)

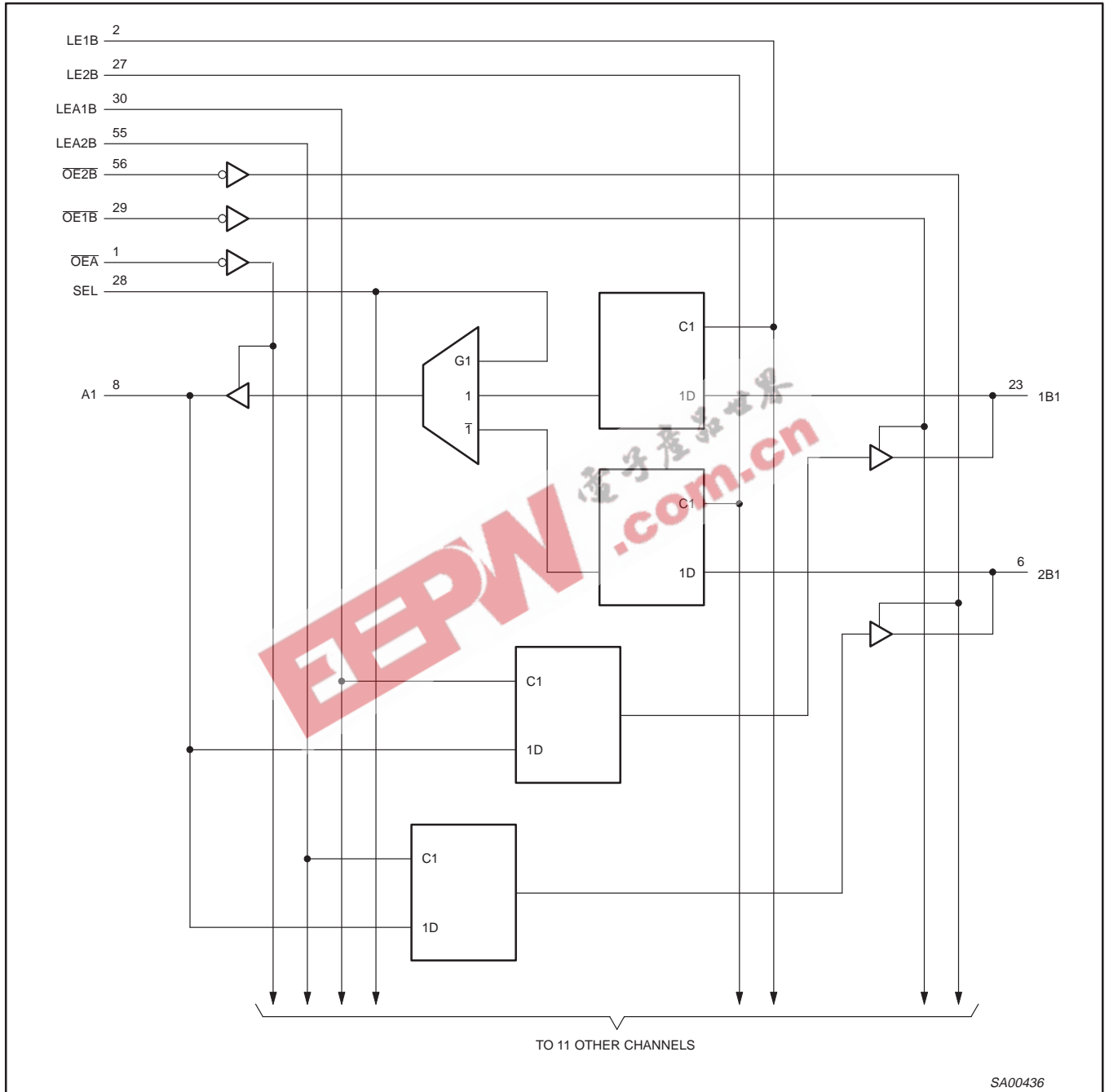

## 12-bit to 24-bit multiplexed D-type latches (3-State)

74ABT16260  
74ABTH16260**ABSOLUTE MAXIMUM RATINGS**Over operating free-air temperature range (unless otherwise specified)<sup>1</sup>

SYMBOL	PARAMETER	CONDITIONS	LIMITS		UNIT
			MIN	MAX	
V <sub>CC</sub>	Supply voltage range		-0.5	7	V
V <sub>I</sub>	Input voltage range	see Note 2	-0.5	7	V
V <sub>O</sub>	Voltage range applied to any output in the high state or power-off state		-0.5	5.5	V
I <sub>O</sub>	Current into any output in the low state			128	mA
I <sub>IK</sub>	Input clamp current	V <sub>I</sub> < 0		-18	mA
I <sub>OK</sub>	Output clamp current	V <sub>O</sub> < 0		-50	mA
	Maximum power dissipation at T <sub>amb</sub> = 55°C (in still air)	see Note 3		1.4	W
T <sub>stg</sub>	Storage temperature range		-65	+150	°C

**NOTES:**

- Stresses beyond those listed under "Absolute Maximum Ratings" may cause permanent damage to the device. These are stress ratings only, and functional operation of the device at these or any other conditions beyond those indicated under "Recommended Operating Conditions" is not implied. Exposure to absolute maximum rated conditions for extended periods may affect device reliability.
- The input and output negative-voltage ratings may be exceeded if the input and output clamp-current ratings are observed.
- The maximum package power dissipation is calculated using a junction temperature of 150°C and a board trace length of 750 mils.

**RECOMMENDED OPERATING CONDITIONS<sup>1</sup>**

SYMBOL	PARAMETER		LIMITS		UNIT
			MIN	MAX	
V <sub>CC</sub>	Supply voltage		4.5	5.5	V
V <sub>IH</sub>	High-level input voltage		2		V
V <sub>IL</sub>	Low-level input voltage			0.8	V
V <sub>I</sub>	Input voltage		0	V <sub>CC</sub>	V
I <sub>OH</sub>	High-level output current			-32	mA
I <sub>OL</sub>	Low-level output current			64	mA
ΔtΔ/v	Input transition rise or fall rate	Outputs enabled		10	ns/V
ΔtΔ/V <sub>CC</sub>	Power-up ramp rate		200		μs/V
T <sub>amb</sub>	Operating free-air temperature		-40	+85	°C

**NOTE:**

- Unused or floating inputs must be held high or low.

## 12-bit to 24-bit multiplexed D-type latches (3-State)

74ABT16260  
74ABTH16260

## DC ELECTRICAL CHARACTERISTICS

SYMBOL	PARAMETER	TEST CONDITIONS	LIMITS					UNIT
			T <sub>amb</sub> = +25°C			T <sub>amb</sub> = -40°C to +85°C		
			Min	Typ	Max	Min	Max	
V <sub>IK</sub>	Input clamp voltage	V <sub>CC</sub> = 4.5V; I <sub>IK</sub> = -18mA		-0.8	-1.2		-1.2	V
V <sub>OH</sub>	High-level output voltage	V <sub>CC</sub> = 4.5V; I <sub>OH</sub> = -3mA; V <sub>I</sub> = V <sub>IL</sub> or V <sub>IH</sub>	2.5	2.9		2.5		V
		V <sub>CC</sub> = 5.0V; I <sub>OH</sub> = -3mA; V <sub>I</sub> = V <sub>IL</sub> or V <sub>IH</sub>	3.0	3.4		3.0		V
		V <sub>CC</sub> = 4.5V; I <sub>OH</sub> = -32mA; V <sub>I</sub> = V <sub>IL</sub> or V <sub>IH</sub>	2.0	2.4		2.0		V
V <sub>OL</sub>	Low-level output voltage	V <sub>CC</sub> = 4.5V; I <sub>OL</sub> = 64mA; V <sub>I</sub> = V <sub>IL</sub> or V <sub>IH</sub>		0.42	0.55		0.55	V
I <sub>I</sub>	Input leakage current	V <sub>CC</sub> = 5.5V; V <sub>I</sub> = V <sub>CC</sub> or GND		±0.01	±1		±1	µA
		V <sub>CC</sub> = 5.5V; V <sub>I</sub> = V <sub>CC</sub> or GND			±3		±5	µA
I <sub>HOLD</sub>	Bus Hold current	V <sub>CC</sub> = 4.5V; V <sub>I</sub> = 0.8V	75			75		µA
		V <sub>CC</sub> = 4.5V; V <sub>I</sub> = 2.0V	-75			-75		
		V <sub>CC</sub> = 5.5V; V <sub>I</sub> = 0 to 5.5V	±500			±500		
I <sub>OFF</sub>	Power-off leakage current	V <sub>CC</sub> = 0.0V; V <sub>O</sub> or V <sub>I</sub> ≤ 4.5V		±5.0	±100		±100	µA
I <sub>PU</sub> /I <sub>PD</sub>	Power-up/down 3-State output current	V <sub>CC</sub> = 2.0V; V <sub>O</sub> = 0.5V; V <sub>I</sub> = GND or V <sub>CC</sub> ; V <sub>OE</sub> = V <sub>CC</sub>		±60	±200		±200	µA
I <sub>OZH</sub>	3-State output High current	V <sub>CC</sub> = 5.5V; V <sub>O</sub> = 2.7V; V <sub>I</sub> = V <sub>IL</sub> or V <sub>IH</sub>		1.0	10		10	µA
I <sub>OZL</sub>	3-State output Low current	V <sub>CC</sub> = 5.5V; V <sub>O</sub> = 0.5V; V <sub>I</sub> = V <sub>IL</sub> or V <sub>IH</sub>		-1.0	-10		-10	µA
I <sub>CEX</sub>	Output high leakage current	V <sub>CC</sub> = 5.5V; V <sub>O</sub> = 5.5V; V <sub>I</sub> = GND or V <sub>CC</sub>			50		50	µA
I <sub>O</sub>	Output current <sup>1</sup>	V <sub>CC</sub> = 5.5V; V <sub>O</sub> = 2.5V	-50	-100	-225	-50	-225	mA
I <sub>CC</sub>	Quiescent supply current	V <sub>CC</sub> = 5.5V; Outputs High, V <sub>I</sub> = GND or V <sub>CC</sub>		0.2	1.5		1.5	mA
		V <sub>CC</sub> = 5.5V; Outputs Low, V <sub>I</sub> = GND or V <sub>CC</sub>		8	19		19	
		V <sub>CC</sub> = 5.5V; Outputs 3-State; V <sub>I</sub> = GND or V <sub>CC</sub>		0.1	1.0		1.0	
ΔI <sub>CC</sub>	Additional supply current per input pin <sup>2</sup>	Outputs enabled, one input at 3.4V, other inputs at V <sub>CC</sub> or GND; V <sub>CC</sub> = 5.5V		0.1	1.5		1.5	mA

## NOTES:

- Not more than one output should be tested at a time, and the duration of the test should not exceed one second.
- This is the increase in supply current for each input that is at the specified TTL voltage level rather than V<sub>CC</sub> or GND.
- This is the bus hold minimum overdrive current required to force the input to the opposite logic state.

## 12-bit to 24-bit multiplexed D-type latches (3-State)

74ABT16260  
74ABTH16260**AC ELECTRICAL CHARACTERISTICS**

Over recommended operating free-air temperature range (unless otherwise noted)

SYMBOL	PARAMETER		$V_{CC} = 5V, T_{amb} = 25^{\circ}C$			$T_{amb} = -40^{\circ}C \text{ to } +85^{\circ}C$		UNIT
	FROM (INPUT)	TO (OUTPUT)	MIN	TYP	MAX	MIN	MAX	
$t_{PLH}$	A or B	B or A	1	2.8	4.8	1	5.6	ns
$t_{PHL}$			1	2.5	5	1	5.9	ns
$t_{PLH}$	$\overline{LE}$	A or B	1.1	3.2	4.9	1.1	5.8	ns
$t_{PHL}$			1.1	3.2	4.9	1.1	5.3	ns
$t_{PLH}$	SEL (B1)	A	1.3	3.2	4.6	1.3	5.3	ns
	SEL (B2)	A	1.1	2.8	4.9	1.1	6	ns
$t_{PHL}$	SEL (B1)	A	1.5	3.0	4.4	1.5	4.4	ns
	SEL (B2)	A	1.6	2.6	5.1	1.6	5.9	ns
$t_{PZH}$	$\overline{OE}$	A or B	1	2.9	4.7	1	5.7	ns
$t_{PZL}$			1.6	2.2	5.1	1.6	5.8	ns
$t_{PHZ}$	$\overline{OE}$	A or B	2.2	4.1	5.4	2.2	6.4	ns
$t_{PLZ}$			1.3	3.2	4.4	1.3	4.8	ns

**AC SETUP CHARACTERISTICS**

Over recommended operating free-air temperature range (unless otherwise noted)

SYMBOL	PARAMETER	$V_{CC} = 5V, T_{amb} = 25^{\circ}C$		$T_{amb} = -40^{\circ}C \text{ to } +85^{\circ}C$		UNIT
		MIN	MAX	MIN	MAX	
$t_w$	Pulse duration, LE1B, LE2B, LEA1B, or LEA2B high	3.3		3.3		ns
$t_{su}$	Setup time, data before LE1B, LE2B, LEA1B, or LEA2B↓	1.5		1.5		ns
$t_h$	Hold time, data after LE1B, LE2B, LEA1B, or LEA2B↓	1		1		ns

# 12-bit to 24-bit multiplexed D-type latches (3-State)

74ABT16260  
74ABTH16260

## AC WAVEFORMS

$V_M = 1.5V$  for all waveforms

The outputs are measured one at a time with one transition per measurement.

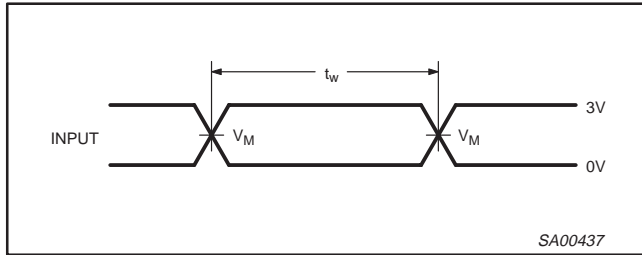

Figure 1. Pulse duration

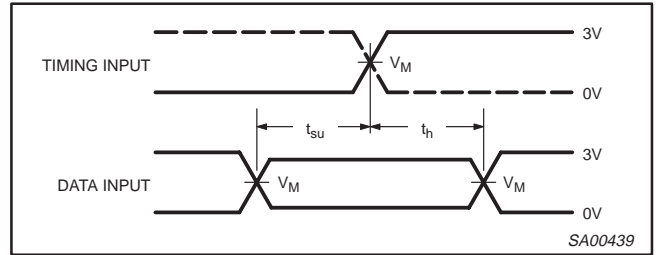
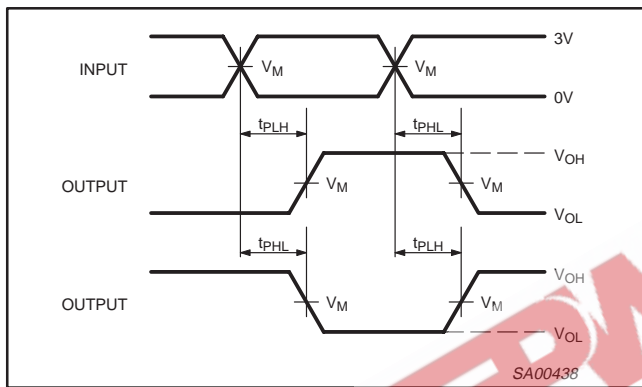
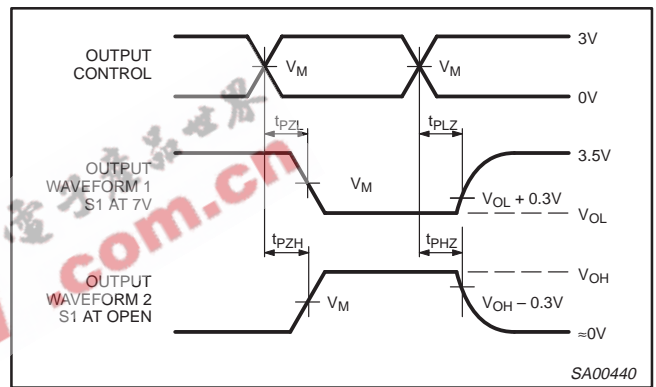

Figure 3. Setup and hold times



All input pulses are supplied by generators having the following characteristics:  $PRR \leq 10MHz$ ,  $Z_O = 50\Omega$ ,  $t_r \leq 2.5ns$ ,  $t_f \leq 2.5ns$ .

Figure 2. Propagation delay times; inverting and non-inverting outputs



Waveform 1 is for an output with internal conditions such that the output is low except when disabled by the output control. Waveform 2 is for an output with internal conditions such that the output is high except when disabled by the output control.

Figure 4. Enable and disable times; low- and high-level enabling

## TEST LOAD CIRCUIT

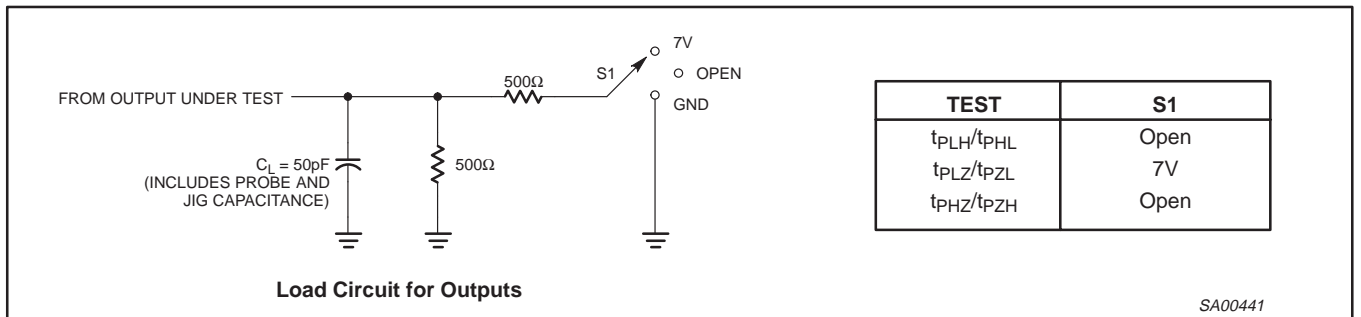

Figure 5. Test load circuit



12-bit to 24-bit multiplexed D-type latches (3-State)

74ABT16260  
74ABTH16260

SSOP56: plastic shrink small outline package; 56 leads; body width 7.5 mm

SOT371-1

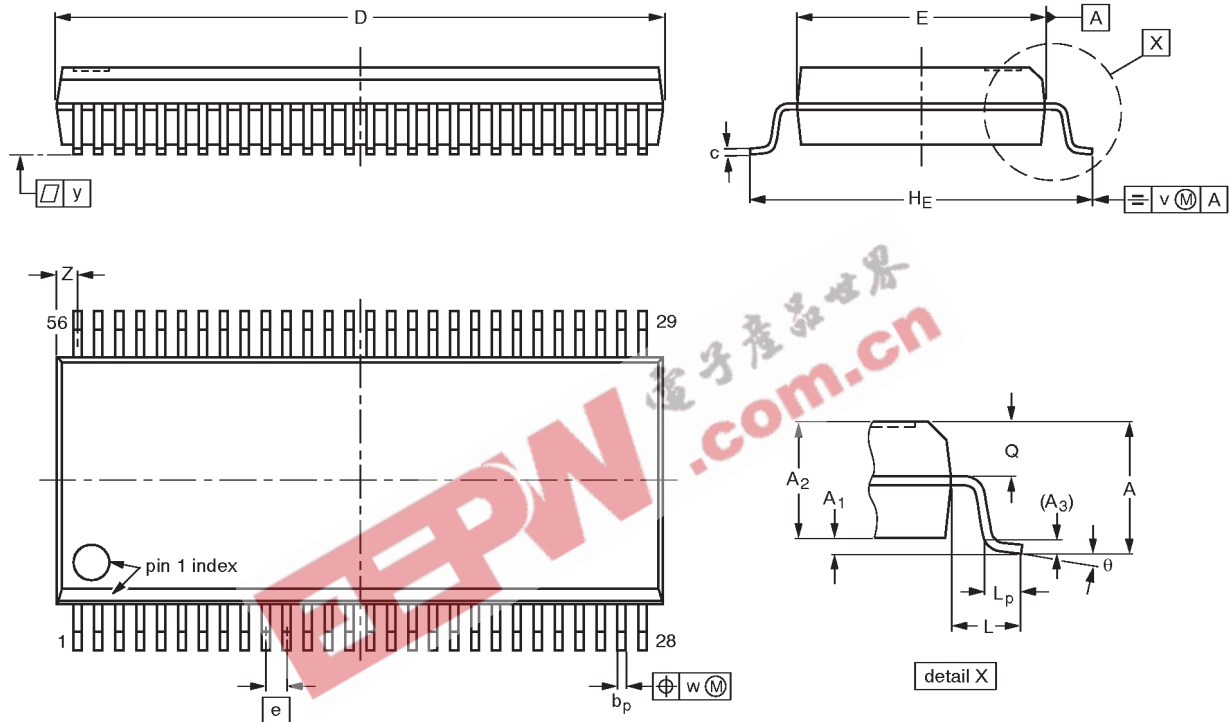

DIMENSIONS (mm are the original dimensions)

UNIT	A max.	A <sub>1</sub>	A <sub>2</sub>	A <sub>3</sub>	b <sub>p</sub>	c	D <sup>(1)</sup>	E <sup>(1)</sup>	e	H <sub>E</sub>	L	L <sub>p</sub>	Q	v	w	y	Z <sup>(1)</sup>	θ
mm	2.8	0.4 0.2	2.35 2.20	0.25	0.3 0.2	0.22 0.13	18.55 18.30	7.6 7.4	0.635	10.4 10.1	1.4	1.0 0.6	1.2 1.0	0.25	0.18	0.1	0.85 0.40	8° 0°

Note

1. Plastic or metal protrusions of 0.25 mm maximum per side are not included.

OUTLINE VERSION	REFERENCES				EUROPEAN PROJECTION	ISSUE DATE
	IEC	JEDEC	EIAJ			
SOT371-1		MO-118AB				93-11-02 95-02-04

12-bit to 24-bit multiplexed D-type latches (3-State)

74ABT16260  
74ABTH16260

TSSOP56: plastic thin shrink small outline package; 56 leads; body width 6.1mm

SOT364-1

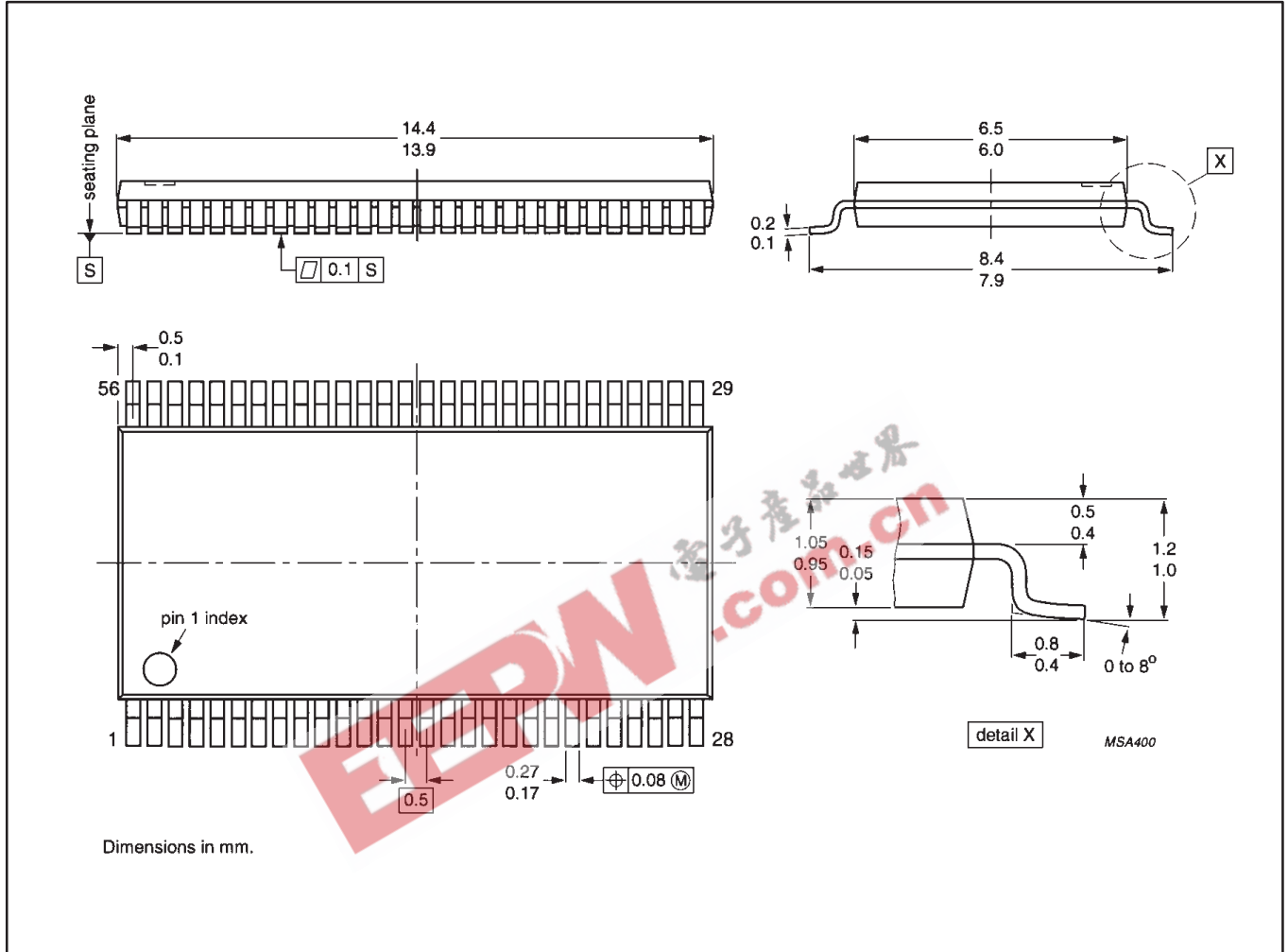

---

12-bit to 24-bit multiplexed D-type latches (3-State)

74ABT16260  
74ABTH16260

---

NOTES



## 12-bit to 24-bit multiplexed D-type latches (3-State)

74ABT16260  
74ABTH16260

## Data sheet status

Data sheet status	Product status	Definition [1]
Objective specification	Development	This data sheet contains the design target or goal specifications for product development. Specification may change in any manner without notice.
Preliminary specification	Qualification	This data sheet contains preliminary data, and supplementary data will be published at a later date. Philips Semiconductors reserves the right to make changes at any time without notice in order to improve design and supply the best possible product.
Product specification	Production	This data sheet contains final specifications. Philips Semiconductors reserves the right to make changes at any time without notice in order to improve design and supply the best possible product.

[1] Please consult the most recently issued datasheet before initiating or completing a design.

## Definitions

**Short-form specification** — The data in a short-form specification is extracted from a full data sheet with the same type number and title. For detailed information see the relevant data sheet or data handbook.

**Limiting values definition** — Limiting values given are in accordance with the Absolute Maximum Rating System (IEC 134). Stress above one or more of the limiting values may cause permanent damage to the device. These are stress ratings only and operation of the device at these or at any other conditions above those given in the Characteristics sections of the specification is not implied. Exposure to limiting values for extended periods may affect device reliability.

**Application information** — Applications that are described herein for any of these products are for illustrative purposes only. Philips Semiconductors make no representation or warranty that such applications will be suitable for the specified use without further testing or modification.

## Disclaimers

**Life support** — These products are not designed for use in life support appliances, devices or systems where malfunction of these products can reasonably be expected to result in personal injury. Philips Semiconductors customers using or selling these products for use in such applications do so at their own risk and agree to fully indemnify Philips Semiconductors for any damages resulting from such application.

**Right to make changes** — Philips Semiconductors reserves the right to make changes, without notice, in the products, including circuits, standard cells, and/or software, described or contained herein in order to improve design and/or performance. Philips Semiconductors assumes no responsibility or liability for the use of any of these products, conveys no license or title under any patent, copyright, or mask work right to these products, and makes no representations or warranties that these products are free from patent, copyright, or mask work right infringement, unless otherwise specified.

Philips Semiconductors  
811 East Arques Avenue  
P.O. Box 3409  
Sunnyvale, California 94088-3409  
Telephone 800-234-7381

© Copyright Philips Electronics North America Corporation 1998  
All rights reserved. Printed in U.S.A.

print code

Date of release: 05-96

Document order number:

9397-750-03339

*Let's make things better.*