

DATA SHEET

EEPW 电子產品世界
.com.cn

74LVC1284

3.3V Parallel printer interface
transceiver/buffer

Product specification

1995 Nov 10

IC24 Low Voltage Handbook

3.3V Parallel printer interface transceiver/buffer

74LVC1284

FEATURES

- Asynchronous operation
- 4-Bit transceivers
- 3 additional buffer/driver lines
- TTL compatible inputs
- ESD protection exceeds 1000V per MIL STD 883 Method 3015 and 200V per Machine Model
- Input Hysteresis
- Low Noise Operation
- Center Pin V_{CC} & GND
- IEEE 1284 Compliant Level 1 & 2
- Overvoltage Protection on B side

DESCRIPTION

The 74LVC1284 parallel interface chip is designed to provide an asynchronous, 4-bit, bi-directional, parallel printer interface for personal computers. Three additional lines are included to provide handshaking signals between the host and the peripheral. The part is designed to match IEEE 1284 standard.

The 4 transceiver pins (A/B 1-4) allow data transmission from the A bus to the B bus, or from the B bus to the A bus, depending on the state of the direction pin DIR.

The B bus and the Y5-Y7 lines have totem pole or open drain style outputs depending on the state of the high drive enable pin HD. The A bus only has totem pole style outputs. All inputs are TTL compatible with at least 300mV of input hysteresis at $V_{CC} = 3.3V$.

QUICK REFERENCE DATA

SYMBOL	PARAMETER	CONDITIONS $T_{amb} = 25^{\circ}C; GND = 0V$	TYPICAL	UNIT
R_D	B/Y Side output resistance	$V_{CC} = 3.3V; V_O = 1.65V \pm 0.2V$ (See Figure 2)	45	Ω
SR	B/Y Side slew rate	$R_L = 62\Omega; C_L = 50pF$ (See Waveform 4)	0.2	V/ns
I_{CC}	Total static current	$V_I = V_{CC}/GND; I_O = 0$	5	μA
V_{HYS}	Input hysteresis	$V_{CC} = 3.3V$	0.4	V
t_{PLH}/t_{PHL} A-B/Y	Propagation delay to the B/Y side outputs	$V_{CC} = 3.3V$	12.6/12.4	ns

ORDERING INFORMATION

PACKAGES	TEMPERATURE RANGE	ORDER CODE	DRAWING NUMBER
20-pin plastic SO	0°C to +70°C	7LVC1284 D	SOT163-1
20-pin plastic SSOP Type II	0°C to +70°C	74LVC1284 DB	SOT339-1
20-pin plastic TSSOP Type I	0°C to +70°C	74LVC1284 PW	SOT360-1

PIN CONFIGURATION

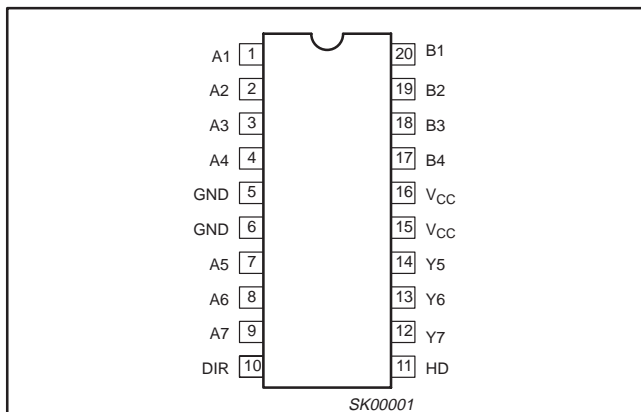

LOGIC SYMBOL

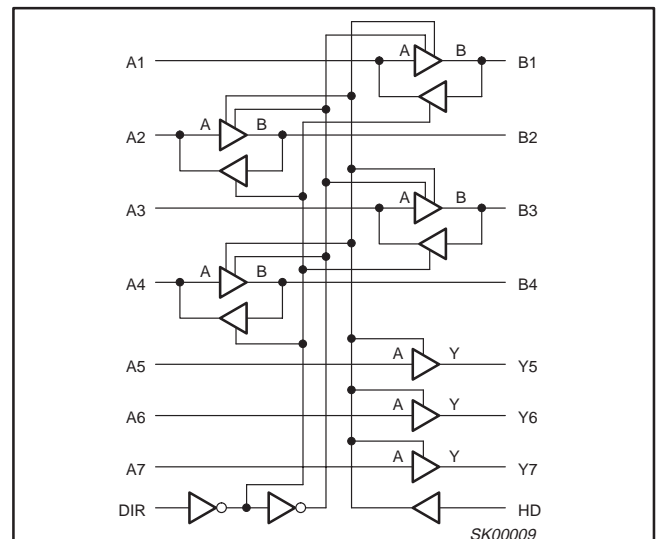

3.3V Parallel printer interface transceiver/buffer

74LVC1284

PIN DESCRIPTION

PIN NUMBER	SYMBOL	FUNCTION
1,2,3,4	A1 - A4	Data inputs/outputs
20,19,18,17	B1 - B4	IEEE 1284 Std. outputs/inputs
7,8,9	A5 - A7	Data inputs
14,13,12	Y5 - Y7	IEEE 1284 Std. outputs
10	DIR	Direction selection
11	HD	B/Y-side high drive enable/disable
5,6	GND	Ground (0V)
15,16	V _{CC}	Positive supply voltage

FUNCTION TABLE

INPUTS			OUTPUTS	INPUTS/OUTPUTS	
DIR	HD	A5-7	Y5-7	A1-4	B1-4
L	L	L	L	A = B	Inputs
L	L	H	Z	A = B	Inputs
L	H	L	L	A = B	Inputs
L	H	H	H	A = B	Inputs
H	L	L	L	Inputs Low	Outputs Low
H	L	H	Z	Inputs High	Outputs Z
H	H	L	L	Inputs	B = A
H	H	H	H	Inputs	B = A

H = High Voltage
 L = Low Voltage
 Z = High Impedance, Off-State

ABSOLUTE MAXIMUM RATINGS^{1, 2}

SYMBOL	PARAMETER	CONDITIONS	RATING	UNIT
	ESD Immunity, per Mil Std 883C method 3015		±2	kV
V _{CC}	DC supply voltage		-0.5 to +4.6	V
I _{IK}	DC input diode current	V _I < 0	±20	mA
I _{OK}	DC output diode current	V _O < 0	±50	mA
V _{IN}	DC input voltage ³		-0.5 to +5.5	V
V _{OUT B/YDC}	DC output voltage on B/Y side ³		-0.5 to +5.5	V
V _{OUT B/Y (tr)}	Transient output voltage on B/Y side ⁴	40ns transient	-2 to +7	V
V _{OUT A side}	DC output voltage on A side		-0.5 to V _{CC} + 0.5	V
I _O	DC output current	Outputs in High or Low state	±50	mA
T _{stg}	Storage temperature range		-60 to +150	°C
I _{CC} /I _{GND}	Continuous current through V _{CC} or GND		±200	mA

NOTES:

- Stresses beyond those listed may cause permanent damage to the device. These are stress ratings only and functional operation of the device at these or any other conditions beyond those indicated under "recommended operating conditions" is not implied. Exposure to absolute-maximum-rated conditions for extended periods may affect device reliability.
- The performance capability of a high-performance integrated circuit in conjunction with its thermal environment can create junction temperatures which are detrimental to reliability. The maximum junction temperature of this integrated circuit should not exceed 150°C.
- The input and output voltage ratings may be exceeded if the input and output current ratings are observed.
- V_{OUT B/Y (tr)} guarantees only that this part will not be damaged by reflections in application so long as the voltage levels remain in the specified range.

RECOMMENDED OPERATING CONDITIONS

SYMBOL	PARAMETER	LIMITS		UNIT
		MIN	MAX	
V _{CC}	DC supply voltage	3.0	3.6	V
V _I	Input voltage	0	V _{CC}	V
V _{OUT}	B/Y output voltage	-0.5	5.5	V
V _{OUT}	A side output voltage	0	V _{CC}	V
I _{OH}	B/Y side output current High		-14	mA
I _{OL}	B/Y side output current Low		14	mA
T _{amb}	Operating free-air temperature range	0	+70	°C

3.3V Parallel printer interface transceiver/buffer

74LVC1284

DC ELECTRICAL CHARACTERISTICS

SYMBOL	PARAMETER		TEST CONDITIONS	LIMITS					UNIT
				T _{amb} = 25°C			T _{amb} = 0°C to +70°C		
				MIN	TYP	MAX	MIN	MAX	
V _{OH}	High-level output voltage	An	V _{CC} = Min to Max; I _{OH} = -50μA	V _{CC} -0.2	V _{CC}		V _{CC} -0.2		V
		Bn or Yn	V _{CC} = 3.0V; I _{OH} = -4mA	2.4			2.4		V
			V _{CC} = 3.0V; I _{OH} = 14mA	2.2	2.4		2.1		V
V _{OL}	Low-level output voltage	An	V _{CC} = Min to Max; I _{OL} = 50μA; V _I = V _{IL} or V _{IH}			0.2		0.2	V
			V _{CC} = 3.0V; I _{OL} = 4mA; V _I = V _{IL} or V _{IH}			0.4		0.4	V
		Bn or Yn	V _{CC} = 3.0V; I _{OL} = -14mA; V _I = V _{IL} or V _{IH}			0.8		0.9	V
V _{IH}	High-level input voltage		V _{CC} = Min to Max			0.8		0.8	
V _{IL}	Low-level input voltage		V _{CC} = Min to Max	2.0			2.0		
V _{HYS}	Input Hysteresis		V _{CC} = 3.3V		0.4		0.3		V
R _D	B/Y side Output Impedance		See Figure 2	38	45	53	35	55	Ω
I _I	Input leakage current (A5-A7 DIR, HD)		V _{CC} = 3.6V; V _O = V _{CC} or GND; Not for I/O pins			±1.0		±5.0	μA
I _{IHZ} /I _{ILZ}	Input current for common I/O pins		V _{CC} = 3.6V; V _I = 5.5V or GND		±0.1	±15			μA
I _{OFF}	B/Y Side Power-off leakage current		V _{CC} = 0.0V; V _O = 0 to 5.5V			±10		±100	μA
I _{OZH}	3-State output High current Yn		V _{CC} = 3.6V; V _O = V _{CC} ; V _I = V _{IL} or V _{IH}			5		20	μA
I _{OZL}	3-State output Low current Yn		V _{CC} = 3.6V; V _O = GND; V _I = V _{IL} or V _{IH}			-5		-20	μA
I _{IH} +I _{OZH}	current (A1 - A4, Bn)		V _{CC} = 3.6V; V _{I/O} = V _{CC}			5		25	μA
I _{IL} +I _{OZL}	current (A1 - A4, Bn)		V _{CC} = 3.6V; V _{I/O} = GND			-5		-25	μA
I _{CC}	Quiescent Supply Current		V _{CC} = 3.6V; I _O = 0; V _I = GND or V _{CC}		5	10		50	μA

AC CHARACTERISTICS

GND = 0V, t_R = t_F = 3.0ns, C_L = 50pF, R_L = 500Ω

SYMBOL	PARAMETER		WAVEFORM	LIMITS					UNIT
				T _{amb} = 25°C V _{CC} = 3.3V			T _{amb} = 0 to +70°C V _{CC} = Min to Max		
				MIN	TYP	MAX	MIN	MAX	
SR	B-Side Slew Rate		4	0.05	0.2	0.35	0.05	0.4	V/ns
t _{PLH} t _{PHL}	Propagation delay A to Y or A to B		5	6.0	12.6	18.0	5.0	19.5	ns
t _{PLH} t _{PHL}	Propagation delay B to A		1	1.5	5.5	7.9	1.5	9.5	ns
t _{PZH} t _{PHZ}	Output enable/disable time to/from High level HD to Y or HD to B		2	4.0	12.0	16.0	4.0	20.0	ns
t _{PZL} t _{PLZ}	Output enable/disable time to/from Low level A to Y or A to B		2	5.0	12.7	16.3	5.0	20.0	ns
t _{PZH} t _{PZL}	Output enable time from DIR to B		2	8.0	12.3	18.0	4.0	20.0	ns
t _{PHZ} t _{PLZ}	Output disable time from DIR to B		2	5.0	8.9	12.5	2.0	14.5	ns
t _{PZH} t _{PZL}	Output enable time from DIR to A		2	3.5	6.9	13.0	3.0	14.5	ns
t _{PHZ} t _{PLZ}	Output disable from DIR to A		2	2.5	3.7	5.5	2.0	6.0	ns

3.3V Parallel printer interface transceiver/buffer

74LVC1284

AC WAVEFORMS

$V_M = 1.5V$

$V_X = V_{OL} \pm 0.3V$

$V_Y = V_{OH} - 0.3V$

V_{OL} and V_{OH} are the typical output voltage drops that occur with the output load. (V_{CC} never goes below 3.0V).

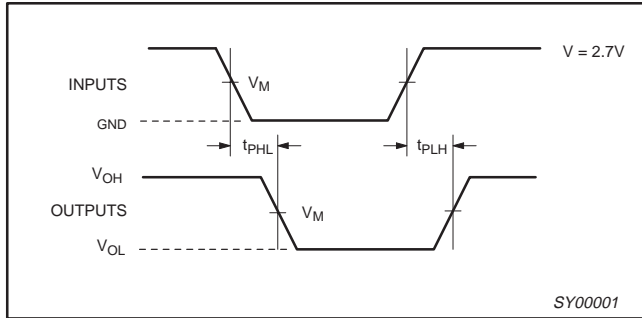

Waveform 1. Input Bn to output An propagation delays

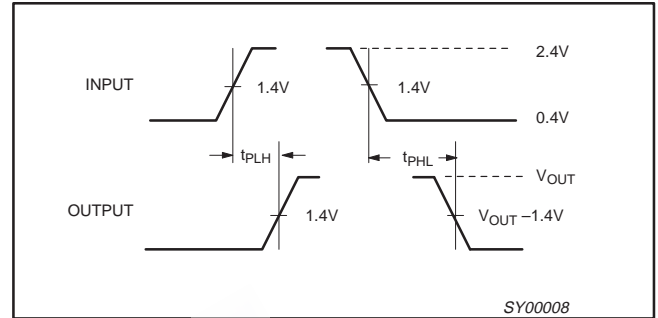

Waveform 3. Voltage Waveforms Propagation Delay Times (A To B) Measured at Output Pin

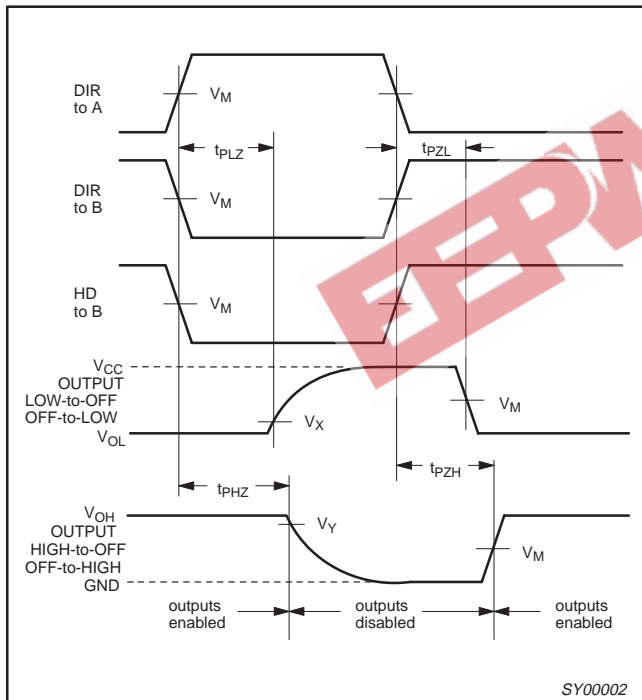

Waveform 2. 3-State enable and disable times

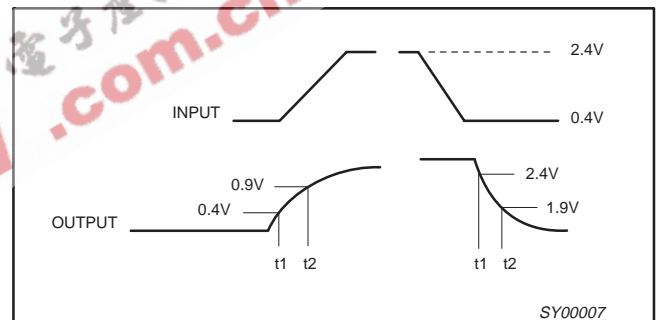

Waveform 4. Slew Rate Waveforms Voltage Waveforms
 (Input pulse rise and fall time are 3ns, 150ns < pulse width < 10 μs, for both a Low to High and a High to Low transition.)
 Slew Rate measured between 0.4V and 0.9V - rising.
 Slew Rate measured between 2.4V and 1.9V - falling.
 Slew Rate measured at TP1.

3.3V Parallel printer interface transceiver/buffer

74LVC1284

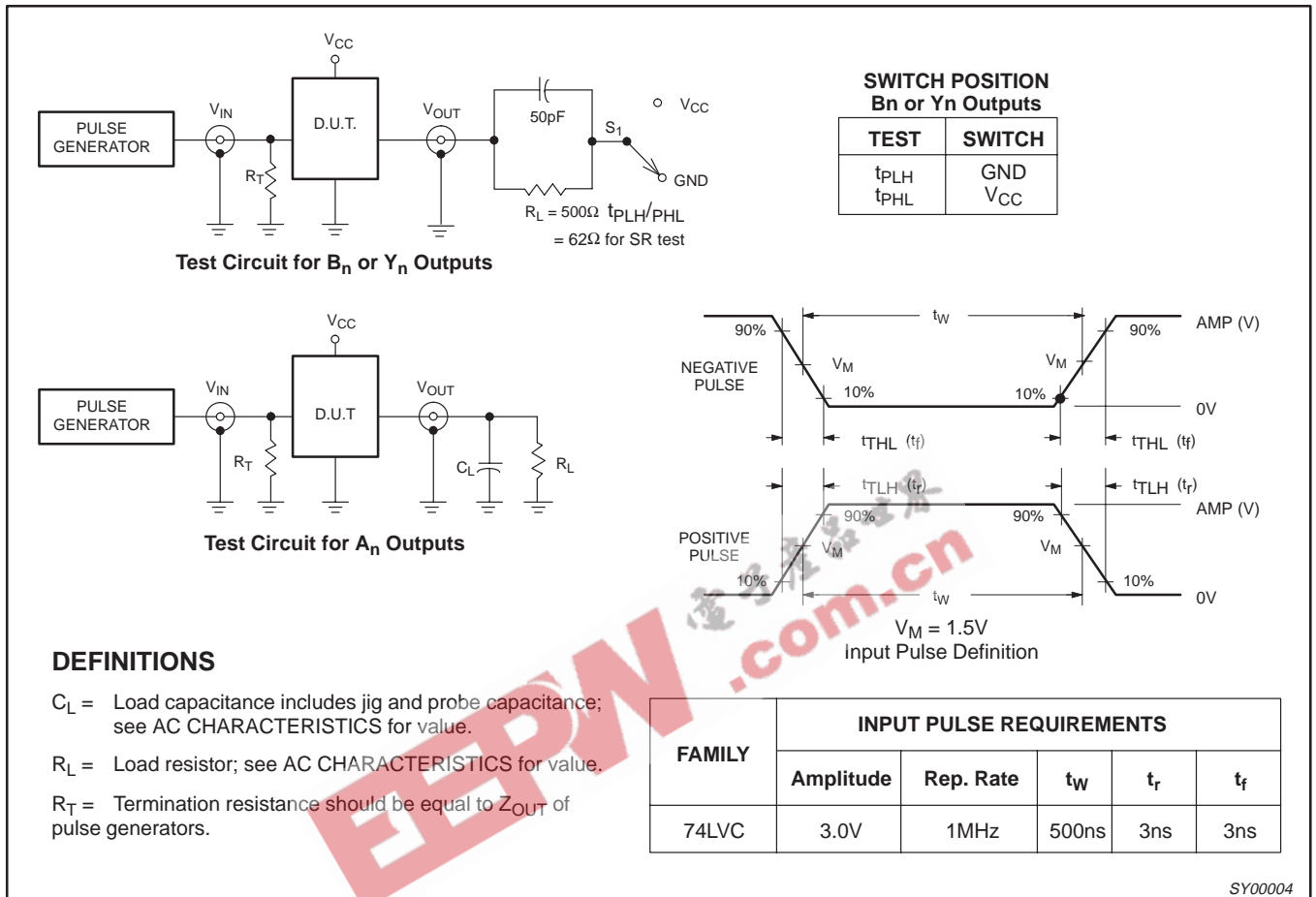

Waveform 5.

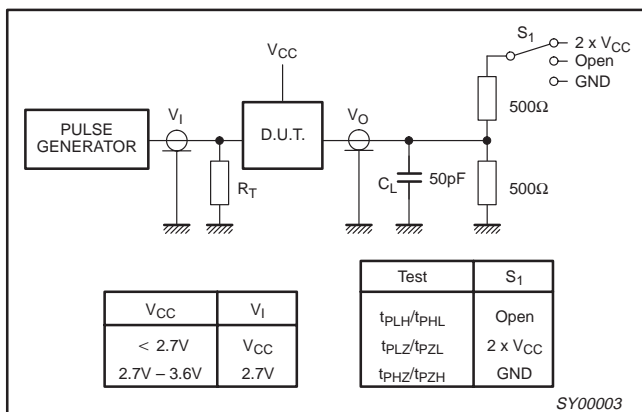

Figure 1. Load Circuitry for B_n to A_n Switching Times

TEST CIRCUIT

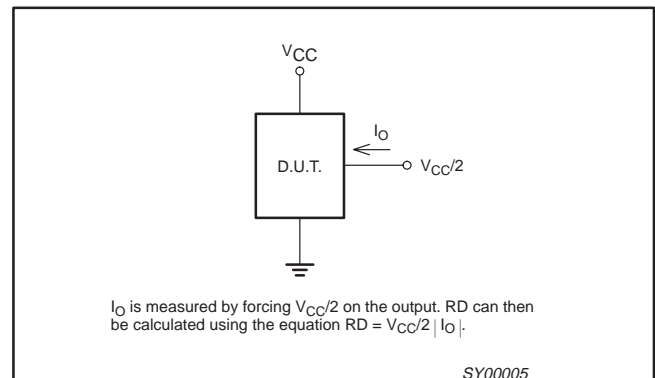

Figure 2. Output Impedance R_D

3.3V Parallel printer interface transceiver/buffer

74LVC1284

SO20: plastic small outline package; 20 leads; body width 7.5 mm

SOT163-1

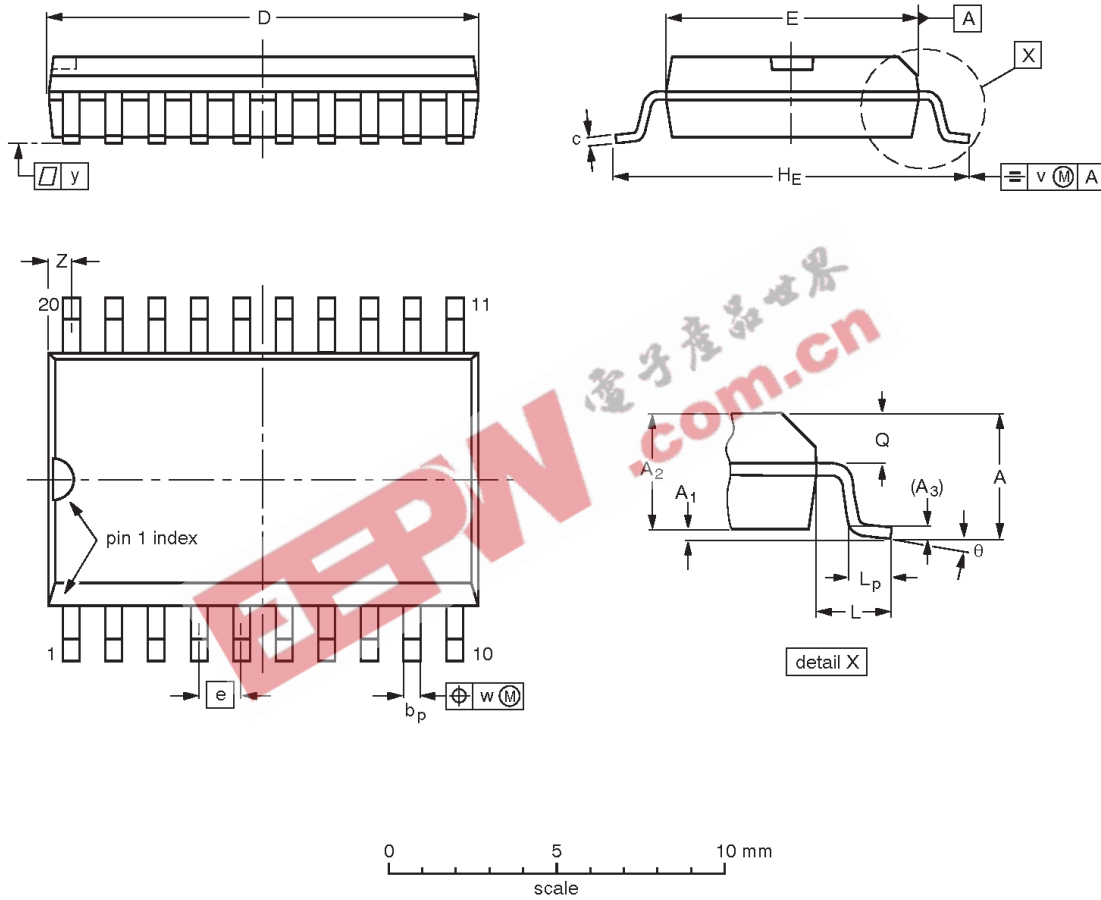

DIMENSIONS (inch dimensions are derived from the original mm dimensions)

UNIT	A max.	A ₁	A ₂	A ₃	b _p	c	D ⁽¹⁾	E ⁽¹⁾	e	H _E	L	L _p	Q	v	w	y	z ⁽¹⁾	θ
mm	2.65	0.30 0.10	2.45 2.25	0.25	0.49 0.36	0.32 0.23	13.0 12.6	7.6 7.4	1.27	10.65 10.00	1.4	1.1 0.4	1.1 1.0	0.25	0.25	0.1	0.9 0.4	8° 0°
inches	0.10	0.012 0.004	0.096 0.089	0.01	0.019 0.014	0.013 0.009	0.51 0.49	0.30 0.29	0.050	0.42 0.39	0.055	0.043 0.016	0.043 0.039	0.01	0.01	0.004	0.035 0.016	

Note

1. Plastic or metal protrusions of 0.15 mm maximum per side are not included.

OUTLINE VERSION	REFERENCES				EUROPEAN PROJECTION	ISSUE DATE
	IEC	JEDEC	EIAJ			
SOT163-1	075E04	MS-013AC				92-11-17 95-01-24

3.3V Parallel printer interface transceiver/buffer

74LVC1284

SSOP20: plastic shrink small outline package; 20 leads; body width 5.3 mm

SOT339-1

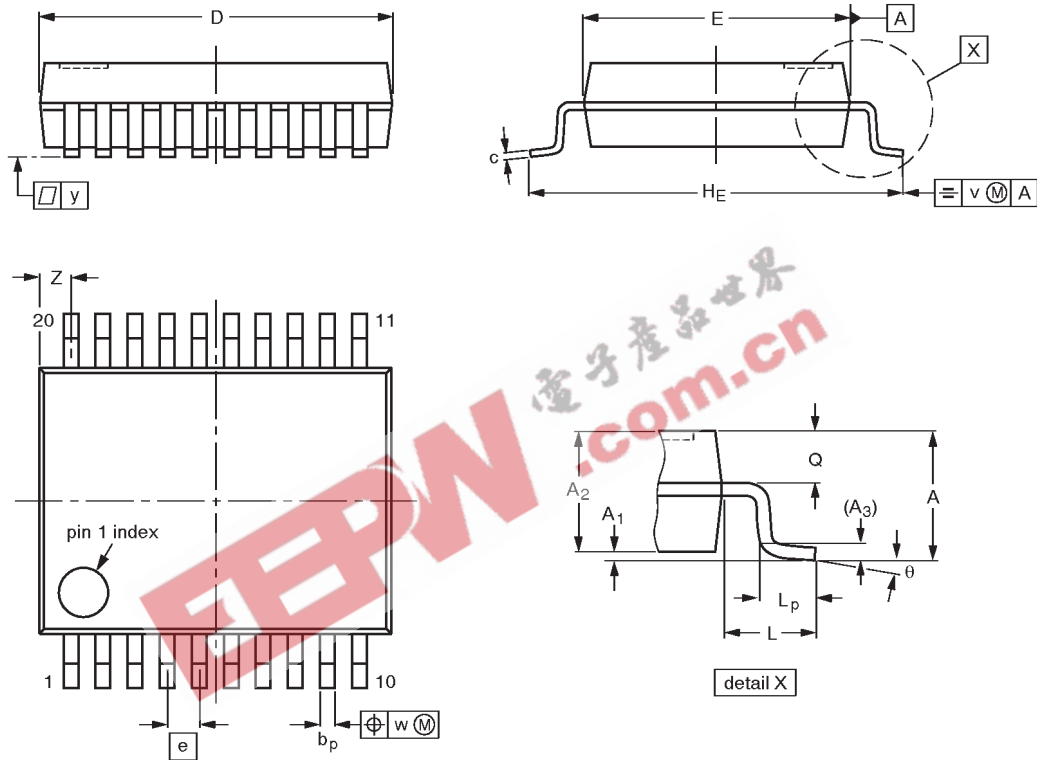

DIMENSIONS (mm are the original dimensions)

UNIT	A max.	A ₁	A ₂	A ₃	b _p	c	D ⁽¹⁾	E ⁽¹⁾	e	H _E	L	L _p	Q	v	w	y	z ⁽¹⁾	θ
mm	2.0	0.21 0.05	1.80 1.65	0.25	0.38 0.25	0.20 0.09	7.4 7.0	5.4 5.2	0.65	7.9 7.6	1.25	1.03 0.63	0.9 0.7	0.2	0.13	0.1	0.9 0.5	8° 0°

Note

1. Plastic or metal protrusions of 0.20 mm maximum per side are not included.

OUTLINE VERSION	REFERENCES				EUROPEAN PROJECTION	ISSUE DATE
	IEC	JEDEC	EIAJ			
SOT339-1		MO-150AE				93-09-08 95-02-04

3.3V Parallel printer interface transceiver/buffer

74LVC1284

TSSOP20: plastic thin shrink small outline package; 20 leads; body width 4.4 mm

SOT360-1

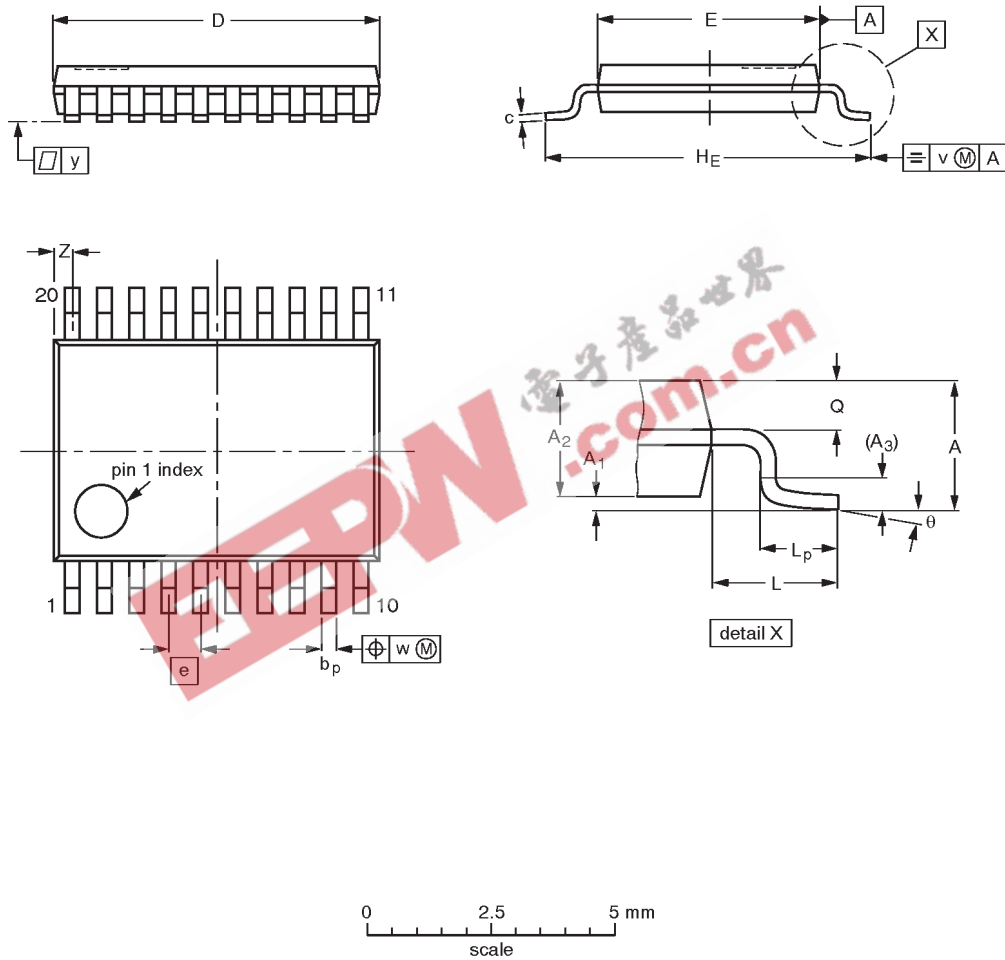

DIMENSIONS (mm are the original dimensions)

UNIT	A max.	A ₁	A ₂	A ₃	b _p	c	D ⁽¹⁾	E ⁽²⁾	e	H _E	L	L _p	Q	v	w	y	Z ⁽¹⁾	θ
mm	1.10	0.15 0.05	0.95 0.80	0.25	0.30 0.19	0.2 0.1	6.6 6.4	4.5 4.3	0.65	6.6 6.2	1.0	0.75 0.50	0.4 0.3	0.2	0.13	0.1	0.5 0.2	8° 0°

Notes

1. Plastic or metal protrusions of 0.15 mm maximum per side are not included.
2. Plastic interlead protrusions of 0.25 mm maximum per side are not included.

OUTLINE VERSION	REFERENCES				EUROPEAN PROJECTION	ISSUE DATE
	IEC	JEDEC	EIAJ			
SOT360-1		MO-153AC				93-06-16 95-02-04

3.3V Parallel printer interface transceiver/buffer

74LVC1284

Data sheet status

Data sheet status	Product status	Definition [1]
Objective specification	Development	This data sheet contains the design target or goal specifications for product development. Specification may change in any manner without notice.
Preliminary specification	Qualification	This data sheet contains preliminary data, and supplementary data will be published at a later date. Philips Semiconductors reserves the right to make changes at any time without notice in order to improve design and supply the best possible product.
Product specification	Production	This data sheet contains final specifications. Philips Semiconductors reserves the right to make changes at any time without notice in order to improve design and supply the best possible product.

[1] Please consult the most recently issued datasheet before initiating or completing a design.

Definitions

Short-form specification — The data in a short-form specification is extracted from a full data sheet with the same type number and title. For detailed information see the relevant data sheet or data handbook.

Limiting values definition — Limiting values given are in accordance with the Absolute Maximum Rating System (IEC 134). Stress above one or more of the limiting values may cause permanent damage to the device. These are stress ratings only and operation of the device at these or at any other conditions above those given in the Characteristics sections of the specification is not implied. Exposure to limiting values for extended periods may affect device reliability.

Application information — Applications that are described herein for any of these products are for illustrative purposes only. Philips Semiconductors make no representation or warranty that such applications will be suitable for the specified use without further testing or modification.

Disclaimers

Life support — These products are not designed for use in life support appliances, devices or systems where malfunction of these products can reasonably be expected to result in personal injury. Philips Semiconductors customers using or selling these products for use in such applications do so at their own risk and agree to fully indemnify Philips Semiconductors for any damages resulting from such application.

Right to make changes — Philips Semiconductors reserves the right to make changes, without notice, in the products, including circuits, standard cells, and/or software, described or contained herein in order to improve design and/or performance. Philips Semiconductors assumes no responsibility or liability for the use of any of these products, conveys no license or title under any patent, copyright, or mask work right to these products, and makes no representations or warranties that these products are free from patent, copyright, or mask work right infringement, unless otherwise specified.

Philips Semiconductors
811 East Arques Avenue
P.O. Box 3409
Sunnyvale, California 94088-3409
Telephone 800-234-7381

© Copyright Philips Electronics North America Corporation 1998
All rights reserved. Printed in U.S.A.

print code

Date of release: 05-96

Document order number:

9397-750-04523

Let's make things better.