

DM74ALS240A • DM74ALS241A Octal 3-STATE Bus Driver

General Description

These octal 3-STATE bus drivers are designed to provide the designer with flexibility in implementing a bus interface with memory, microprocessor, or communication systems. The output 3-STATE gating control is organized into two separate groups of four buffers. The DM74ALS240A control inputs symmetrically enable the respective outputs when set logic LOW, while the DM74ALS241A has complementary enable gating. The 3-STATE circuitry contains a feature that maintains the buffer outputs in 3-STATE (high impedance state) during power supply ramp-up or ramp-down. This eliminates bus glitching problems that arise during power-up and power-down.

Features

- Advanced low power oxide-isolated ion-implanted Schottky TTL process
- Functional and pin compatible with the DM74LS counterpart
- Improved switching performance with less power dissipation compared with the DM74LS counterpart
- Switching response specified into 500Ω and 50 pF load
- Switching response specifications guaranteed over full temperature and V_{CC} supply range
- PNP input design reduces input loading
- Low level drive current: 74ALS = 24 mA

Ordering Code:

Order Number	Package Number	Package Description
DM74ALS240AWM	M20B	20-Lead Small Outline Integrated Circuit (SOIC), JEDEC MS-013, 0.300 Wide
DM74ALS240ASJ	M20D	20-Lead Small Outline Package (SOP), EIAJ TYPE II, 5.3mm Wide
DM74ALS240AN	N20A	20-Lead Plastic Dual-In-Line Package (PDIP), JEDEC MS-001, 0.300 Wide
DM74ALS241AWM	M20B	20-Lead Small Outline Integrated Circuit (SOIC), JEDEC MS-013, 0.300 Wide
DM74ALS241AN	N20A	20-Lead Plastic Dual-In-Line Package (PDIP), JEDEC MS-001, 0.300 Wide

Devices also available in Tape and Reel. Specify by appending the suffix letter "X" to the ordering code.

Connection Diagrams

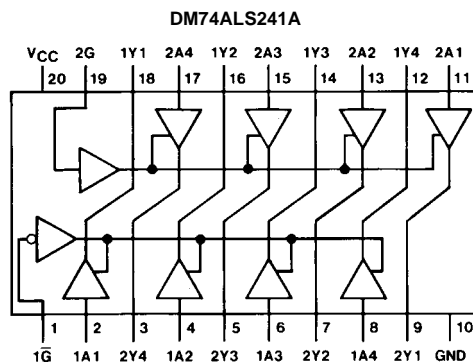
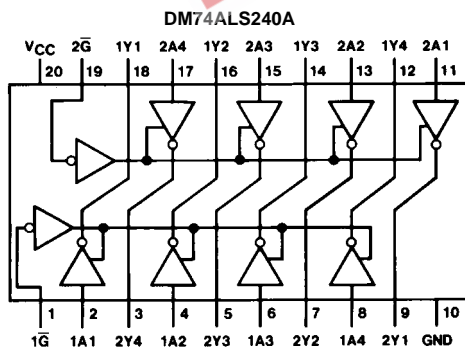

Function Tables

DM74ALS240A

Input		Output
\overline{G}	A	Y
L	L	H
L	H	L
H	X	Z

DM74ALS241A

Input		Output	Input		Output
$\overline{1G}$	1A	Y	2G	2A	Y
L	L	L	H	L	L
L	H	H	H	H	H
H	X	Z	L	X	Z

Logic Diagrams

DM74ALS240A

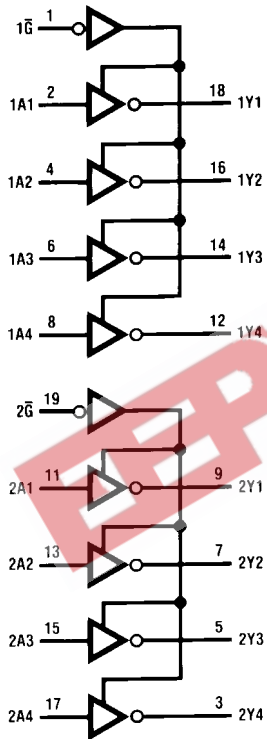

DM74ALS241A

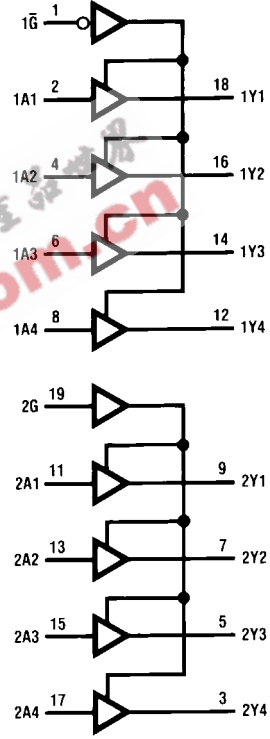

Absolute Maximum Ratings(Note 1)

Supply Voltage, V_{CC}	7V
Input Voltage	7V
Voltage Applied to Disabled Output	5.5V
Operating Free Air Temperature Range	0°C to +70°C
Storage Temperature Range	-65°C to +150°C
Typical θ_{JA}	
N Package	60.5°C/W
M Package	79.8°C/W

Note 1: The "Absolute Maximum Ratings" are those values beyond which the safety of the device cannot be guaranteed. The device should not be operated at these limits. The parametric values defined in the Electrical Characteristics tables are not guaranteed at the absolute maximum ratings. The "Recommended Operating Conditions" table will define the conditions for actual device operation.

Recommended Operating Conditions

Symbol	Parameter	Min	Typ	Max	Units
V_{CC}	Supply Voltage	4.5	5	5.5	V
V_{IH}	HIGH Level Input Voltage	2			V
V_{IL}	LOW Level Input Voltage			0.8	V
I_{OH}	HIGH Level Output Current			-15	mA
I_{OL}	LOW Level Output Current			24	mA
T_A	Operating Free Air Temperature	0		70	°C

Electrical Characteristics

over recommended operating free-air temperature range (unless otherwise specified)

Symbol	Parameter	Conditions	Min	Typ	Max	Units
V_{IK}	Input Clamp Voltage	$V_{CC} = 4.5V, I_I = -18\text{ mA}$			-1.5	V
V_{OH}	HIGH Level Output Voltage	$V_{CC} = 4.5V\text{ to }5.5V$	$I_{OH} = -0.4\text{ mA}$	$V_{CC} - 2$		V
		$V_{CC} = 4.5V$	$I_{OH} = -3\text{ mA}$	2.4		V
			$I_{OH} = \text{Max}$	2		V
V_{OL}	LOW Level Output Voltage	$V_{CC} = 4.5V$ $I_{OL} = \text{Max}$		0.35	0.5	V
I_I	Input Current at Max Input Voltage	$V_{CC} = 5.5V, V_I = 7V$			0.1	mA
I_{IH}	HIGH Level Input Current	$V_{CC} = 5.5V, V_I = 2.7V$			20	μA
I_{IL}	LOW Level Input Current	$V_{CC} = 5.5V, V_{IL} = 0.4V$			-0.1	mA
I_O	Output Drive Current	$V_{CC} = 5.5V, V_O = 2.25V$	-30		-112	mA
I_{OZH}	HIGH Level 3-STATE Output Current	$V_{CC} = 5.5V, V_O = 2.7V$			20	μA
I_{OZL}	LOW Level 3-STATE Output Current	$V_{CC} = 5.5V, V_O = 0.4V$			-20	μA
I_{CC}	Supply Current	$V_{CC} = 5.5V, \text{ALS240A}$		4	10	mA
		Outputs HIGH				
		Outputs LOW		13	23	mA
		Outputs 3-STATE		14	25	mA
		$V_{CC} = 5.5V, \text{ALS241A}$		9	15	mA
		Outputs HIGH				
Outputs LOW		15	26	mA		
Outputs 3-STATE		17	30	mA		

Switching Characteristics DM74ALS240A

over recommended operating free air temperature range

Symbol	Parameter	Conditions	From (Input)	To (Output)	Min	Max	Units
t_{PLH}	Propagation Delay Time LOW-to-HIGH Level Output	$V_{CC} = 4.5V$ to $5.5V$, $C_L = 50$ pF, $R1 = 500\Omega$, $R2 = 500\Omega$, $T_A = \text{Min to Max}$	A	Y	2	9	ns
t_{PHL}	Propagation Delay Time HIGH-to-LOW Level Output				2	9	ns
t_{PZH}	Output Enable Time to HIGH Level Output		\bar{G}	Y	3	13	ns
t_{PZL}	Output Enable Time to LOW Level Output		3		18	ns	
t_{PHZ}	Output Disable Time from HIGH Level Output		\bar{G}	Y	2	10	ns
t_{PLZ}	Output Disable Time from LOW Level Output				3	12	ns

Switching Characteristics DM74ALS241A

over recommended operating free air temperature range

Symbol	Parameter	Conditions	From (Input)	To (Output)	Min	Max	Units
t_{PLH}	Propagation Delay Time LOW-to-HIGH Level Output	$V_{CC} = 4.5V$ to $5.5V$, $C_L = 50$ pF, $R1 = 500\Omega$, $R2 = 500\Omega$, $T_A = \text{Min to Max}$	A	Y	3	11	ns
t_{PHL}	Propagation Delay Time HIGH-to-LOW Level Output				3	10	ns
t_{PZH}	Output Enable Time to HIGH Level Output		$1\bar{G}$	Y	3	21	ns
t_{PZL}	Output Enable Time to HIGH Level Output		3		21	ns	
t_{PHZ}	Output Disable Time to HIGH Level Output		$1\bar{G}$	Y	2	10	ns
t_{PLZ}	Output Disable Time to LOW Level Output				3	15	ns
t_{PZH}	Output Enable Time to HIGH Level Output		2G	Y	7	21	ns
t_{PZL}	Output Enable Time to LOW Level Output				7	21	ns
t_{PHZ}	Output Disable Time from HIGH Level Output		2G	Y	2	10	ns
t_{PLZ}	Output Disable Time from LOW Level Output				3	15	ns

Physical Dimensions inches (millimeters) unless otherwise noted

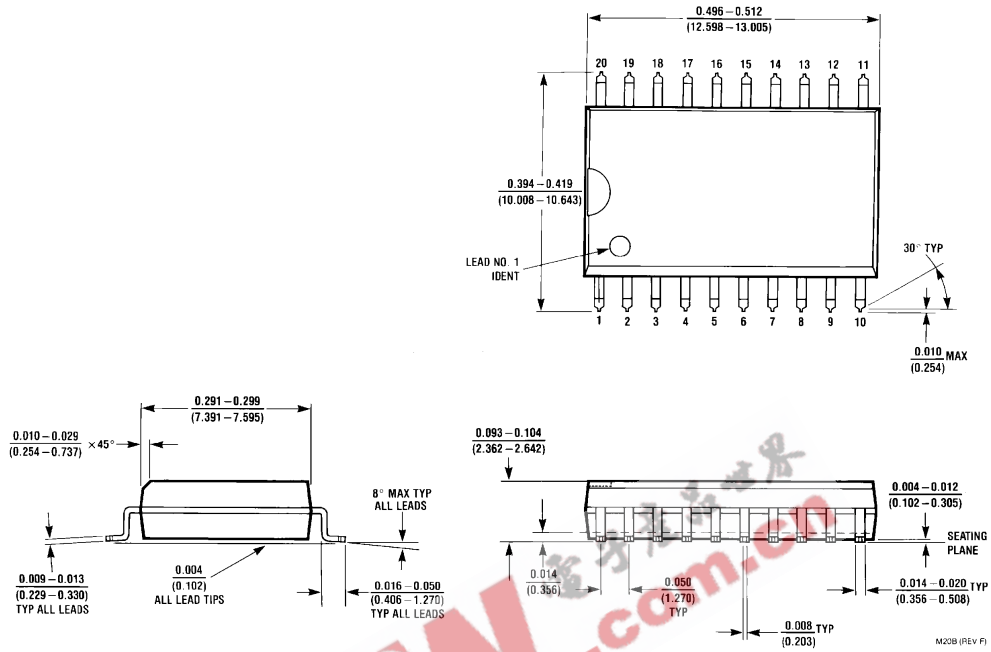

20-Lead Small Outline Integrated Circuit (SOIC), JEDEC MS-013, 0.300 Wide Package Number M20B

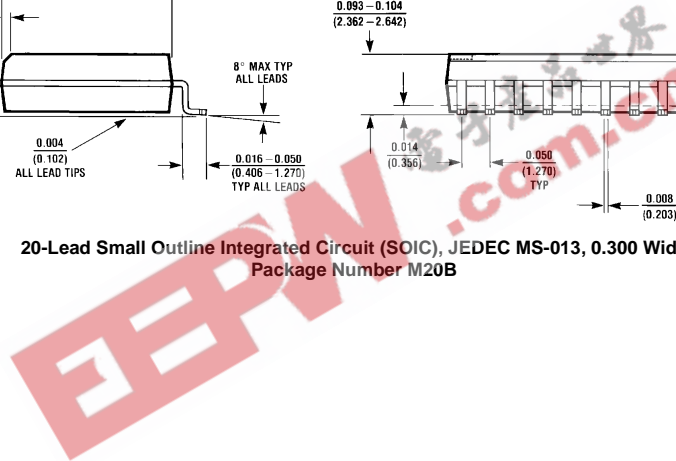

Physical Dimensions inches (millimeters) unless otherwise noted (Continued)

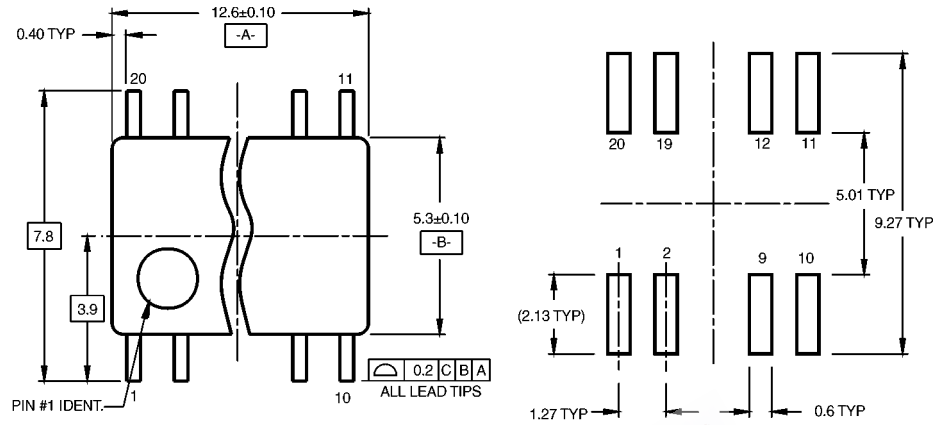

LAND PATTERN RECOMMENDATION

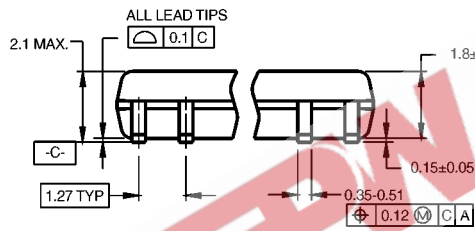

DIMENSIONS ARE IN MILLIMETERS

NOTES:

- A. CONFORMS TO EIAJ EDR-7320 REGISTRATION, ESTABLISHED IN DECEMBER, 1998.
- B. DIMENSIONS ARE IN MILLIMETERS.
- C. DIMENSIONS ARE EXCLUSIVE OF BURRS, MOLD FLASH, AND TIE BAR EXTRUSIONS.

M20DRevB1

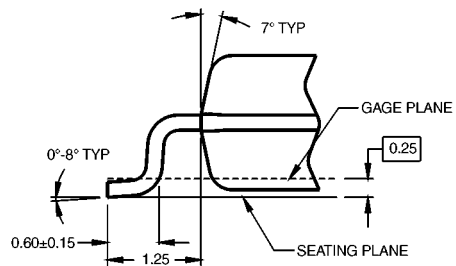

DETAIL A

**20-Lead Small Outline Package (SOP), EIAJ TYPE II, 5.3mm Wide
Package Number M20D**

