

CD4023BC Buffered Triple 3-Input NAND Gate

General Description

These triple gates are monolithic complementary MOS (CMOS) integrated circuits constructed with N- and P-channel enhancement mode transistors. They have equal source and sink current capabilities and conform to standard B series output drive. The devices also have buffered outputs which improve transfer characteristics by providing very high gain. All inputs are protected against static discharge with diodes to V_{DD} and V_{SS} .

Features

- Wide supply voltage range: 3.0V to 15V
- High noise immunity: $0.45 V_{DD}$ (typ)
- Low power TTL compatibility:
 - fan out of 2 driving 74L or 1 driving 74LS
- 5V–10V–15V parametric ratings
- Symmetrical output characteristics
- Maximum input leakage $1 \mu\text{A}$ at 15V over full temperature range

Ordering Code:

Order Number	Package Number	Package Description
CD4023BCM	M14A	14-Lead Small Outline Integrated Circuit (SOIC), JEDEC MS-120, 0.150 Narrow
CD4023BCS	M14D	14-Lead Small Outline Package (SOP), EIAJ TYPE II, 5.3mm Wide
CD4023BCN	N14A	14-Lead Plastic Dual-In-Line Package (PDIP), JEDEC MS-001, 0.300 Wide

Devices also available in Tape and Reel. Specify by appending the suffix letter "X" to the ordering code.

Connection Diagram

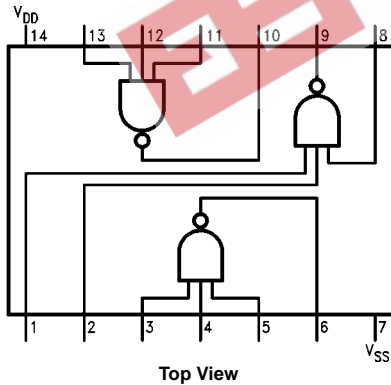

Block Diagram

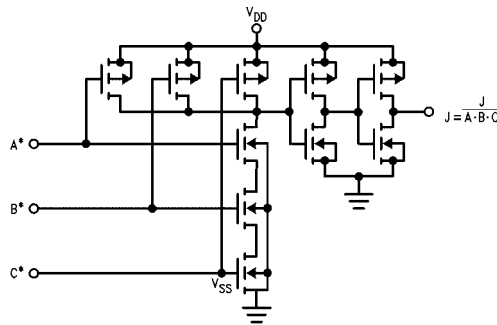

$1/3$ Device Shown

*All Inputs Protected by Standard CMOS Input Protection Circuit.

Absolute Maximum Ratings (Note 1)

(Note 2)

DC Supply Voltage (V_{DD})	-0.5 V_{DC} to +18 V_{DC}
Input Voltage (V_{IN})	-0.5 V_{DC} to $V_{DD}+0.5 V_{DC}$
Storage Temp. Range (T_S)	-65°C to +150°C
Power Dissipation (P_D)	
Dual-In-Line	700 mW
Small Outline	500 mW
Lead Temperature (T_L)	
(Soldering, 10 seconds)	260°C

Recommended Operating Conditions

DC Supply Voltage (V_{DD})	5 V_{DC} to 15 V_{DC}
Input Voltage (V_{IN})	0 V_{DC} to $V_{DD} V_{DC}$
Operating Temperature Range (T_A)	-40°C to +85°C

Note 1: "Absolute Maximum Ratings" are those values beyond which the safety of the device cannot be guaranteed; they are not meant to imply that the devices should be operated at these limits. The table of "Recommended Operating Conditions" and "Electrical Characteristics" provides conditions for actual device operation.

Note 2: $V_{SS} = 0V$ unless otherwise specified.

DC Electrical Characteristics (Note 3)

Symbol	Parameter	Conditions	-40°C		+25°C			+85°C		Units
			Min	Typ	Min	Typ	Max	Min	Max	
I_{DD}	Quiescent Device Current	$V_{DD} = 5V$		1.0		0.004	1.0		7.5	μA
		$V_{DD} = 10V$		2.0		0.005	2.0		15	
		$V_{DD} = 15V$		4.0		0.006	4.0		30	
V_{OL}	LOW Level Output Voltage	$V_{DD} = 5V$		0.05		0	0.05		0.05	V
		$V_{DD} = 10V$		0.05		0	0.05		0.05	
		$V_{DD} = 15V$		0.05		0	0.05		0.05	
V_{OH}	HIGH Level Output Voltage	$V_{DD} = 5V$	4.95		4.95	5		4.95		V
		$V_{DD} = 10V$	9.95		9.95	10		9.95		
		$V_{DD} = 15V$	14.95		14.95	15		14.95		
V_{IL}	LOW Level Input Voltage	$V_{DD}=5V, V_O=4.5V$		1.5		2	1.5		1.5	V
		$V_{DD}=10V, V_O=9.0V$		3.0		4	3.0		3.0	
		$V_{DD}=15V, V_O=13.5V$		4.0		6	4.0		4.0	
V_{IH}	HIGH Level Input Voltage	$V_{DD}=5V, V_O=0.5V$	3.5		3.5	3		3.5		V
		$V_{DD}=10V, V_O=1.0V$	7.0		7.0	6		7.0		
		$V_{DD}=15V, V_O=1.5V$	11.0		11.0	9		11.0		
I_{OL}	LOW Level Output Current (Note 4)	$V_{DD}=5V, V_O = 0.4V$	0.52		0.44	0.88		0.36		mA
		$V_{DD} = 10V, V_O = 0.5V$	1.3		1.1	2.2		0.90		
		$V_{DD} = 15V, V_O = 1.5V$	3.6		3.0	8		2.4		
I_{OH}	HIGH Level Output Current (Note 4)	$V_{DD} = 5V, V_O = 4.6V$	-0.52		-0.44	-0.88		-0.36		mA
		$V_{DD} = 10V, V_O = 9.5V$	-1.3		-1.1	-2.2		-0.90		
		$V_{DD} = 15V, V_O = 13.5V$	-3.6		-3.0	-8		-2.4		
I_{IN}	Input Current	$V_{DD} = 15V, V_{IN} = 0V$		-0.3		-10 ⁻⁵	-0.3		-1.0	μA
		$V_{DD} = 15V, V_{IN} = 15V$		0.3		10 ⁻⁵	0.3		1.0	

Note 3: $V_{SS} = 0V$ unless otherwise specified.

Note 4: I_{OH} and I_{OL} are tested one output at a time.

AC Electrical Characteristics (Note 5) $T_A = 25^\circ\text{C}$, $C_L = 50\text{ pF}$, $R_L = 200\text{ k}$, unless otherwise specified

Symbol	Parameter	Conditions	Min	Typ	Max	Units
t_{PHL}	Propagation Delay, HIGH-to-LOW Level	$V_{DD} = 5\text{V}$ $V_{DD} = 10\text{V}$ $V_{DD} = 15\text{V}$		130 60 40	250 100 70	ns
t_{PLH}	Propagation Delay, LOW-to-HIGH Level	$V_{DD} = 5\text{V}$ $V_{DD} = 10\text{V}$ $V_{DD} = 15\text{V}$		110 50 35	250 100 70	ns
t_{THL} t_{TLH}	Transition Time	$V_{DD} = 5\text{V}$ $V_{DD} = 10\text{V}$ $V_{DD} = 15\text{V}$		90 50 40	200 100 80	ns
C_{IN}	Average Input Capacitance	Any Input		5	7.5	pF
C_{PD}	Power Dissipation Capacity (Note 6)	Any Gate		17		pF

Note 5: AC Parameters are guaranteed by DC correlated testing.**Note 6:** C_{PD} determines the no load AC power consumption of any CMOS device.

For complete explanation, see Family Characteristics Application Note AN-90.

EEPW 电子产品世界
.com.cn

CD4023BC

Physical Dimensions inches (millimeters) unless otherwise noted



14-Lead Small Outline Integrated Circuit (SOIC), JEDEC MS-120, 0.150 Narrow
Package Number M14A

Physical Dimensions inches (millimeters) unless otherwise noted (Continued)



DIMENSIONS ARE IN MILLIMETERS

NOTES:

- A. CONFORMS TO EIAJ EDR-7320 REGISTRATION, ESTABLISHED IN DECEMBER, 1998.
- B. DIMENSIONS ARE IN MILLIMETERS.
- C. DIMENSIONS ARE EXCLUSIVE OF BURRS, MOLD FLASH, AND TIE BAR EXTRUSIONS.

M14DRevB1

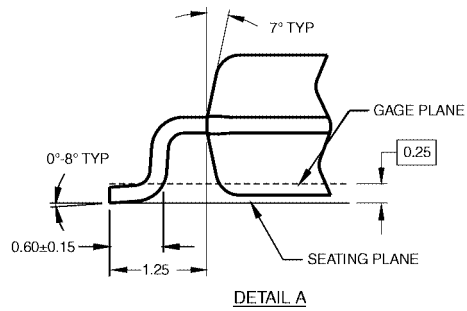

**14-Lead Small Outline Package (SOP), EIAJ TYPE II, 5.3mm Wide
Package Number M14D**

Physical Dimensions inches (millimeters) unless otherwise noted (Continued)

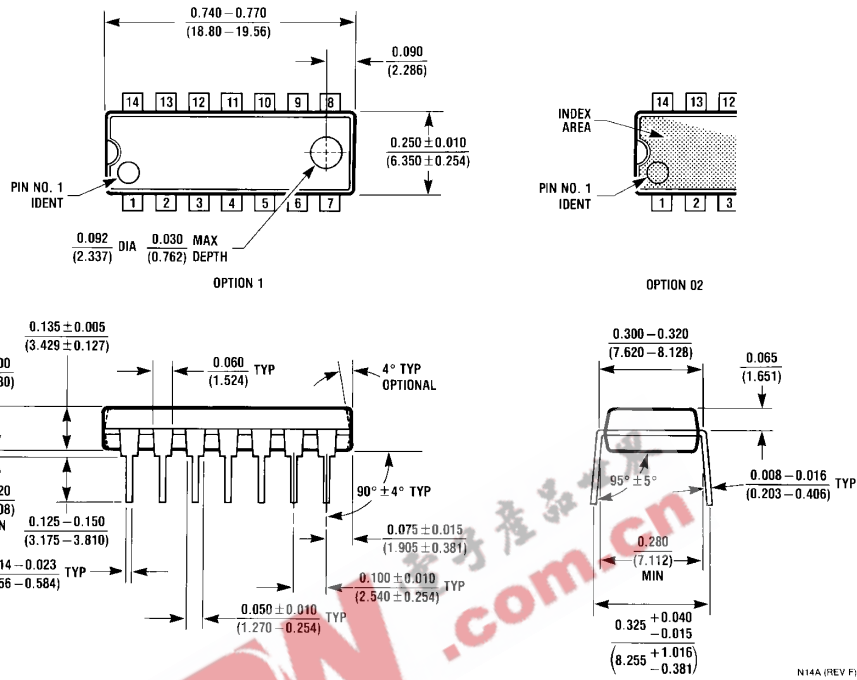

14-Lead Plastic Dual-In-Line Package (PDIP), JEDEC MS-001, 0.300 Wide Package Number N14A

Fairchild does not assume any responsibility for use of any circuitry described, no circuit patent licenses are implied and Fairchild reserves the right at any time without notice to change said circuitry and specifications.

LIFE SUPPORT POLICY

FAIRCHILD'S PRODUCTS ARE NOT AUTHORIZED FOR USE AS CRITICAL COMPONENTS IN LIFE SUPPORT DEVICES OR SYSTEMS WITHOUT THE EXPRESS WRITTEN APPROVAL OF THE PRESIDENT OF FAIRCHILD SEMICONDUCTOR CORPORATION. As used herein:

1. Life support devices or systems are devices or systems which, (a) are intended for surgical implant into the body, or (b) support or sustain life, and (c) whose failure to perform when properly used in accordance with instructions for use provided in the labeling, can be reasonably expected to result in a significant injury to the user.
2. A critical component in any component of a life support device or system whose failure to perform can be reasonably expected to cause the failure of the life support device or system, or to affect its safety or effectiveness.

www.fairchildsemi.com