

## DM74LS373 • DM74LS374

### 3-STATE Octal D-Type Transparent Latches and Edge-Triggered Flip-Flops

#### General Description

These 8-bit registers feature totem-pole 3-STATE outputs designed specifically for driving highly-capacitive or relatively low-impedance loads. The high-impedance state and increased high-logic level drive provide these registers with the capability of being connected directly to and driving the bus lines in a bus-organized system without need for interface or pull-up components. They are particularly attractive for implementing buffer registers, I/O ports, bidirectional bus drivers, and working registers.

The eight latches of the DM74LS373 are transparent D-type latches meaning that while the enable (G) is HIGH the Q outputs will follow the data (D) inputs. When the enable is taken LOW the output will be latched at the level of the data that was set up.

The eight flip-flops of the DM74LS374 are edge-triggered D-type flip flops. On the positive transition of the clock, the Q outputs will be set to the logic states that were set up at the D inputs.

A buffered output control input can be used to place the eight outputs in either a normal logic state (HIGH or LOW logic levels) or a high-impedance state. In the high-impedance state the outputs neither load nor drive the bus lines significantly.

The output control does not affect the internal operation of the latches or flip-flops. That is, the old data can be retained or new data can be entered even while the outputs are OFF.

#### Features

- Choice of 8 latches or 8 D-type flip-flops in a single package
- 3-STATE bus-driving outputs
- Full parallel-access for loading
- Buffered control inputs
- P-N-P inputs reduce D-C loading on data lines

#### Ordering Code:

| Order Number | Package Number | Package Description   |
|--------------|----------------|---|
| DM74LS373WM  | M20B           | 20-Lead Small Outline Integrated Circuit (SOIC), JEDEC MS-013, 0.300 Wide |
| DM74LS373SJ  | M20D           | 20-Lead Small Outline Package (SOP), EIAJ TYPE II, 5.3mm Wide             |
| DM74LS373N   | N20A           | 20-Lead Plastic Dual-In-Line Package (PDIP), JEDEC MS-001, 0.300 Wide     |
| DM74LS374WM  | M20B           | 20-Lead Small Outline Integrated Circuit (SOIC), JEDEC MS-013, 0.300 Wide |
| DM74LS374SJ  | M20D           | 20-Lead Small Outline Package (SOP), EIAJ TYPE II, 5.3mm Wide             |
| IDM29901NC   | N20A           | 20-Lead Plastic Dual-In-Line Package (PDIP), JEDEC MS-001, 0.300 Wide     |

Devices also available in Tape and Reel. Specify by appending the suffix letter "X" to the ordering code.

## Connection Diagrams

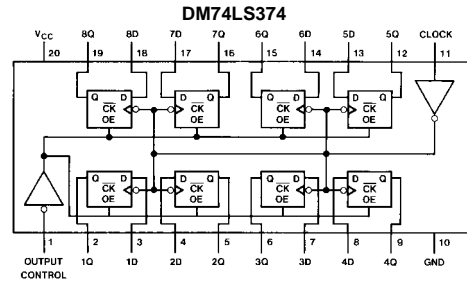
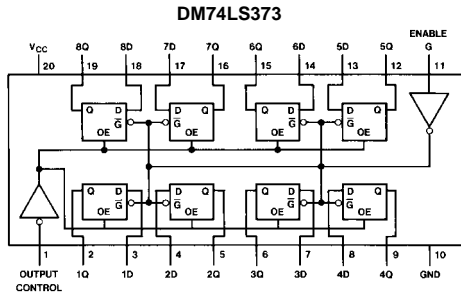

## Function Tables

DM74LS373

| Output Control | Enable G | D | Output         |
|----------------|----------|---|----------------|
| L              | H        | H | H              |
| L              | H        | L | L              |
| L              | L        | X | Q <sub>0</sub> |
| H              | X        | X | Z              |

DM74LS374

| Output Control | Clock | D | Output         |
|----------------|-------|---|----------------|
| L              | ↑     | H | H              |
| L              | ↑     | L | L              |
| L              | L     | X | Q <sub>0</sub> |
| H              | X     | X | Z              |

H = HIGH Level (Steady State) L = LOW Level (Steady State) X = Don't Care Z = High Impedance State  
 ↑ = Transition from LOW-to-HIGH level Q<sub>0</sub> = The level of the output before steady-state input conditions were established.

## Logic Diagrams

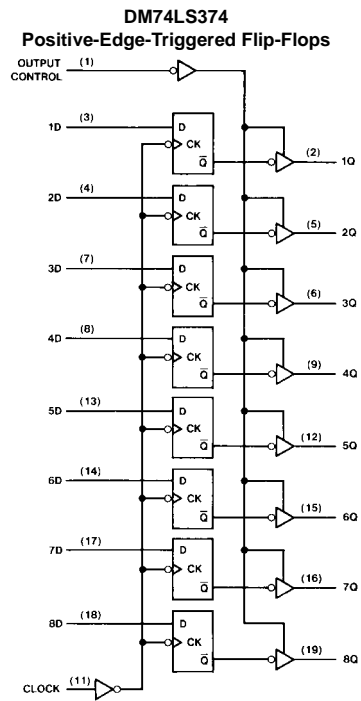
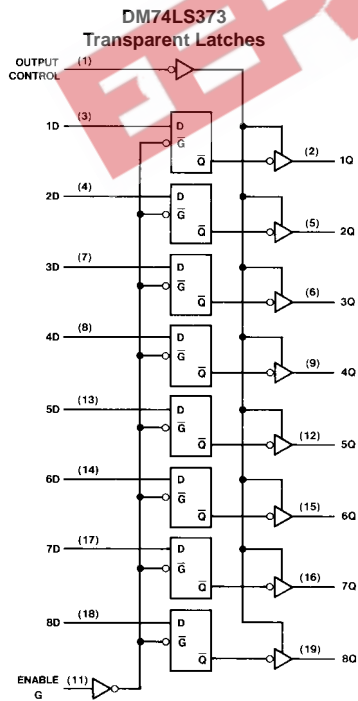

**Absolute Maximum Ratings**(Note 1)

|                                      |                 |
|--------------------------------------|-----------------|
| Supply Voltage                       | 7V              |
| Input Voltage                        | 7V              |
| Storage Temperature Range            | -65°C to +150°C |
| Operating Free Air Temperature Range | 0°C to +70°C    |

**Note 1:** The "Absolute Maximum Ratings" are those values beyond which the safety of the device cannot be guaranteed. The device should not be operated at these limits. The parametric values defined in the Electrical Characteristics tables are not guaranteed at the absolute maximum ratings. The "Recommended Operating Conditions" table will define the conditions for actual device operation.

**DM74LS373 Recommended Operating Conditions**

| Symbol   | Parameter                         | Min         | Nom | Max  | Units |
|----------|-----------------------------------|-------------|-----|------|-------|
| $V_{CC}$ | Supply Voltage                    | 4.75        | 5   | 5.25 | V     |
| $V_{IH}$ | HIGH Level Input Voltage          | 2           |     |      | V     |
| $V_{IL}$ | LOW Level Input Voltage           |             |     | 0.8  | V     |
| $I_{OH}$ | HIGH Level Output Current         |             |     | -2.6 | mA    |
| $I_{OL}$ | LOW Level Output Current          |             |     | 24   | mA    |
| $t_W$    | Pulse Width<br>(Note 3)           | Enable HIGH | 15  |      | ns    |
|          |                                   | Enable LOW  | 15  |      |       |
| $t_{SU}$ | Data Setup Time (Note 2) (Note 3) | 5↓          |     |      | ns    |
| $t_H$    | Data Hold Time (Note 2) (Note 3)  | 20↓         |     |      | ns    |
| $T_A$    | Free Air Operating Temperature    | 0           |     | 70   | °C    |

**Note 2:** The symbol (↓) indicates the falling edge of the clock pulse is used for reference.

**Note 3:**  $T_A = 25^\circ\text{C}$  and  $V_{CC} = 5\text{V}$ .

**DM74LS373 Electrical Characteristics**

over recommended operating free air temperature range (unless otherwise noted)

| Symbol    | Parameter  | Conditions   | Min | Typ<br>(Note 4) | Max  | Units |
|-----------|--|--|-----|-----------------|------|-------|
| $V_I$     | Input Clamp Voltage  | $V_{CC} = \text{Min}$ , $I_I = -18\text{ mA}$  |     |                 | -1.5 | V     |
| $V_{OH}$  | HIGH Level<br>Output Voltage                                       | $V_{CC} = \text{Min}$ , $I_{OH} = \text{Max}$  | 2.4 | 3.1             |      | V     |
|           |  | $V_{IL} = \text{Max}$ , $V_{IH} = \text{Min}$  |     |                 |      |       |
| $V_{OL}$  | LOW Level<br>Output Voltage  | $V_{CC} = \text{Min}$ , $I_{OL} = \text{Max}$  |     | 0.35            | 0.5  | V     |
|           |  | $V_{IL} = \text{Max}$ , $V_{IH} = \text{Min}$  |     |                 |      |       |
|           |  | $I_{OL} = 12\text{ mA}$ , $V_{CC} = \text{Min}$  |     |                 | 0.4  |       |
| $I_I$     | Input Current @ Max Input Voltage                                  | $V_{CC} = \text{Max}$ , $V_I = 7\text{V}$  |     |                 | 0.1  | mA    |
| $I_{IH}$  | HIGH Level Input Current   | $V_{CC} = \text{Max}$ , $V_I = 2.7\text{V}$  |     |                 | 20   | μA    |
| $I_{IL}$  | LOW Level Input Current  | $V_{CC} = \text{Max}$ , $V_I = 0.4\text{V}$  |     |                 | -0.4 | mA    |
| $I_{OZH}$ | Off-State Output Current with<br>HIGH Level Output Voltage Applied | $V_{CC} = \text{Max}$ , $V_O = 2.7\text{V}$<br>$V_{IH} = \text{Min}$ , $V_{IL} = \text{Max}$ |     |                 | 20   | μA    |
| $I_{OZL}$ | Off-State Output Current with<br>LOW Level Output Voltage Applied  | $V_{CC} = \text{Max}$ , $V_O = 0.4\text{V}$<br>$V_{IH} = \text{Min}$ , $V_{IL} = \text{Max}$ |     |                 | -20  | μA    |
| $I_{OS}$  | Short Circuit Output Current                                       | $V_{CC} = \text{Max}$ (Note 5)   | -50 |                 | -225 | mA    |
| $I_{CC}$  | Supply Current   | $V_{CC} = \text{Max}$ , $OC = 4.5\text{V}$ ,<br>$D_n$ , Enable = GND                         |     | 24              | 40   | mA    |

**Note 4:** All typicals are at  $V_{CC} = 5\text{V}$ ,  $T_A = 25^\circ\text{C}$ .

**Note 5:** Not more than one output should be shorted at a time, and the duration should not exceed one second.

**DM74LS373 Switching Characteristics**at  $V_{CC} = 5V$  and  $T_A = 25^\circ C$ 

| Symbol    | Parameter  | From (Input)<br>To (Output) | $R_L = 667\Omega$    |     |                       |     | Units |
|-----------|--|-----------------------------|----------------------|-----|-----------------------|-----|-------|
|           |  |                             | $C_L = 45\text{ pF}$ |     | $C_L = 150\text{ pF}$ |     |       |
|           |  |                             | Min                  | Max | Min                   | Max |       |
| $t_{PLH}$ | Propagation Delay Time<br>LOW-to-HIGH Level Output     | Data to Q                   |                      | 18  |                       | 26  | ns    |
| $t_{PHL}$ | Propagation Delay Time<br>HIGH-to-LOW Level Output     | Data to Q                   |                      | 18  |                       | 27  | ns    |
| $t_{PLH}$ | Propagation Delay Time<br>LOW-to-HIGH Level Output     | Enable to Q                 |                      | 30  |                       | 38  | ns    |
| $t_{PHL}$ | Propagation Delay Time<br>HIGH-to-LOW Level Output     | Enable to Q                 |                      | 30  |                       | 36  | ns    |
| $t_{PZH}$ | Output Enable Time<br>to HIGH Level Output             | Output Control to Any Q     |                      | 28  |                       | 36  | ns    |
| $t_{PZL}$ | Output Enable Time<br>to LOW Level Output              | Output Control to Any Q     |                      | 36  |                       | 50  | ns    |
| $t_{PHZ}$ | Output Disable Time<br>from HIGH Level Output (Note 6) | Output Control to Any Q     |                      | 20  |                       |     | ns    |
| $t_{PLZ}$ | Output Disable Time<br>from LOW Level Output (Note 6)  | Output Control to Any Q     |                      | 25  |                       |     | ns    |

Note 6:  $C_L = 5\text{ pF}$ .**DM74LS374 Recommended Operating Conditions**

| Symbol   | Parameter                         | Min           | Nom | Max  | Units      |
|----------|-----------------------------------|---------------|-----|------|------------|
| $V_{CC}$ | Supply Voltage                    | 4.75          | 5   | 5.25 | V          |
| $V_{IH}$ | HIGH Level Input Voltage          | 2             |     |      | V          |
| $V_{IL}$ | LOW Level Input Voltage           |               |     | 0.8  | V          |
| $I_{OH}$ | HIGH Level Output Current         |               |     | -2.6 | mA         |
| $I_{OL}$ | LOW Level Output Current          |               |     | 24   | mA         |
| $t_w$    | Pulse Width<br>(Note 8)           | Clock HIGH    | 15  |      | ns         |
|          |                                   | Clock LOW     | 15  |      |            |
| $t_{SU}$ | Data Setup Time (Note 7) (Note 8) | 20 $\uparrow$ |     |      | ns         |
| $t_H$    | Data Hold Time (Note 7) (Note 8)  | 1 $\uparrow$  |     |      | ns         |
| $T_A$    | Free Air Operating Temperature    | 0             |     | 70   | $^\circ C$ |

Note 7: The symbol ( $\uparrow$ ) indicates the rising edge of the clock pulse is used for reference.Note 8:  $T_A = 25^\circ C$  and  $V_{CC} = 5V$ .

| DM74LS374 Electrical Characteristics   |  |   |     |                        |            |               |
|--|--|---|-----|------------------------|------------|---------------|
| over recommended operating free air temperature range (unless otherwise noted)                                       |  |   |     |                        |            |               |
| Symbol   | Parameter  | Conditions  | Min | Typ<br>(Note 9)        | Max        | Units         |
| $V_I$  | Input Clamp Voltage  | $V_{CC} = \text{Min}, I_I = -18 \text{ mA}$   |     |                        | -1.5       | V             |
| $V_{OH}$   | HIGH Level<br>Output Voltage                                       | $V_{CC} = \text{Min}, I_{OH} = \text{Max}$<br>$V_{IL} = \text{Max}, V_{IH} = \text{Min}$  | 2.4 | 3.1                    |            | V             |
| $V_{OL}$   | LOW Level<br>Output Voltage  | $V_{CC} = \text{Min}, I_{OL} = \text{Max}$<br>$V_{IL} = \text{Max}, V_{IH} = \text{Min}$<br>$I_{OL} = 12 \text{ mA}, V_{CC} = \text{Min}$ |     | 0.35<br>0.25           | 0.5<br>0.4 | V             |
| $I_I$  | Input Current @ Max Input Voltage                                  | $V_{CC} = \text{Max}, V_I = 7V$   |     |                        | 0.1        | mA            |
| $I_{IH}$   | HIGH Level Input Current   | $V_{CC} = \text{Max}, V_I = 2.7V$   |     |                        | 20         | $\mu\text{A}$ |
| $I_{IL}$   | LOW Level Input Current  | $V_{CC} = \text{Max}, V_I = 0.4V$   |     |                        | -0.4       | mA            |
| $I_{OZH}$  | Off-State Output Current with<br>HIGH Level Output Voltage Applied | $V_{CC} = \text{Max}, V_O = 2.7V$<br>$V_{IH} = \text{Min}, V_{IL} = \text{Max}$   |     |                        | 20         | $\mu\text{A}$ |
| $I_{OZL}$  | Off-State Output Current with<br>LOW Level Output Voltage Applied  | $V_{CC} = \text{Max}, V_O = 0.4V$<br>$V_{IH} = \text{Min}, V_{IL} = \text{Max}$   |     |                        | -20        | $\mu\text{A}$ |
| $I_{OS}$   | Short Circuit Output Current                                       | $V_{CC} = \text{Max}$ (Note 10)   | -50 |                        | -225       | mA            |
| $I_{CC}$   | Supply Current   | $V_{CC} = \text{Max}, D_n = \text{GND}, \text{OC} = 4.5V$   |     | 27                     | 45         | mA            |
| <b>Note 9:</b> All typicals are at $V_{CC} = 5V, T_A = 25^\circ\text{C}$ .   |  |   |     |                        |            |               |
| <b>Note 10:</b> Not more than one output should be shorted at a time, and the duration should not exceed one second. |  |   |     |                        |            |               |
| DM74LS374 Switching Characteristics  |  |   |     |                        |            |               |
| at $V_{CC} = 5V$ and $T_A = 25^\circ\text{C}$  |  |   |     |                        |            |               |
| Symbol   | Parameter  | $R_L = 667\Omega$   |     |                        |            | Units         |
|  |  | $C_L = 45 \text{ pF}$   |     | $C_L = 150 \text{ pF}$ |            |               |
|  |  | Min   | Max | Min                    | Max        |               |
| $f_{MAX}$  | Maximum Clock Frequency  | 35  |     | 20                     |            | MHz           |
| $t_{PLH}$  | Propagation Delay Time<br>LOW-to-HIGH Level Output                 |   | 28  |                        | 32         | ns            |
| $t_{PHL}$  | Propagation Delay Time<br>HIGH-to-LOW Level Output                 |   | 28  |                        | 38         | ns            |
| $t_{PZH}$  | Output Enable Time<br>to HIGH Level Output                         |   | 28  |                        | 44         | ns            |
| $t_{PZL}$  | Output Enable Time<br>to LOW Level Output                          |   | 28  |                        | 44         | ns            |
| $t_{PHZ}$  | Output Disable Time<br>from HIGH Level Output (Note 11)            |   | 20  |                        |            | ns            |
| $t_{PLZ}$  | Output Disable Time<br>from LOW Level Output (Note 11)             |   | 25  |                        |            | ns            |
| <b>Note 11:</b> $C_L = 5 \text{ pF}$ .   |  |   |     |                        |            |               |

**Physical Dimensions** inches (millimeters) unless otherwise noted

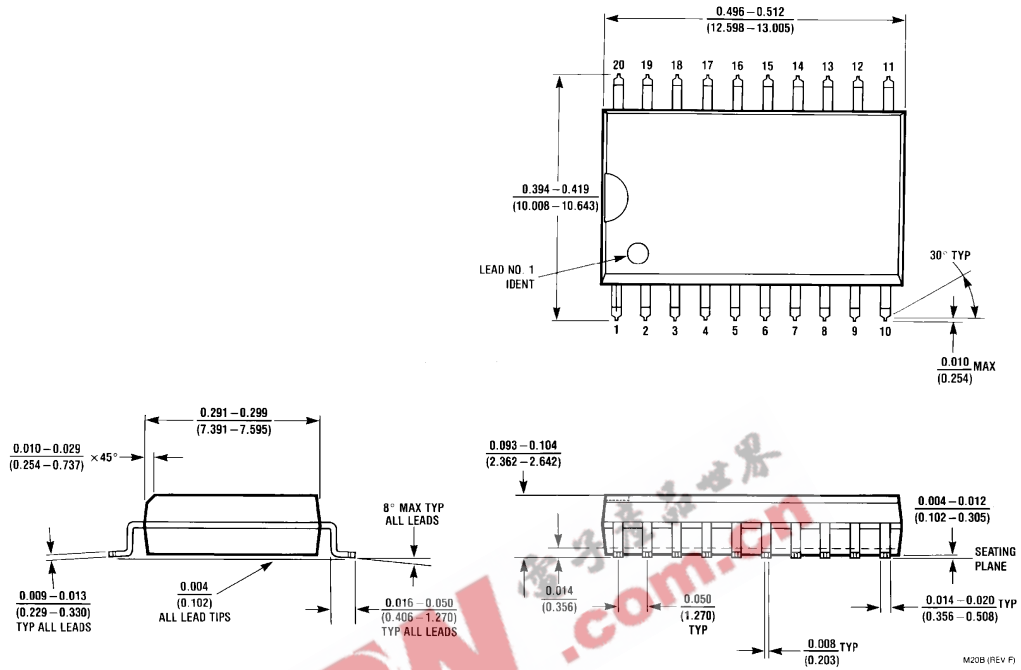

**20-Lead Small Outline Integrated Circuit (SOIC), JEDEC MS-013, 0.300 Wide  
Package Number M20B**

**Physical Dimensions** inches (millimeters) unless otherwise noted (Continued)

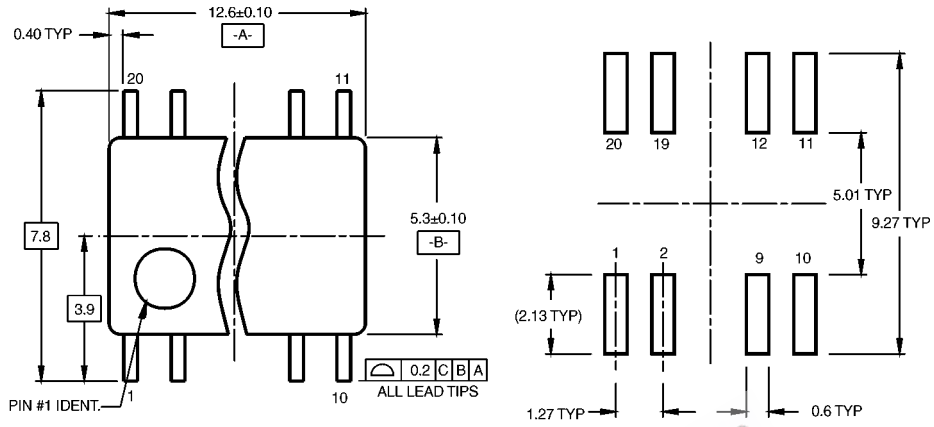

**LAND PATTERN RECOMMENDATION**

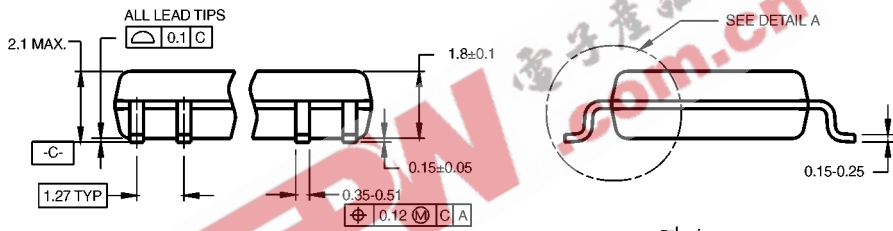

DIMENSIONS ARE IN MILLIMETERS

- NOTES:
- A. CONFORMS TO EIAJ EDR-7320 REGISTRATION, ESTABLISHED IN DECEMBER, 1998.
  - B. DIMENSIONS ARE IN MILLIMETERS.
  - C. DIMENSIONS ARE EXCLUSIVE OF BURRS, MOLD FLASH, AND TIE BAR EXTRUSIONS.

M20DRevB1

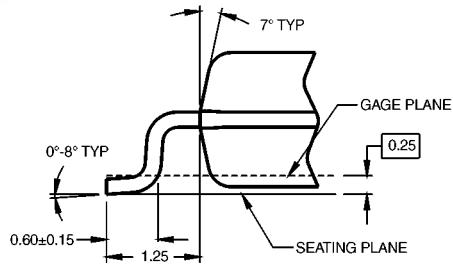

**DETAIL A**

**20-Lead Small Outline Package (SOP), EIAJ TYPE II, 5.3mm Wide Package Number M20D**

