



### GENERAL DESCRIPTION



The ICS843004I-04 is a 4 output LVPECL Synthesizer optimized to generate clock frequencies for a variety of high performance applications and is a member of the HiPerClocks™ family of high performance clock solutions from ICS. This device can select its input reference clock from either a crystal input or a single-ended clock signal. It can be configured to generate 4 outputs with individually selectable divide-by-one or divide-by-four function via the 4 frequency select pins (F\_SEL[3:0]). The ICS843004I-04 uses ICS' 3<sup>rd</sup> generation low phase noise VCO technology and can achieve 1ps or lower typical rms phase jitter. This ensures that it will easily meet clocking requirements for SDH (STM-1/STM-4/STM-16) and SONET (OC-3/OC12/OC-48). This device is suitable for multi-rate and multiple port line card applications. The ICS843004I-04 is conveniently packaged in a small 24-pin TSSOP package.

### FEATURES

- Four LVPECL outputs
- Selectable crystal oscillator interface or LVCMOS/LVTTL single-ended input
- Supports the following applications: SONET/SDH, SATA, or 10Gb Ethernet
- Output frequency range: 140MHz - 170MHz, 560MHz - 680MHz
- VCO range: 560MHz - 680MHz
- Crystal oscillator and CLK range: 17.5MHz - 21.25MHz
- RMS phase jitter @ 622.08MHz output, using a 19.44MHz crystal (12kHz - 20MHz): 0.82ps (typical)
- RMS phase jitter @ 156.25MHz output, using a 19.53125MHz crystal (1.875MHz - 20MHz): 0.57ps (typical)
- RMS phase jitter @ 155.52MHz output, using a 19.44MHz crystal (12kHz - 20MHz): 0.94ps (typical)
- Full 3.3V supply mode
- -40°C to 85°C ambient operating temperature
- Available in both standard and lead-free RoHS compliant packages

### BLOCK DIAGRAM

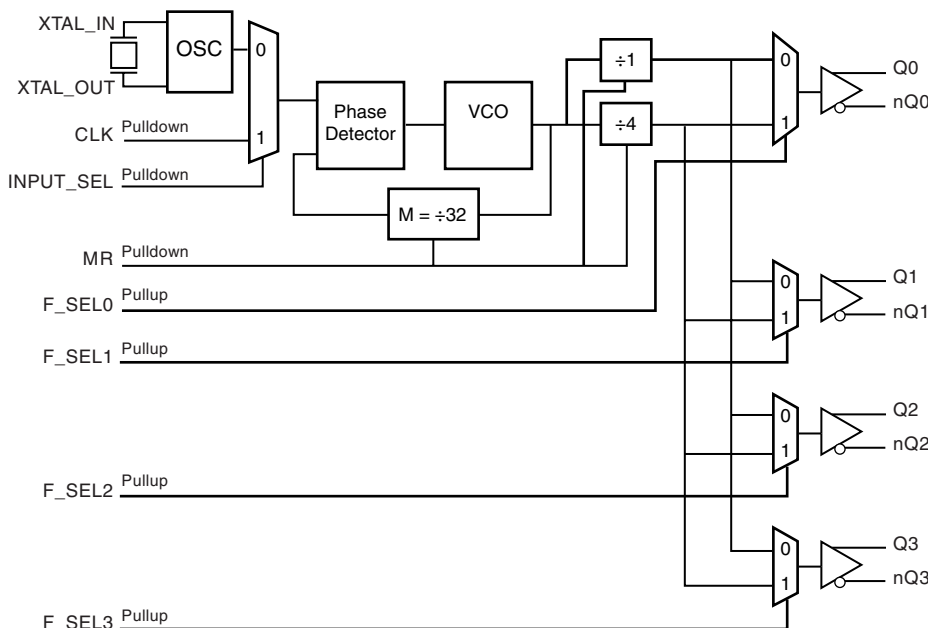

### PIN ASSIGNMENT

nQ1	1	24	nQ2
Q1	2	23	Q2
Vcco	3	22	Vcco
Q0	4	21	Q3
nQ0	5	20	nQ3
MR	6	19	VEE
F_SEL3	7	18	F_SEL2
nc	8	17	INPUT_SEL
VCCA	9	16	CLK
F_SEL0	10	15	VEE
Vcc	11	14	XTAL_IN
F_SEL1	12	13	XTAL_OUT

#### ICS843004I-04

#### 24-Lead TSSOP

4.40mm x 7.8mm x 0.92mm  
package body  
**G Package**  
Top View



**TABLE 1. PIN DESCRIPTIONS**

Number	Name	Type		Description
1, 2	nQ1, Q1	Output		Differential output pair. LVPECL interface levels.
3, 22	V <sub>CC0</sub>	Power		Output supply pins.
4, 5	Q0, nQ0	Output		Differential output pair. LVPECL interface levels.
6	MR	Input	Pulldown	Active HIGH Master Reset. When logic HIGH, the internal dividers are reset causing the true outputs Qx to go low and the inverted outputs nQx to go high. When logic LOW, the internal dividers and the outputs are enabled. LVCMOS/LVTTL interface levels.
7, 10, 12, 18	F_SEL3, F_SEL0, F_SEL1, F_SEL2	Input	Pullup	Frequency select pins. LVCMOS/LVTTL interface levels. See Table 3.
8	nc	Unused		No connect.
9	V <sub>CCA</sub>	Power		Analog supply pin.
11	V <sub>CC</sub>	Power		Core supply pin.
13, 14	XTAL_OUT, XTAL_IN	Input		Parallel resonant crystal interface. XTAL_OUT is the output, XTAL_IN is the input.
15, 19	V <sub>EE</sub>	Power		Negative supply pins.
16	CLK	Input	Pulldown	LVCMOS/LVTTL clock input.
17	INPUT_SEL	Input	Pulldown	Selects between crystal or CLK inputs as the the PLL Reference source. Selects XTAL inputs when LOW. Selects CLK when HIGH. LVCMOS/LVTTL interface levels.
20, 21	nQ3, Q3	Output		Differential output pair. LVPECL interface levels.
23, 24	Q2, nQ2	Output		Differential output pair. LVPECL interface levels.

NOTE: Pulldown and Pullup refer to internal input resistors. See Table 2, Pin Characteristics, for typical values.

**TABLE 2. PIN CHARACTERISTICS**

Symbol	Parameter	Test Conditions	Minimum	Typical	Maximum	Units
C <sub>IN</sub>	Input Capacitance			4		pF
R <sub>PULLDOWN</sub>	Input Pulldown Resistor			51		kΩ
R <sub>PULLUP</sub>	Input Pullup Resistor			51		kΩ

**TABLE 3. OUTPUT CONFIGURATION AND FREQUENCY RANGE FUNCTION TABLE**

Inputs		VCO (MHz)	Divider Value	Output Frequency (MHz)	Application
F_SELx	XTAL (MHz)			Q0/nQ0:Q3/nQ3	
0	19.44	622.08	÷1	622.08	SONET/SDH
1	19.44	622.08	÷4	155.52	
0	18.75	600	÷1	600	SATA
1	18.75	600	÷4	150	
0	19.53125	625	÷1	625	10 Gigabit Ethernet
1	19.53125	625	÷4	156.25	
0	20.141601	644.5312	÷1	644.5312	10 Gigabit Ethernet 66B/64B FEC
1	20.141601	644.5312	÷4	161.13	



### ABSOLUTE MAXIMUM RATINGS

Supply Voltage, $V_{CC}$	4.6V
Inputs, $V_I$	-0.5V to $V_{CC} + 0.5V$
Outputs, $I_O$	
Continuous Current	50mA
Surge Current	100mA
Package Thermal Impedance, $\theta_{JA}$	70°C/W (0 mps)
Storage Temperature, $T_{STG}$	-65°C to 150°C

NOTE: Stresses beyond those listed under Absolute Maximum Ratings may cause permanent damage to the device. These ratings are stress specifications only. Functional operation of product at these conditions or any conditions beyond those listed in the *DC Characteristics* or *AC Characteristics* is not implied. Exposure to absolute maximum rating conditions for extended periods may affect product reliability.

**TABLE 4A. POWER SUPPLY DC CHARACTERISTICS,  $V_{CC} = V_{CCA} = V_{CCO} = 3.3V \pm 5\%$ ,  $T_A = -40^\circ C$  TO  $85^\circ C$**

Symbol	Parameter	Test Conditions	Minimum	Typical	Maximum	Units
$V_{CC}$	Core Supply Voltage		3.135	3.3	3.465	V
$V_{CCA}$	Analog Supply Voltage		3.135	3.3	3.465	V
$V_{CCO}$	Output Supply Voltage		3.135	3.3	3.465	V
$I_{EE}$	Power Supply Current				120	mA
$I_{CCA}$	Analog Supply Current				10	mA
$I_{CCO}$	Output Supply Current				120	mA

**TABLE 4B. LVCMOS / LVTTTL DC CHARACTERISTICS,  $V_{CC} = V_{CCA} = V_{CCO} = 3.3V \pm 5\%$ ,  $T_A = -40^\circ C$  TO  $85^\circ C$**

Symbol	Parameter	Test Conditions	Minimum	Typical	Maximum	Units
$V_{IH}$	Input High Voltage		2		$V_{CC} + 0.3$	V
$V_{IL}$	Input Low Voltage		-0.3		0.8	V
$I_{IH}$	Input High Current	CLK, MR, INPUT_SEL	$V_{CC} = V_{IN} = 3.465$		150	$\mu A$
		F_SEL0:F_SEL3	$V_{CC} = V_{IN} = 3.465$		5	$\mu A$
$I_{IL}$	Input Low Current	CLK, MR, INPUT_SEL	$V_{CC} = 3.465V, V_{IN} = 0V$	-5		$\mu A$
		F_SEL0:F_SEL3	$V_{CC} = 3.465V, V_{IN} = 0V$	-150		$\mu A$

**TABLE 4C. LVPECL DC CHARACTERISTICS,  $V_{CC} = V_{CCA} = V_{CCO} = 3.3V \pm 5\%$ ,  $T_A = -40^\circ C$  TO  $85^\circ C$**

Symbol	Parameter	Test Conditions	Minimum	Typical	Maximum	Units
$V_{OH}$	Output High Voltage; NOTE 1		$V_{CCO} - 1.4$		$V_{CCO} - 0.9$	V
$V_{OL}$	Output Low Voltage; NOTE 1		$V_{CCO} - 2.0$		$V_{CCO} - 1.7$	V
$V_{SWING}$	Peak-to-Peak Output Voltage Swing		0.6		1.0	V

NOTE 1: Outputs terminated with  $50\Omega$  to  $V_{CCO} - 2V$ .



**TABLE 5. CRYSTAL CHARACTERISTICS**

Parameter	Test Conditions	Minimum	Typical	Maximum	Units
Mode of Oscillation		Fundamental			
Frequency		17.5		21.25	MHz
Equivalent Series Resistance (ESR)				50	$\Omega$
Shunt Capacitance				7	pF
Drive Level				1	mW

NOTE: Characterized using an 18pF parallel resonant crystal.

**TABLE 6. AC CHARACTERISTICS,  $V_{CC} = V_{CCA} = V_{CCO} = 3.3V \pm 5\%$ ,  $T_A = -40^\circ C$  TO  $85^\circ C$**

Symbol	Parameter	Test Conditions	Minimum	Typical	Maximum	Units
$f_{OUT}$	Output Frequency	Output Divider = $\div 1$	560		680	MHz
		Output Divider = $\div 4$	140		170	MHz
$t_{sk(o)}$	Output Skew; NOTE 1, 2, 3				75	ps
$f_{jit}(\emptyset)$	RMS Phase Jitter (Random); NOTE 4	155.52MHz, Integration Range: 12kHz - 20MHz		0.94		ps
		156.25MHz, Integration Range: 1.875MHz - 20MHz		0.57		ps
		622.08MHz, Integration Range: 12kHz - 20MHz		82		ps
$t_R / t_F$	Output Rise/Fall Time	20% to 80%	175		675	ps
odc	Output Duty Cycle	Output Divider = $\div 4$	48		52	%
		Output Divider = $\div 1$	40		60	%

NOTE 1: Defined as skew between outputs at the same supply voltages and with equal load conditions. Measured at  $V_{CCO}/2$ .

NOTE 2: This parameter is defined in accordance with JEDEC Standard 65.

NOTE 3: Output skew measurements taken with all outputs in the same divide configuration.

NOTE 4: Please refer to the Phase Noise Plot.



## PARAMETER MEASUREMENT INFORMATION

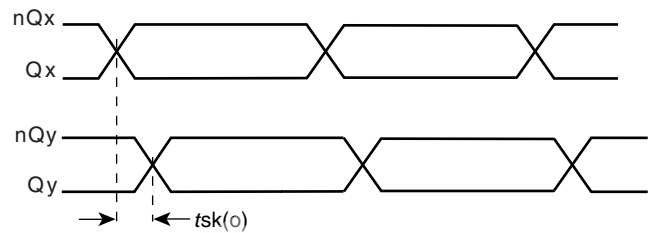
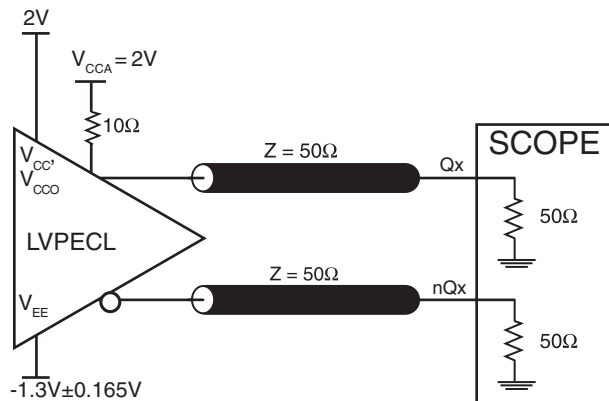

### 3.3V CORE/3.3V OUTPUT LOAD AC TEST CIRCUIT

### OUTPUT SKEW

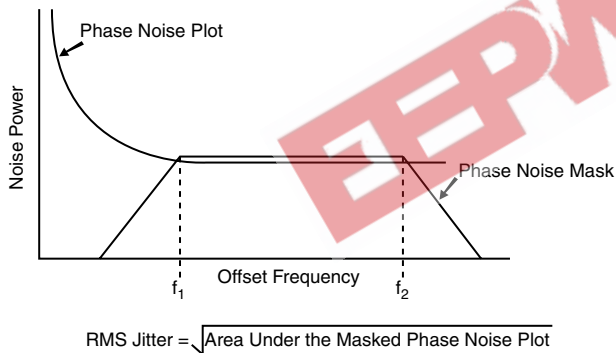

### RMS PHASE JITTER

### OUTPUT RISE/FALL TIME

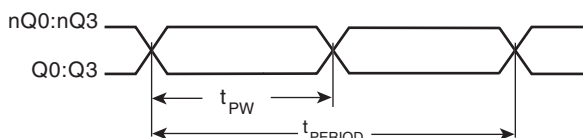

$$\text{odc} = \frac{t_{PW}}{t_{PERIOD}} \times 100\%$$

### OUTPUT DUTY CYCLE/PULSE WIDTH/PERIOD



## APPLICATION INFORMATION

### POWER SUPPLY FILTERING TECHNIQUES

As in any high speed analog circuitry, the power supply pins are vulnerable to random noise. The ICS843004I-04 provides separate power supplies to isolate any high switching noise from the outputs to the internal PLL.  $V_{CC}$ ,  $V_{CCA}$ , and  $V_{DDO}$  should be individually connected to the power supply plane through vias, and bypass capacitors should be used for each pin. To achieve optimum jitter performance, power supply isolation is required. *Figure 1* illustrates how a 10Ω resistor along with a 10μF and a .01μF bypass capacitor should be connected to each  $V_{CCA}$ .

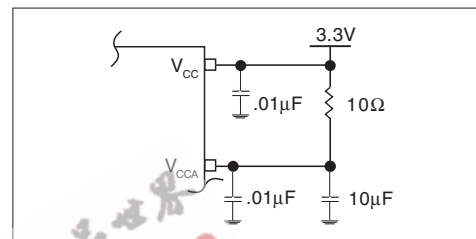

FIGURE 1. POWER SUPPLY FILTERING

### CRYSTAL INPUT INTERFACE

The ICS843004I-04 has been characterized with 18pF parallel resonant crystals. The capacitor values shown in *Figure 2* below were determined using a 19.44MHz,

18pF parallel resonant crystal and were chosen to minimize the ppm error.

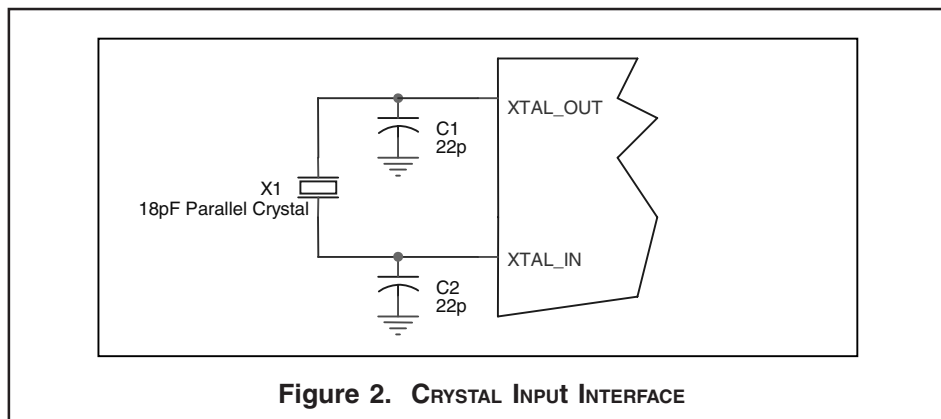

Figure 2. CRYSTAL INPUT INTERFACE



### LVCMOS TO XTAL INTERFACE

The XTAL\_IN input can accept a single-ended LVCMOS signal through an AC couple capacitor. A general interface diagram is shown in *Figure 3*. The XTAL\_OUT pin can be left floating. The input edge rate can be as slow as 10ns. For LVCMOS inputs, it is recommended that the amplitude be reduced from full swing to half swing in order to prevent signal interference with the power rail and to reduce noise. This configuration requires that the output

impedance of the driver ( $R_o$ ) plus the series resistance ( $R_s$ ) equals the transmission line impedance. In addition, matched termination at the crystal input will attenuate the signal in half. This can be done in one of two ways. First,  $R_1$  and  $R_2$  in parallel should equal the transmission line impedance. For most 50Ω applications,  $R_1$  and  $R_2$  can be 100Ω. This can also be accomplished by removing  $R_1$  and making  $R_2$  50Ω.

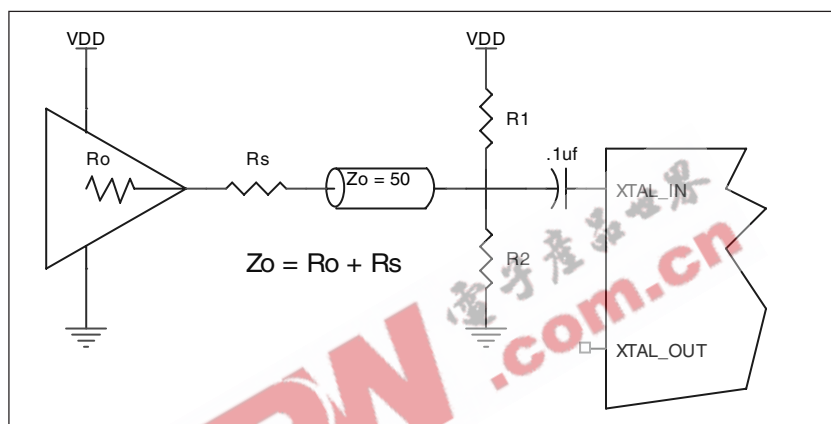

FIGURE 3. GENERAL DIAGRAM FOR LVCMOS DRIVER TO XTAL INPUT INTERFACE

### RECOMMENDATIONS FOR UNUSED INPUT AND OUTPUT PINS

#### INPUTS:

##### CRYSTAL INPUT:

For applications not requiring the use of the crystal oscillator input, both XTAL\_IN and XTAL\_OUT can be left floating. Though not required, but for additional protection, a 1kΩ resistor can be tied from XTAL\_IN to ground.

##### CLK INPUT:

For applications not requiring the use of a clock input, it can be left floating. Though not required, but for additional protection, a 1kΩ resistor can be tied from the CLK input to ground.

##### LVCMOS CONTROL PINS:

All control pins have internal pull-ups or pull-downs; additional resistance is not required but can be added for additional protection. A 1kΩ resistor can be used.

#### OUTPUTS:

##### LVPECL OUTPUT

All unused LVPECL outputs can be left floating. We recommend that there is no trace attached. Both sides of the differential output pair should either be left floating or terminated.



### TERMINATION FOR 3.3V LVPECL OUTPUT

The clock layout topology shown below is a typical termination for LVPECL outputs. The two different layouts mentioned are recommended only as guidelines.

FOUT and nFOUT are low impedance follower outputs that generate ECL/LVPECL compatible outputs. Therefore, terminating resistors (DC current path to ground) or current sources must be used for functionality. These outputs are designed to drive 50Ω transmission lines.

Matched impedance techniques should be used to maximize operating frequency and minimize signal distortion. *Figures 4A and 4B* show two different layouts which are recommended only as guidelines. Other suitable clock layouts may exist and it would be recommended that the board designers simulate to guarantee compatibility across all printed circuit and clock component process variations.

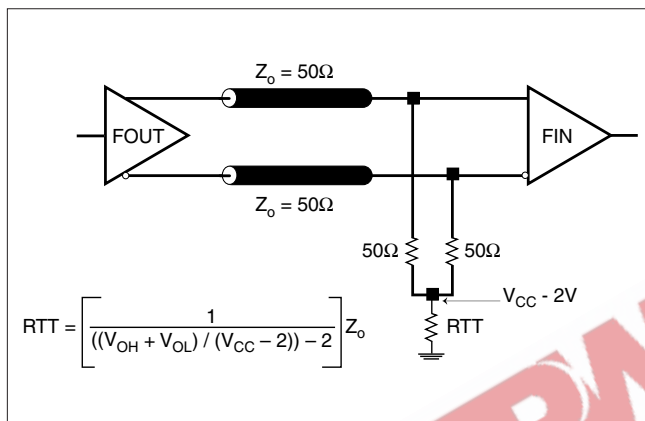

FIGURE 4A. LVPECL OUTPUT TERMINATION

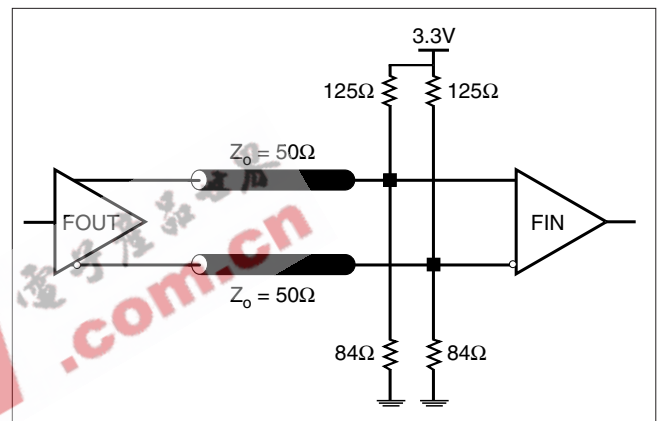

FIGURE 4B. LVPECL OUTPUT TERMINATION





## SCHEMATIC EXAMPLE

Figure 5 shows a schematic example for ICS843004I-04. In this example, the input is a 19.44MHz parallel resonant crystal with load capacitor CL=18pF. The 22pF frequency fine tuning capacitors are used C1 and C2. This example also shows general logic control input handling. For decoupling capacitors, it is

recommended to have one decouple capacitor per power pin. Each decoupling capacitor should be located as close as possible to the power pin. The low pass filter R2, C3 and C4 should also be located as close to the V<sub>CCA</sub> pin as possible.

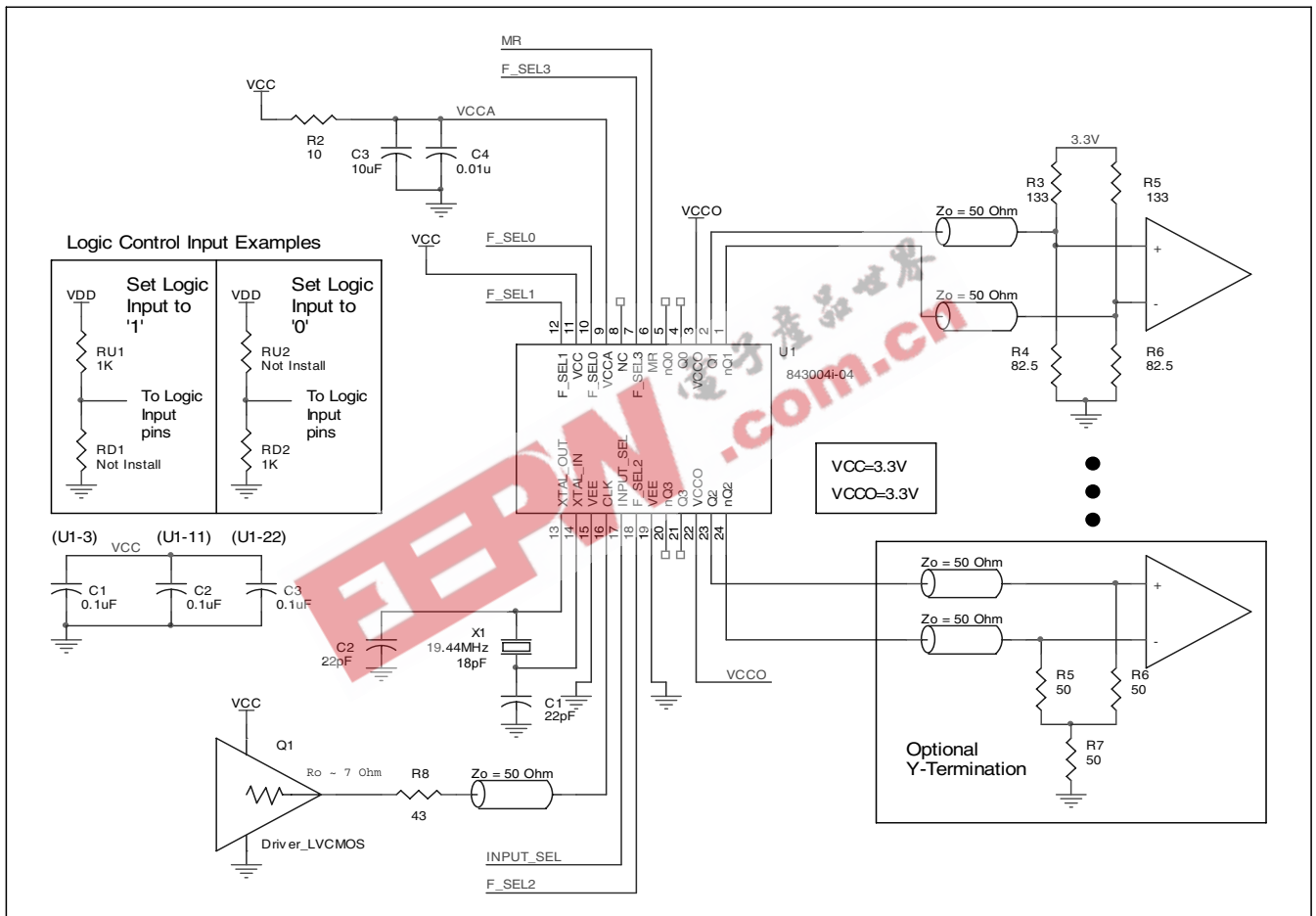

FIGURE 5. ICS844004I-04 SCHEMATIC EXAMPLE



## POWER CONSIDERATIONS

This section provides information on power dissipation and junction temperature for the ICS843004I-04. Equations and example calculations are also provided.

### 1. Power Dissipation.

The total power dissipation for the ICS843004I-04 is the sum of the core power plus the power dissipated in the load(s). The following is the power dissipation for  $V_{CC} = 3.3V + 5\% = 3.465V$ , which gives worst case results.

**NOTE:** Please refer to Section 3 for details on calculating power dissipated in the load.

- Power (core)<sub>MAX</sub> =  $V_{CC\_MAX} * I_{EE\_MAX} = 3.465V * 120mA = 415.8mW$
- Power (outputs)<sub>MAX</sub> = **30.2mW/Loaded Output pair**  
If all outputs are loaded, the total power is  $4 * 30mW = 120mW$

$$\text{Total Power}_{MAX} (3.465V, \text{ with all outputs switching}) = 415.8 + 120mW = 535.8mW$$

### 2. Junction Temperature.

Junction temperature,  $T_j$ , is the temperature at the junction of the bond wire and bond pad and directly affects the reliability of the device. The maximum recommended junction temperature for HiPerClockS™ devices is 125°C.

The equation for  $T_j$  is as follows:  $T_j = \theta_{JA} * Pd\_total + T_A$

$T_j$  = Junction Temperature

$\theta_{JA}$  = Junction-to-Ambient Thermal Resistance

$Pd\_total$  = Total Device Power Dissipation (example calculation is in section 1 above)

$T_A$  = Ambient Temperature

In order to calculate junction temperature, the appropriate junction-to-ambient thermal resistance  $\theta_{JA}$  must be used. Assuming an air flow of 1 meter per second and a multi-layer board, the appropriate value is 65°C/W per Table 7 below.

Therefore,  $T_j$  for an ambient temperature of 85°C with all outputs switching is:

$$85^\circ C + 0.536W * 65^\circ C/W = 119.8^\circ C. \text{ This is below the limit of } 125^\circ C.$$

This calculation is only an example.  $T_j$  will obviously vary depending on the number of loaded outputs, supply voltage, air flow, and the type of board (single layer or multi-layer).

**TABLE 7. THERMAL RESISTANCE  $\theta_{JA}$  FOR 24-LEAD TSSOP, FORCED CONVECTION**

$\theta_{JA}$ by Velocity (Meters per Second)			
	0	1	2.5
Multi-Layer PCB, JEDEC Standard Test Boards	70°C/W	65°C/W	62°C/W



### 3. Calculations and Equations.

The purpose of this section is to derive the power dissipated into the load.

LVPECL output driver circuit and termination are shown in the *Figure 6*.

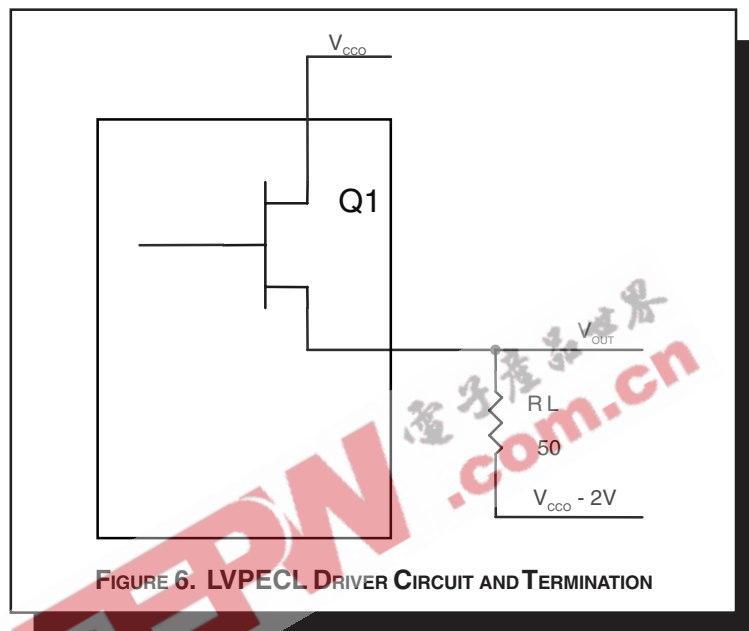

**FIGURE 6. LVPECL DRIVER CIRCUIT AND TERMINATION**

To calculate worst case power dissipation into the load, use the following equations which assume a 50Ω load, and a termination voltage of  $V_{CC} - 2V$ .

- For logic high,  $V_{OUT} = V_{OH\_MAX} = V_{CC\_MAX} - 0.9V$   
 $(V_{CC\_MAX} - V_{OH\_MAX}) = 0.9V$
- For logic low,  $V_{OUT} = V_{OL\_MAX} = V_{CC\_MAX} - 1.7V$   
 $(V_{CC\_MAX} - V_{OL\_MAX}) = 1.7V$

$Pd\_H$  is power dissipation when the output drives high.  
 $Pd\_L$  is the power dissipation when the output drives low.

$$Pd\_H = [(V_{OH\_MAX} - (V_{CC\_MAX} - 2V))/R_L] * (V_{CC\_MAX} - V_{OH\_MAX}) = [(2V - (V_{CC\_MAX} - V_{OH\_MAX}))/R_L] * (V_{CC\_MAX} - V_{OH\_MAX}) = [(2V - 0.9V)/50\Omega] * 0.9V = 19.8mW$$

$$Pd\_L = [(V_{OL\_MAX} - (V_{CC\_MAX} - 2V))/R_L] * (V_{CC\_MAX} - V_{OL\_MAX}) = [(2V - (V_{CC\_MAX} - V_{OL\_MAX}))/R_L] * (V_{CC\_MAX} - V_{OL\_MAX}) = [(2V - 1.7V)/50\Omega] * 1.7V = 10.2mW$$

Total Power Dissipation per output pair =  $Pd\_H + Pd\_L = 30mW$



Integrated  
Circuit  
Systems, Inc.

**ICS843004I-04**  
FEMTOCLOCKS™ CRYSTAL/LVCMOS-TO-  
3.3V LVPECL FREQUENCY SYNTHESIZER

## RELIABILITY INFORMATION

TABLE 8.  $\theta_{JA}$  VS. AIR FLOW TABLE FOR 24 LEAD TSSOP

$\theta_{JA}$ by Velocity (Meters per Second)			
	0	1	2.5
Multi-Layer PCB, JEDEC Standard Test Boards	70°C/W	65°C/W	62°C/W

### TRANSISTOR COUNT

The transistor count for ICS843004I-04 is: 2273

EEPW.com.cn 电子产品世界



Integrated  
Circuit  
Systems, Inc.

# ICS843004I-04

FEMTOCLOCKS™ CRYSTAL/LVCMOS-TO-  
3.3V LVPECL FREQUENCY SYNTHESIZER

## PACKAGE OUTLINE - G SUFFIX FOR 24 LEAD TSSOP

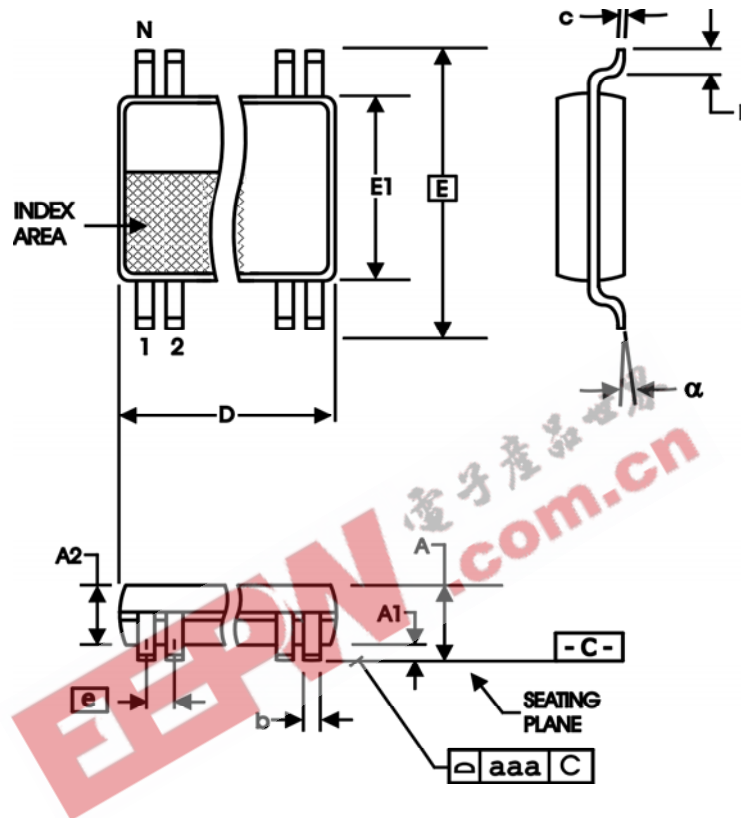

TABLE 9. PACKAGE DIMENSIONS

SYMBOL	Millimeters	
	Minimum	Maximum
N	24	
A	--	1.20
A1	0.05	0.15
A2	0.80	1.05
b	0.19	0.30
c	0.09	0.20
D	7.70	7.90
E	6.40 BASIC	
E1	4.30	4.50
e	0.65 BASIC	
L	0.45	0.75
α	0°	8°
aaa	--	0.10

Reference Document: JEDEC Publication 95, MO-153



Integrated  
Circuit  
Systems, Inc.

# ICS843004I-04

FEMTOCLOCKS™ CRYSTAL/LVCMOS-TO-  
3.3V LVPECL FREQUENCY SYNTHESIZER

TABLE 10. ORDERING INFORMATION

Part/Order Number	Marking	Package	Shipping Packaging	Temperature
ICS843004AGI-04	ICS843004AI04	24 Lead TSSOP	tube	-40°C to 85°C
ICS843004AGI-04T	ICS843004AI04	24 Lead TSSOP	2500 tape & reel	-40°C to 85°C
ICS843004AGI-04LF	ICS43004AI04L	24 Lead "Lead-Free" TSSOP	tube	-40°C to 85°C
ICS843004AGI-04LFT	ICS43004AI04L	24 Lead "Lead-Free" TSSOP	2500 tape & reel	-40°C to 85°C

NOTE: Parts that are ordered with an "LF" suffix to the part number are the Pb-Free configuration and are RoHS compliant.

EEPW 电子產品世界  
.com.cn

The aforementioned trademarks, HiPerClockS and FEMTOCLOCKS are trademarks of Integrated Circuit Systems, Inc. or its subsidiaries in the United States and/or other countries. While the information presented herein has been checked for both accuracy and reliability, Integrated Circuit Systems, Incorporated (ICS) assumes no responsibility for either its use or for infringement of any patents or other rights of third parties, which would result from its use. No other circuits, patents, or licenses are implied. This product is intended for use in normal commercial and industrial applications. Any other applications such as those requiring high reliability or other extraordinary environmental requirements are not recommended without additional processing by ICS. ICS reserves the right to change any circuitry or specifications without notice. ICS does not authorize or warrant any ICS product for use in life support devices or critical medical instruments.