



GENERAL DESCRIPTION

The ICS84321I is a general purpose, dual output Crystal-to-3.3V Differential LVPECL High Frequency Synthesizer and a member of the HiPerClockSM family of High Performance Clock Solutions from ICS. The ICS84321I has a selectable TEST_CLK or crystal inputs. The VCO operates at a frequency range of 620MHz to 780MHz. The VCO frequency is programmed in steps equal to the value of the input reference or crystal frequency. The VCO and output frequency can be programmed using the serial or parallel interfaces to the configuration logic. The low phase noise characteristics of the ICS84321I make it an ideal clock source for Fibre Channel 1, Fibre Channel 2, 10 Gigabit Fibre Channel, Gigabit Ethernet and 10 Gigabit Ethernet applications.

FEATURES

- Dual differential 3.3V LVPECL outputs
 - Selectable crystal oscillator interface or LVCMOS/LVTTL TEST_CLK
 - Output frequency range: 103.3MHz to 260MHz
 - Crystal input frequency range: 14MHz to 40MHz
 - VCO range: 620MHz to 780MHz
 - Parallel or serial interface for programming counter and output dividers
 - RMS period jitter: 3ps (typical)
 - RMS phase jitter at 155.52MHz, using a 38.88MHz crystal (12KHz to 20MHz): 2.5ps (typical)
- Phase noise: 155.52MHz
- | Offset | Noise Power |
|--------|---------------|
| 100Hz | -84.1 dBc/Hz |
| 1KHz | -109.8 dBc/Hz |
| 10KHz | -126.3 dBc/Hz |
| 100KHz | -128.7 dBc/Hz |
- 3.3V supply voltage
 - -40°C to 85°C ambient operating temperature

BLOCK DIAGRAM

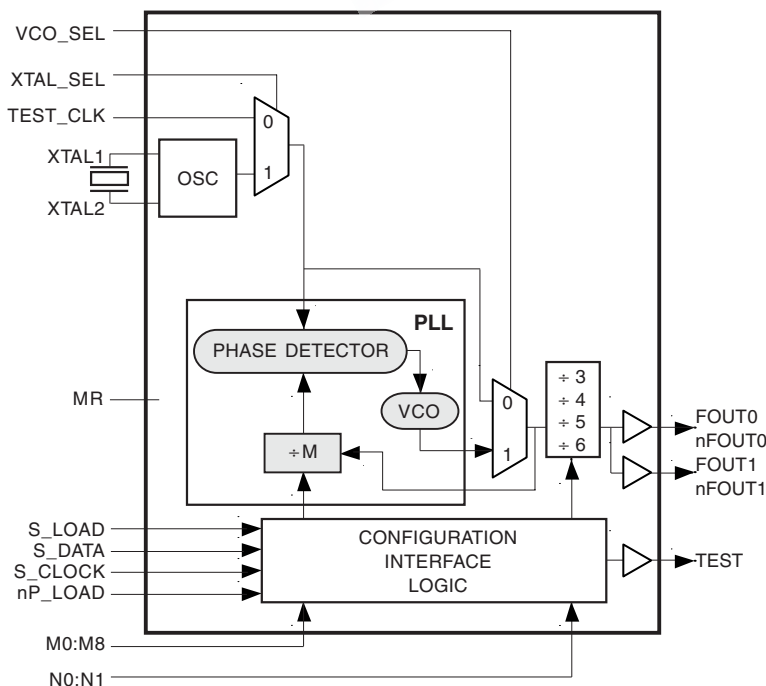

PIN ASSIGNMENT

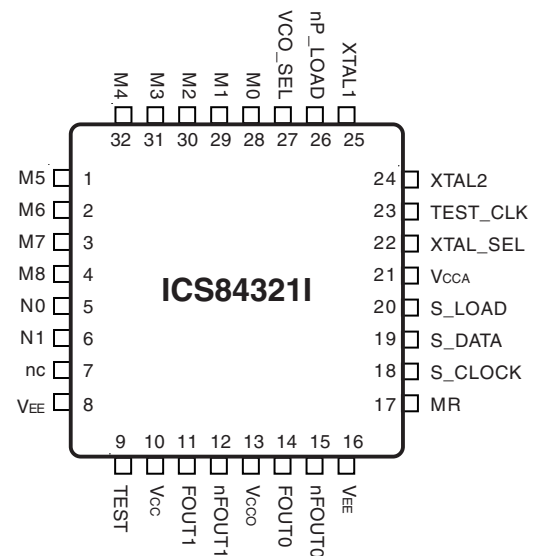

32-Lead LQFP
7mm x 7mm x 1.4mm package body
Y Package
Top View



FUNCTIONAL DESCRIPTION

NOTE: The functional description that follows describes operation using a 25MHz crystal. Valid PLL loop divider values for different crystal or input frequencies are defined in the Input Frequency Characteristics, Table 5, NOTE 1.

The ICS843211 features a fully integrated PLL and therefore requires no external components for setting the loop bandwidth. A fundamental crystal is used as the input to the on-chip oscillator. The output of the oscillator is fed into the phase detector. A 25MHz crystal provides a 25MHz phase detector reference frequency. The VCO of the PLL operates over a range of 620MHz to 780MHz. The output of the M divider is also applied to the phase detector.

The phase detector and the M divider force the VCO output frequency to be M times the reference frequency by adjusting the VCO control voltage. Note that for some values of M (either too high or too low), the PLL will not achieve lock. The output of the VCO is scaled by a divider prior to being sent to each of the LVPECL output buffers. The divider provides a 50% output duty cycle.

The programmable features of the ICS843211 support two input modes to program the M divider and N output divider. The two input operational modes are parallel and serial. Figure 1 shows the timing diagram for each mode. In parallel mode, the nP_LOAD input is initially LOW. The data on inputs M0 through M8 and N0 and N1 is passed directly to the M divider and N output divider. On the LOW-to-HIGH transition of the nP_LOAD input, the data is latched and the M divider remains loaded until the next LOW transition on nP_LOAD or until a serial event occurs. As a result, the M and N bits can be hardwired to set the M divider and N output divider to a spe-

cific default state that will automatically occur during power-up. The TEST output is LOW when operating in the parallel input mode. The relationship between the VCO frequency, the crystal frequency and the M divider is defined as follows:

$$f_{VCO} = f_{xtal} \times M$$

The M value and the required values of M0 through M8 are shown in Table 3B, Programmable VCO Frequency Function Table. Valid M values for which the PLL will achieve lock for a 25MHz reference are defined as $25 \leq M \leq 31$. The frequency output is defined as follows: $F_{OUT} = \frac{f_{VCO}}{N} = \frac{f_{xtal} \times M}{N}$

Serial operation occurs when nP_LOAD is HIGH and S_LOAD is LOW. The shift register is loaded by sampling the S_DATA bits with the rising edge of S_CLOCK. The contents of the shift register are loaded into the M divider and N output divider when S_LOAD transitions from LOW-to-HIGH. The M divide and N output divide values are latched on the HIGH-to-LOW transition of S_LOAD. If S_LOAD is held HIGH, data at the S_DATA input is passed directly to the M divider and N output divider on each rising edge of S_CLOCK. The serial mode can be used to program the M and N bits and test bits T1 and T0. The internal registers T0 and T1 determine the state of the TEST output as follows:

T1	T0	TEST Output
0	0	LOW
0	1	S_DATA, Shift Register Input
1	0	Output of M divider
1	1	CMOS Fout

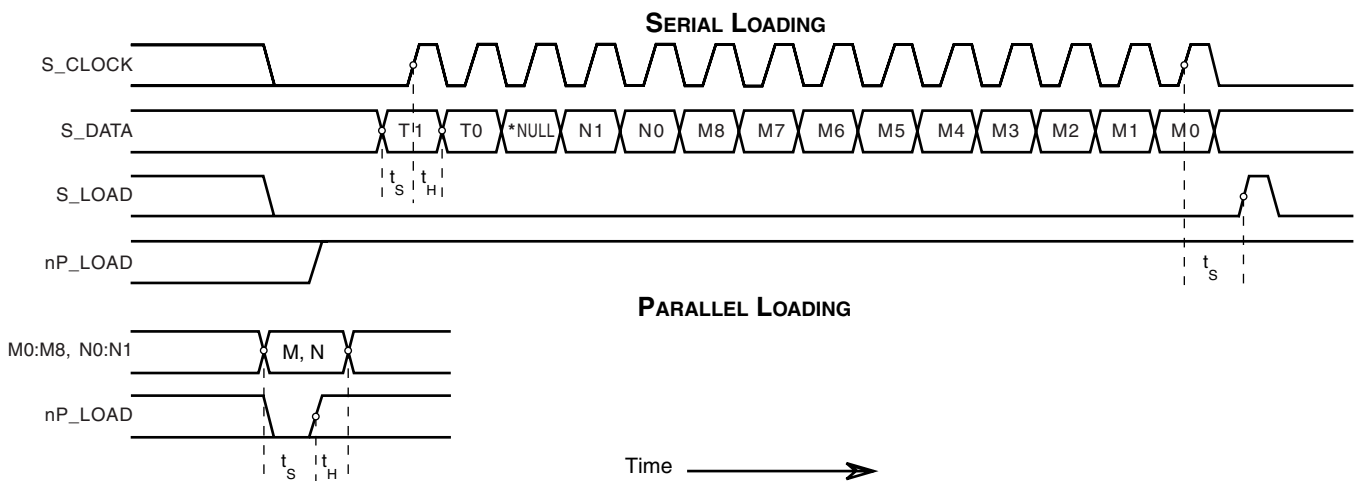

FIGURE 1. PARALLEL & SERIAL LOAD OPERATIONS

***NOTE:** The NULL timing slot must be observed.



TABLE 1. PIN DESCRIPTIONS

Number	Name	Type		Description
1	M5	Input	Pullup	M divider inputs. Data latched on LOW-to-HIGH transition of nP_LOAD input. LVCMOS / LVTTTL interface levels.
2, 3, 4, 28, 29, 30, 31, 32	M6, M7, M8, M0, M1, M2, M3, M4	Input	Pulldown	
5, 6	N0, N1	Input	Pulldown	
7	nc	Unused		
8, 16	V _{EE}	Power		Negative supply pins.
9	TEST	Output		Test output which is ACTIVE in the serial mode of operation. Output driven LOW in parallel mode. LVCMOS/LVTTTL interface levels.
10	V _{CC}	Power		Core supply pin.
11, 12	FOUT1, nFOUT1	Output		Differential output for the synthesizer. LVPECL interface levels.
13	V _{CCO}	Power		Output supply pin.
14, 15	FOUT0, nFOUT0	Output		Differential output for the synthesizer. LVPECL interface levels.
17	MR	Input	Pulldown	Active High Master Reset. When logic HIGH, the internal dividers are reset causing the true outputs FOUTx to go low, and the inverted outputs nFOUTx to go high. When logic LOW, the internal dividers and the outputs are enabled. Assertion of MR does not affect loaded M, N, and T values. LVCMOS / LVTTTL interface levels.
18	S_CLOCK	Input	Pulldown	Clocks in serial data present at S_DATA input into the shift register on the rising edge of S_CLOCK. LVCMOS / LVTTTL interface levels.
19	S_DATA	Input	Pulldown	Shift register serial input. Data sampled on the rising edge of S_CLOCK. LVCMOS/LVTTTL interface levels.
20	S_LOAD	Input	Pulldown	Controls transition of data from shift register into the dividers. LVCMOS / LVTTTL interface levels.
21	V _{CCA}	Power		Analog supply pin.
22	XTAL_SEL	Input	Pullup	Selects between crystal or test inputs as the PLL reference source. Selects XTAL inputs when HIGH. Selects TEST_CLK when LOW. LVCMOS / LVTTTL interface levels.
23	TEST_CLK	Input	Pulldown	Test clock input. LVCMOS / LVTTTL interface levels.
24, 25	XTAL2, XTAL1	Input		Crystal oscillator interface. XTAL1 is the input. XTAL2 is the output.
26	nP_LOAD	Input	Pulldown	Parallel load input. Determines when data present at M8:M0 is loaded into M divider, and when data present at N1:N0 sets the N output divider value. LVCMOS / LVTTTL interface levels.
27	VCO_SEL	Input	Pullup	Determines whether synthesizer is in PLL or bypass mode. LVCMOS / LVTTTL interface levels.

NOTE: Pullup and Pulldown refer to internal input resistors. See Table 2, Pin Characteristics, for typical values.

TABLE 2. PIN CHARACTERISTICS

Symbol	Parameter	Test Conditions	Minimum	Typical	Maximum	Units
C _{IN}	Input Capacitance			4		pF
R _{PULLUP}	Input Pullup Resistor			51		KΩ
R _{PULLDOWN}	Input Pulldown Resistor			51		KΩ



TABLE 3A. PARALLEL AND SERIAL MODE FUNCTION TABLE

Inputs							Conditions
MR	nP_LOAD	M	N	S_LOAD	S_CLOCK	S_DATA	
H	X	X	X	X	X	X	Reset. Forces outputs LOW.
L	L	Data	Data	X	X	X	Data on M and N inputs passed directly to the M divider and N output divider. TEST output forced LOW.
L	↑	Data	Data	L	X	X	Data is latched into input registers and remains loaded until next LOW transition or until a serial event occurs.
L	H	X	X	L	↑	Data	Serial input mode. Shift register is loaded with data on S_DATA on each rising edge of S_CLOCK.
L	H	X	X	↑	L	Data	Contents of the shift register are passed to the M divider and N output divider.
L	H	X	X	↓	L	Data	M divider and N output divider values are latched.
L	H	X	X	L	X	X	Parallel or serial input do not affect shift registers.
L	H	X	X	H	↑	Data	S_DATA passed directly to M divider as it is clocked.

NOTE: L = LOW
H = HIGH
X = Don't care
↑ = Rising edge transition
↓ = Falling edge transition

TABLE 3B. PROGRAMMABLE VCO FREQUENCY FUNCTION TABLE (NOTE 1)

VCO Frequency (MHz)	M Divide	256	128	64	32	16	8	4	2	1
		M8	M7	M6	M5	M4	M3	M2	M1	M0
625	25	0	0	0	0	1	1	0	0	1
650	26	0	0	0	0	1	1	0	1	0
675	27	0	0	0	0	1	1	0	1	1
•	•	•	•	•	•	•	•	•	•	•
775	31	0	0	0	0	1	1	1	1	1

NOTE 1: These M divide values and the resulting frequencies correspond to crystal or TEST_CLK input frequency of 25MHz.

TABLE 3C. PROGRAMMABLE OUTPUT DIVIDER FUNCTION TABLE

Inputs		N Divider Value	Output Frequency (MHz)	
N1	N0		Minimum	Maximum
0	0	3	206.7	260
0	1	4	155	195
1	0	5	124	156
1	1	6	103.3	130

TABLE 3D. COMMONLY USED CONFIGURATION FUNCTION TABLE

Crystal (MHz)	Input		Output Frequency (MHz)
	M Divider Value	N Divider Value	
19.44	32	4	155.52
19.53125	32	4	156.25
25	25	4	156.25
25	25	5	125
25.50	25	3	212.50
25.50	25	4	159.375
25.50	25	6	106.25
38.88	16	4	155.52



ABSOLUTE MAXIMUM RATINGS

Supply Voltage, V_{CC}	4.6V
Inputs, V_I	-0.5V to $V_{CC} + 0.5V$
Outputs, I_O	
Continuous Current	50mA
Surge Current	100mA
Package Thermal Impedance, θ_{JA}	47.9°C/W (0 lfpm)
Storage Temperature, T_{STG}	-65°C to 150°C

NOTE: Stresses beyond those listed under Absolute Maximum Ratings may cause permanent damage to the device. These ratings are stress specifications only. Functional operation of product at these conditions or any conditions beyond those listed in the *DC Characteristics* or *AC Characteristics* is not implied. Exposure to absolute maximum rating conditions for extended periods may affect product reliability.

TABLE 4A. POWER SUPPLY DC CHARACTERISTICS, $V_{CC} = V_{CCA} = V_{CCO} = 3.3V \pm 5\%$, $T_A = -40^\circ C$ TO $85^\circ C$

Symbol	Parameter	Test Conditions	Minimum	Typical	Maximum	Units
V_{CC}	Core Supply Voltage		3.135	3.3	3.465	V
V_{CCA}	Analog Supply Voltage		3.135	3.3	3.465	V
V_{CCO}	Output Supply Voltage		3.135	3.3	3.465	V
I_{EE}	Power Supply Current				180	mA
I_{CCA}	Analog Supply Current				30	mA

TABLE 4B. LVCMOS / LVTTTL DC CHARACTERISTICS, $V_{CC} = V_{CCA} = V_{CCO} = 3.3V \pm 5\%$, $T_A = -40^\circ C$ TO $85^\circ C$

Symbol	Parameter	Test Conditions	Minimum	Typical	Maximum	Units
V_{IH}	Input High Voltage	VCO_SEL, XTAL_SEL, MR, S_LOAD, nP_LOAD, N0:N1, S_DATA, S_CLOCK, M0:M8	2		$V_{CC} + 0.3$	V
		TEST_CLK	2		$V_{CC} + 0.3$	V
V_{IL}	Input Low Voltage	VCO_SEL, XTAL_SEL, MR, S_LOAD, nP_LOAD, N0:N1, S_DATA, S_CLOCK, M0:M8	-0.3		0.8	V
		TEST_CLK	-0.3		1.3	V
I_{IH}	Input High Current	M0-M4, M6-M8, N0, N1, MR, S_CLOCK, TEST_CLK, S_DATA, S_LOAD, nP_LOAD	$V_{CC} = V_{IN} = 3.465V$		150	μA
		M5, XTAL_SEL, VCO_SEL	$V_{CC} = V_{IN} = 3.465V$		5	μA
I_{IL}	Input Low Current	M0-M4, M6-M8, N0, N1, MR, S_CLOCK, TEST_CLK, S_DATA, S_LOAD, nP_LOAD	$V_{CC} = 3.465V,$ $V_{IN} = 0V$	-5		μA
		M5, XTAL_SEL, VCO_SEL	$V_{CC} = 3.465V,$ $V_{IN} = 0V$	-150		μA
V_{OH}	Output High Voltage	TEST; NOTE 1	2.6			V
V_{OL}	Output Low Voltage	TEST; NOTE 1			0.5	V

NOTE 1: Outputs terminated with 50 Ω to $V_{CCO}/2$.



TABLE 4C. LVPECL DC CHARACTERISTICS, $V_{CC} = V_{CCA} = V_{CCO} = 3.3V \pm 5\%$, $T_A = -40^\circ C$ TO $85^\circ C$

Symbol	Parameter	Test Conditions	Minimum	Typical	Maximum	Units
V_{OH}	Output High Voltage; NOTE 1		$V_{CCO} - 1.4$		$V_{CCO} - 1.0$	V
V_{OL}	Output Low Voltage; NOTE 1		$V_{CCO} - 2.0$		$V_{CCO} - 1.7$	V
V_{SWING}	Peak-to-Peak Output Voltage Swing		0.6		1.0	V

NOTE 1: Outputs terminated with 50Ω to $V_{CCO} - 2V$. See "Parameter Measurement Information" section, "3.3V Output Load Test Circuit".

TABLE 5. INPUT FREQUENCY CHARACTERISTICS, $V_{CC} = V_{CCA} = V_{CCO} = 3.3V \pm 5\%$, $T_A = -40^\circ C$ TO $85^\circ C$

Symbol	Parameter	Test Conditions	Minimum	Typical	Maximum	Units
f_{IN}	Input Frequency	TEST_CLK; NOTE 1	14		40	MHz
		XTAL1, XTAL2; NOTE 1	14		40	MHz
		S_CLOCK			50	MHz

NOTE 1: For the input crystal and TEST_CLK frequency range, the M value must be set for the VCO to operate within the 620MHz to 780MHz range. Using the minimum input frequency of 14MHz, valid values of M are $45 \leq M \leq 55$. Using the maximum frequency of 40MHz, valid values of M are $16 \leq M \leq 19$.

TABLE 6. CRYSTAL CHARACTERISTICS

Parameter	Test Conditions	Minimum	Typical	Maximum	Units
Mode of Oscillation		Fundamental			
Frequency		14		40	MHz
Equivalent Series Resistance (ESR)				50	Ω
Shunt Capacitance				7	pF

TABLE 7. AC CHARACTERISTICS, $V_{CC} = V_{CCA} = V_{CCO} = 3.3V \pm 5\%$, $T_A = -40^\circ C$ TO $85^\circ C$

Symbol	Parameter	Test Conditions	Minimum	Typical	Maximum	Units
F_{OUT}	Output Frequency		103.3		260	MHz
$f_{jit(per)}$	Period Jitter, RMS; NOTE 1			3	5	ps
$t_{sk(o)}$	Output Skew; NOTE 2, 3				15	ps
t_R / t_F	Output Rise/Fall Time	20% to 80%	200		700	ps
t_S	Setup Time	M, N to nP_LOAD	5			ns
		S_DATA to S_CLOCK	5			ns
		S_CLOCK to S_LOAD	5			ns
t_H	Hold Time	M, N to nP_LOAD	5			ns
		S_DATA to S_CLOCK	5			ns
		S_CLOCK to S_LOAD	5			ns
odc	Output Duty Cycle		45		55	%
t_{LOCK}	PLL Lock Time				1	ms

See Parameter Measurement Information section.

NOTE 1: Jitter performance using XTAL inputs.

NOTE 2: Defined as skew between outputs at the same supply voltage and with equal load conditions. Measured at the output differential cross points.

NOTE 3: This parameter is defined in accordance with JEDEC Standard 65.



TYPICAL PHASE NOISE

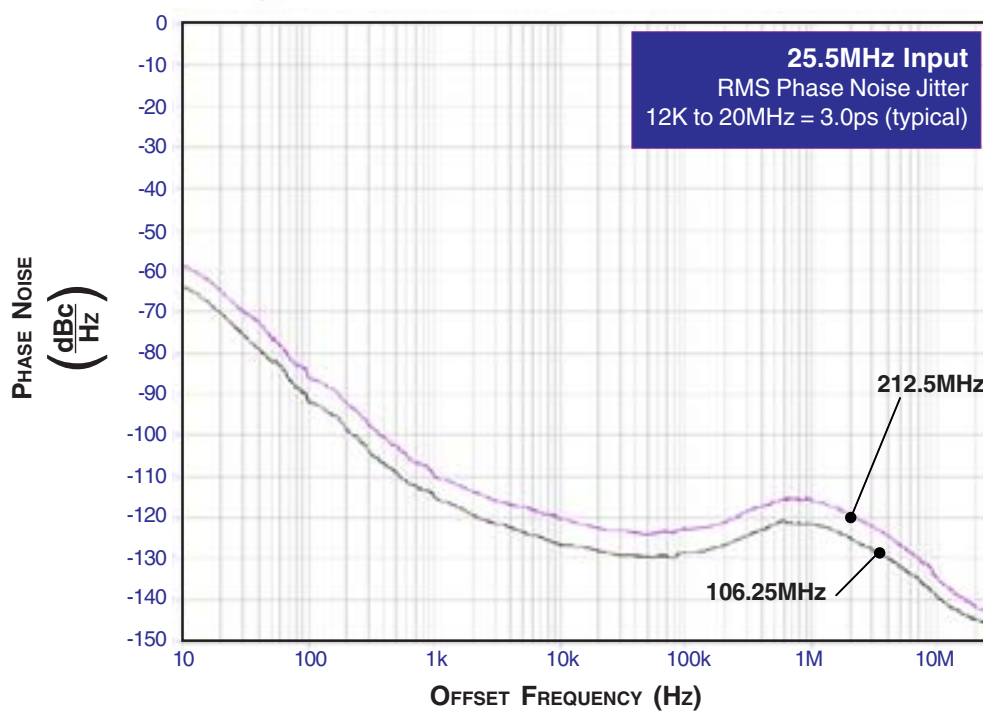
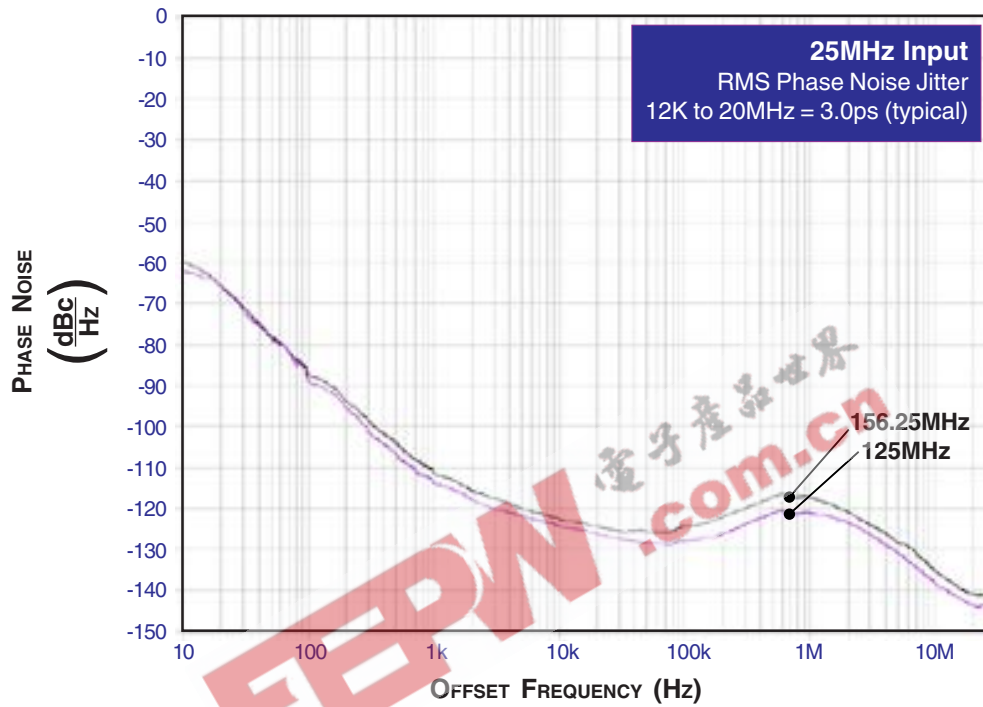



PARAMETER MEASUREMENT INFORMATION

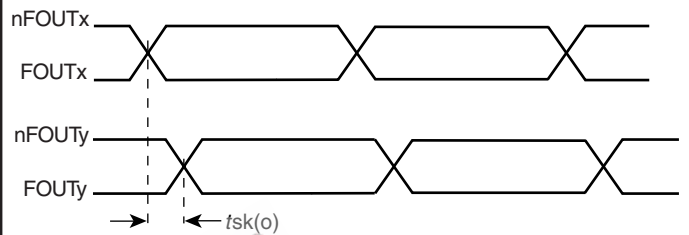
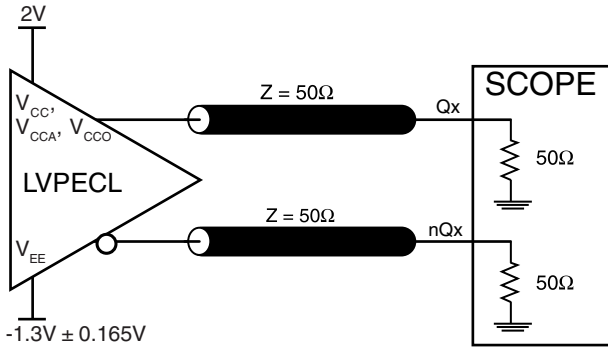

3.3V OUTPUT LOAD AC TEST CIRCUIT

OUTPUT SKEW

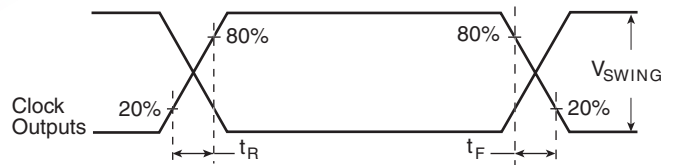
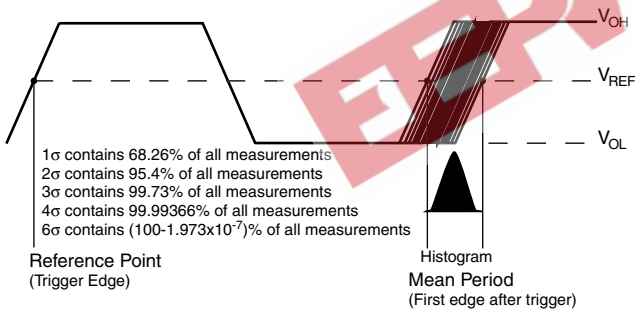

PERIOD JITTER

OUTPUT RISE/FALL TIME

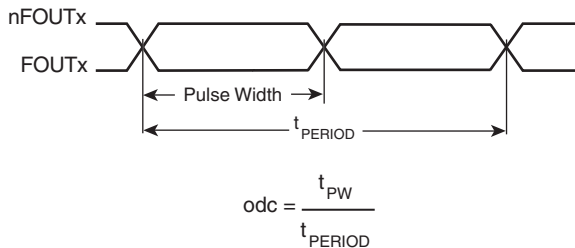

OUTPUT DUTY CYCLE/PULSE WIDTH/PERIOD



APPLICATION INFORMATION

TERMINATION FOR LVPECL OUTPUTS

The clock layout topology shown below is a typical termination for LVPECL outputs. The two different layouts mentioned are recommended only as guidelines.

FOUT and nFOUT are low impedance follower outputs that generate ECL/LVPECL compatible outputs. Therefore, terminating resistors (DC current path to ground) or current sources must be used for functionality. These outputs are designed to

drive 50Ω transmission lines. Matched impedance techniques should be used to maximize operating frequency and minimize signal distortion. *Figures 2A and 2B* show two different layouts which are recommended only as guidelines. Other suitable clock layouts may exist and it would be recommended that the board designers simulate to guarantee compatibility across all printed circuit and clock component process variations.

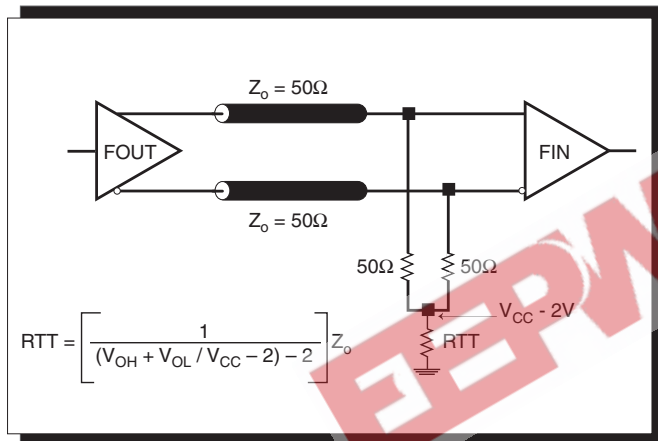

FIGURE 2A. LVPECL OUTPUT TERMINATION

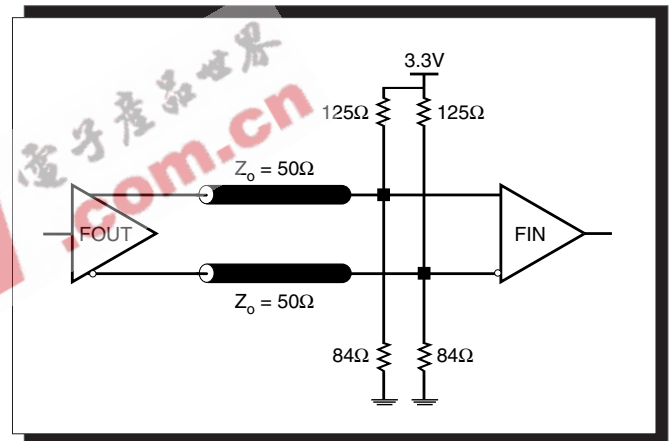

FIGURE 2B. LVPECL OUTPUT TERMINATION

CRYSTAL INPUT INTERFACE

The ICS84321I has been characterized with 18pF parallel resonant crystals. The capacitor values shown in *Figure 3* below were determined using a 25MHz, 18pF parallel resonant crystal and were chosen to minimize the ppm error. These same capacitor

values will tune any 18pF parallel resonant crystal over the frequency range of 14MHz to 40MHz providing the other parameters specified in *Table 6*, Crystal Characteristics, are satisfied.

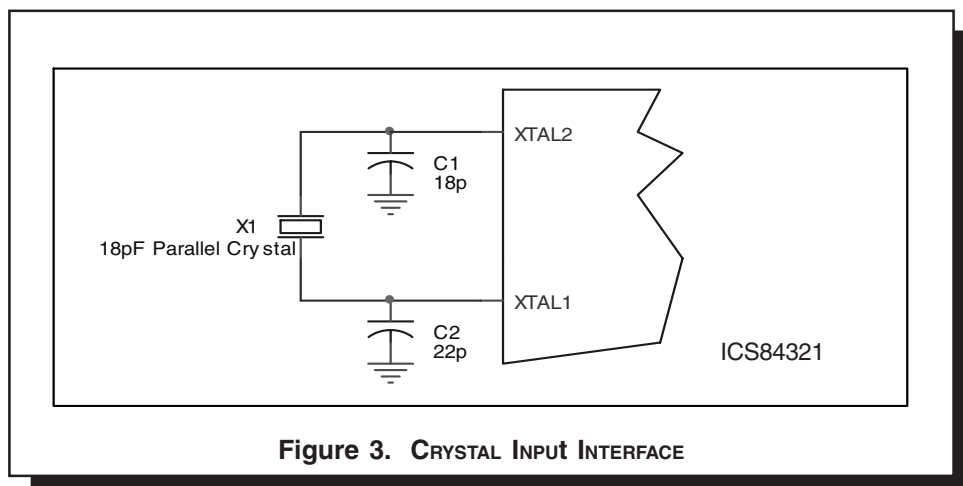

Figure 3. CRYSTAL INPUT INTERFACE



POWER SUPPLY FILTERING TECHNIQUES

As in any high speed analog circuitry, the power supply pins are vulnerable to random noise. The ICS84321 provides separate power supplies to isolate any high switching noise from the outputs to the internal PLL. V_{CC} , V_{CCA} , and V_{CCO} should be individually connected to the power supply plane through vias, and bypass capacitors should be used for each pin. To achieve optimum jitter performance, power supply isolation is required. Figure 4 illustrates how a 24Ω resistor along with a 10μF and a .01μF bypass capacitor should be connected to each V_{CCA} pin.

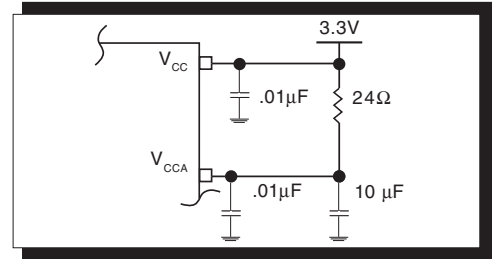

FIGURE 4. POWER SUPPLY FILTERING

LAYOUT GUIDELINE

The schematic of the ICS84321 layout example used in this layout guideline is shown in Figure 5A. The ICS84321 recommended PCB board layout for this example is shown in Figure 5B. This layout example is used as a general guideline. The layout in the

actual system will depend on the selected component types, the density of the components, the density of the traces, and the stack up of the P.C. board.

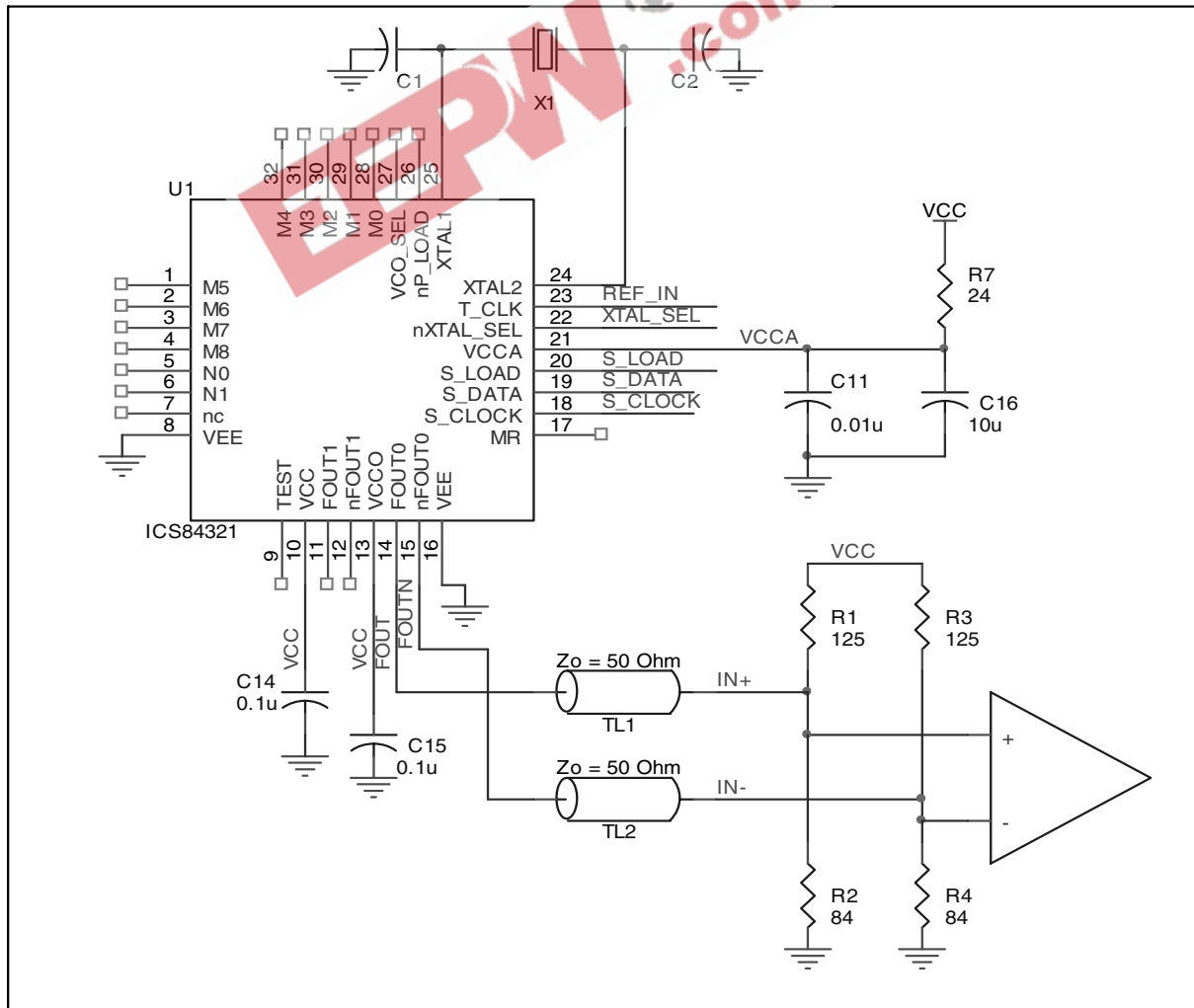

FIGURE 5A. SCHEMATIC OF RECOMMENDED LAYOUT



The following component footprints are used in this layout example:

All the resistors and capacitors are size 0603.

POWER AND GROUNDING

Place the decoupling capacitors C14 and C15, as close as possible to the power pins. If space allows, placement of the decoupling capacitor on the component side is preferred. This can reduce unwanted inductance between the decoupling capacitor and the power pin caused by the via.

Maximize the power and ground pad sizes and number of vias capacitors. This can reduce the inductance between the power and ground planes and the component power and ground pins.

The RC filter consisting of R7, C11, and C16 should be placed as close to the V_{CCA} pin as possible.

CLOCK TRACES AND TERMINATION

Poor signal integrity can degrade the system performance or cause system failure. In synchronous high-speed digital systems, the clock signal is less tolerant to poor signal integrity than other signals. Any ringing on the rising or falling edge or excessive ring back can cause system failure. The shape of the trace and the trace delay might be restricted by the available space on the board and the component location. While routing the traces, the clock signal traces should be routed first and should be locked prior to routing other signal traces.

- The differential 50Ω output traces should have the same length.
- Avoid sharp angles on the clock trace. Sharp angle turns cause the characteristic impedance to change on the transmission lines.
- Keep the clock traces on the same layer. Whenever possible, avoid placing vias on the clock traces. Placement of vias on the traces can affect the trace characteristic impedance and hence degrade signal integrity.
- To prevent cross talk, avoid routing other signal traces in parallel with the clock traces. If running parallel traces is unavoidable, allow a separation of at least three trace widths between the differential clock trace and the other signal trace.
- Make sure no other signal traces are routed between the clock trace pair.
- The matching termination resistors should be located as close to the receiver input pins as possible.

CRYSTAL

The crystal X1 should be located as close as possible to the pins 25 (XTAL1) and 24 (XTAL2). The trace length between the X1 and U1 should be kept to a minimum to avoid unwanted parasitic inductance and capacitance. Other signal traces should not be routed near the crystal traces.

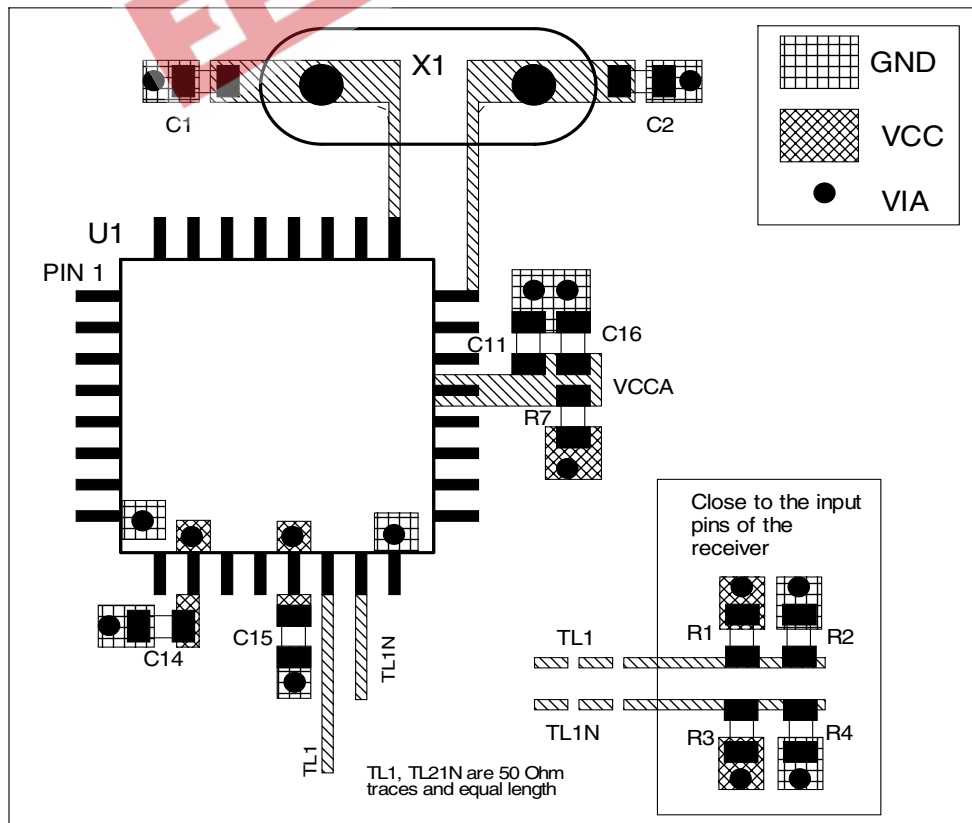

FIGURE 5B. PCB BOARD LAYOUT FOR ICS84321I



POWER CONSIDERATIONS

This section provides information on power dissipation and junction temperature for the ICS84321I. Equations and example calculations are also provided.

1. Power Dissipation.

The total power dissipation for the ICS84321I is the sum of the core power plus the power dissipated in the load(s). The following is the power dissipation for $V_{CC} = 3.3V + 5\% = 3.465V$, which gives worst case results.

NOTE: Please refer to Section 3 for details on calculating power dissipated in the load.

- Power (core)_{MAX} = $V_{CC_MAX} * I_{EE_MAX} = 3.465V * 180mA = 623.7mW$
- Power (outputs)_{MAX} = **30.2mW/Loaded Output pair**
If all outputs are loaded, the total power is $2 * 30.2mW = 60.4mW$

$$\text{Total Power}_{MAX} (3.465V, \text{ with all outputs switching}) = 623.7mW + 60.4mW = 684.1mW$$

2. Junction Temperature.

Junction temperature, T_j , is the temperature at the junction of the bond wire and bond pad and directly affects the reliability of the device. The maximum recommended junction temperature for HiPerClockS™ devices is 125°C.

The equation for T_j is as follows: $T_j = \theta_{JA} * Pd_total + T_A$

T_j = Junction Temperature

θ_{JA} = Junction-to-Ambient Thermal Resistance

Pd_total = Total Device Power Dissipation (example calculation is in section 1 above)

T_A = Ambient Temperature

In order to calculate junction temperature, the appropriate junction-to-ambient thermal resistance θ_{JA} must be used. Assuming a moderate air flow of 200 linear feet per minute and a multi-layer board, the appropriate value is 42.1°C/W per Table 8 below.

Therefore, T_j for an ambient temperature of 85°C with all outputs switching is:

$$85^\circ C + 0.684W * 42.1^\circ C/W = 113.8^\circ C. \text{ This is well below the limit of } 125^\circ C.$$

This calculation is only an example. T_j will obviously vary depending on the number of loaded outputs, supply voltage, air flow, and the type of board (single layer or multi-layer).

TABLE 8. THERMAL RESISTANCE θ_{JA} FOR 32-PIN LQFP, FORCED CONVECTION

θ_{JA} by Velocity (Linear Feet per Minute)			
	0	200	500
Single-Layer PCB, JEDEC Standard Test Boards	67.8°C/W	55.9°C/W	50.1°C/W
Multi-Layer PCB, JEDEC Standard Test Boards	47.9°C/W	42.1°C/W	39.4°C/W

NOTE: Most modern PCB designs use multi-layered boards. The data in the second row pertains to most designs.



3. Calculations and Equations.

The purpose of this section is to derive the power dissipated into the load.

LVPECL output driver circuit and termination are shown in *Figure 6*.

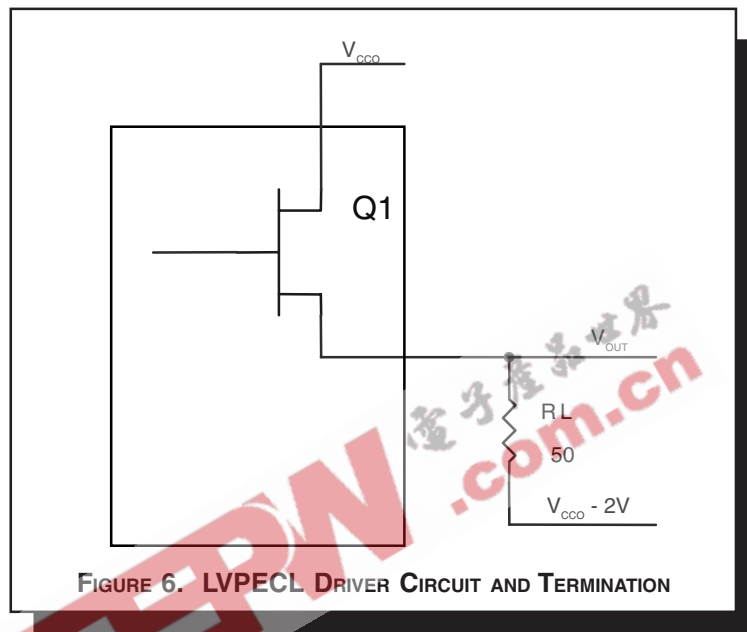

FIGURE 6. LVPECL DRIVER CIRCUIT AND TERMINATION

To calculate worst case power dissipation into the load, use the following equations which assume a 50Ω load, and a termination voltage of $V_{CCO} - 2V$.

- For logic high, $V_{OUT} = V_{OH_MAX} = V_{CCO_MAX} - 1.0V$

$$(V_{CCO_MAX} - V_{OH_MAX}) = 1.0V$$

- For logic low, $V_{OUT} = V_{OL_MAX} = V_{CCO_MAX} - 1.7V$

$$(V_{CCO_MAX} - V_{OL_MAX}) = 1.7V$$

Pd_H is power dissipation when the output drives high.

Pd_L is the power dissipation when the output drives low.

$$Pd_H = [(V_{OH_MAX} - (V_{CCO_MAX} - 2V))/R_L] * (V_{CCO_MAX} - V_{OH_MAX}) = [(2V - (V_{CCO_MAX} - V_{OH_MAX}))/R_L] * (V_{CCO_MAX} - V_{OH_MAX}) = [(2V - 1V)/50\Omega] * 1V = 20.0mW$$

$$Pd_L = [(V_{OL_MAX} - (V_{CCO_MAX} - 2V))/R_L] * (V_{CCO_MAX} - V_{OL_MAX}) = [(2V - (V_{CCO_MAX} - V_{OL_MAX}))/R_L] * (V_{CCO_MAX} - V_{OL_MAX}) = [(2V - 1.7V)/50\Omega] * 1.7V = 10.2mW$$

Total Power Dissipation per output pair = $Pd_H + Pd_L = 30.2mW$



Integrated
Circuit
Systems, Inc.

ICS84321I
260MHz, CRYSTAL-TO-3.3V DIFFERENTIAL
LVPECL FREQUENCY SYNTHESIZER

RELIABILITY INFORMATION

TABLE 9. θ_{JA} VS. AIR FLOW TABLE FOR 32 LEAD LQFP

θ_{JA} by Velocity (Linear Feet per Minute)			
	0	200	500
Single-Layer PCB, JEDEC Standard Test Boards	67.8°C/W	55.9°C/W	50.1°C/W
Multi-Layer PCB, JEDEC Standard Test Boards	47.9°C/W	42.1°C/W	39.4°C/W

NOTE: Most modern PCB designs use multi-layered boards. The data in the second row pertains to most designs.

TRANSISTOR COUNT

The transistor count for ICS84321I is: 3744

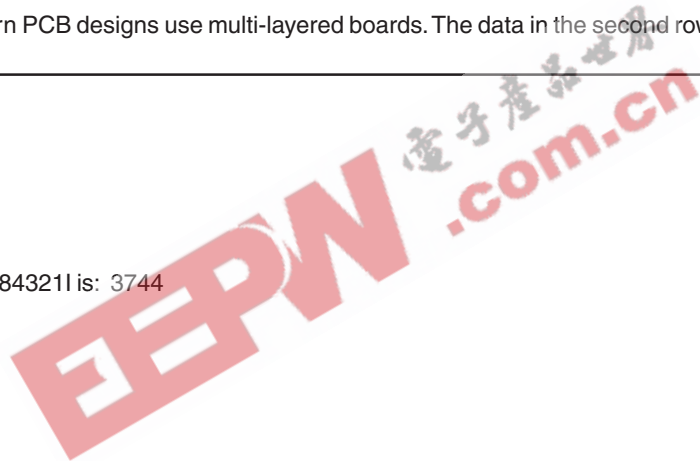



Integrated
Circuit
Systems, Inc.

ICS84321I

260MHz, CRYSTAL-TO-3.3V DIFFERENTIAL
LVPECL FREQUENCY SYNTHESIZER

PACKAGE OUTLINE - Y SUFFIX FOR 32 LEAD LQFP

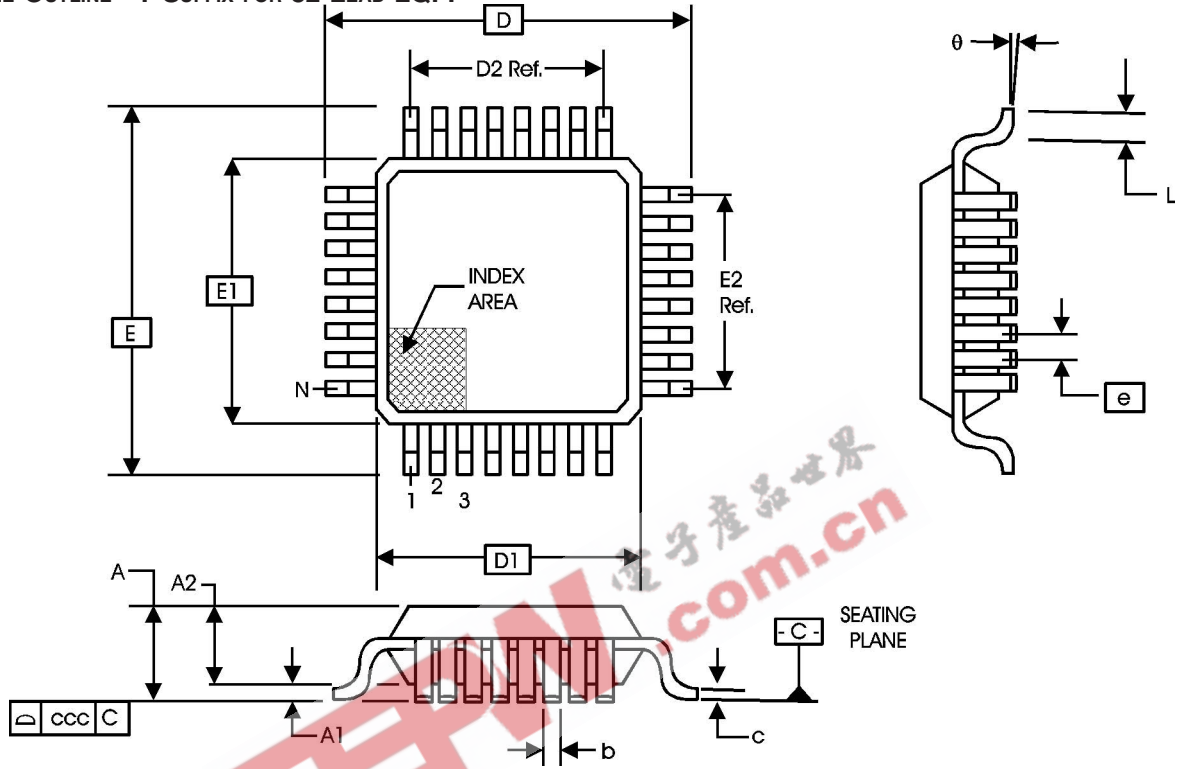

TABLE 10. PACKAGE DIMENSIONS

JEDEC VARIATION ALL DIMENSIONS IN MILLIMETERS			
SYMBOL	BBA		
	MINIMUM	NOMINAL	MAXIMUM
N	32		
A	--	--	1.60
A1	0.05	--	0.15
A2	1.35	1.40	1.45
b	0.30	0.37	0.45
c	0.09	--	0.20
D	9.00 BASIC		
D1	7.00 BASIC		
D2	5.60 Ref.		
E	9.00 BASIC		
E1	7.00 BASIC		
E2	5.60 Ref.		
e	0.80 BASIC		
L	0.45	0.60	0.75
theta	0°	--	7°
ccc	--	--	0.10

Reference Document: JEDEC Publication 95, MS-026



Integrated
Circuit
Systems, Inc.

ICS84321I

260MHz, CRYSTAL-TO-3.3V DIFFERENTIAL
LVPECL FREQUENCY SYNTHESIZER

TABLE 11. ORDERING INFORMATION

Part/Order Number	Marking	Package	Count	Temperature
ICS84321AYI	ICS84321AYI	32 Lead LQFP	250 per tray	-40°C to 85°C
ICS84321AYIT	ICS84321AYI	32 Lead LQFP on Tape and Reel	1000	-40°C to 85°C

EEPW 电子產品世界
.com.cn

While the information presented herein has been checked for both accuracy and reliability, Integrated Circuit Systems, Incorporated (ICS) assumes no responsibility for either its use or for infringement of any patents or other rights of third parties, which would result from its use. No other circuits, patents, or licenses are implied. This product is intended for use in normal commercial and industrial applications. Any other applications such as those requiring high reliability or other extraordinary environmental requirements are not recommended without additional processing by ICS. ICS reserves the right to change any circuitry or specifications without notice. ICS does not authorize or warrant any ICS product for use in life support devices or critical medical instruments.