

CY54FCT374T, CY74FCT374T 8-BIT REGISTERS WITH 3-STATE OUTPUTS

SCCS022A – MAY 1994 – REVISED OCTOBER 2001

- Function, Pinout, and Drive Compatible With FCT and F Logic
- Reduced V_{OH} (Typically = 3.3 V) Versions of Equivalent FCT Functions
- Edge-Rate Control Circuitry for Significantly Improved Noise Characteristics
- I_{off} Supports Partial-Power-Down Mode Operation
- Matched Rise and Fall Times
- Fully Compatible With TTL Input and Output Logic Levels
- ESD Protection Exceeds JESD 22
 - 2000-V Human-Body Model (A114-A)
 - 200-V Machine Model (A115-A)
 - 1000-V Charged-Device Model (C101)
- Edge-Triggered D-Type Inputs
- 250-MHz Typical Switching Rate
- CY54FCT374T
 - 32-mA Output Sink Current
 - 12-mA Output Source Current
- CY74FCT374T
 - 64-mA Output Sink Current
 - 32-mA Output Source Current
- 3-State Outputs

CY54FCT374T . . . D PACKAGE
CY74FCT374T . . . P, Q, OR SO PACKAGE
(TOP VIEW)

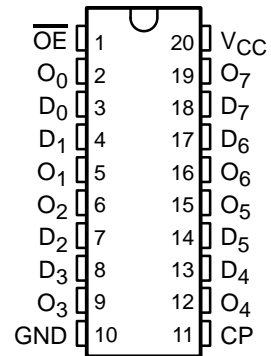

CY54FCT374T . . . L PACKAGE
(TOP VIEW)

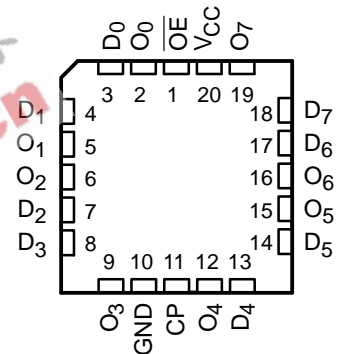

description

The 'FCT374T devices are high-speed, low-power, octal D-type flip-flops, featuring separate D-type inputs for each flip-flop. These devices have 3-state outputs for bus-oriented applications. A buffered clock (CP) and output-enable (\overline{OE}) inputs are common to all flip-flops. The eight flip-flops in the 'FCT374T store the state of their individual D inputs that meet the setup-time and hold-time requirements on the low-to-high CP transition. When \overline{OE} is low, the contents of the eight flip-flops are available at the outputs. When \overline{OE} is high, the outputs are in the high-impedance state. The state of \overline{OE} does not affect the state of the flip-flops.

These devices are fully specified for partial-power-down applications using I_{off} . The I_{off} circuitry disables the outputs, preventing damaging current backflow through the device when it is powered down.



Please be aware that an important notice concerning availability, standard warranty, and use in critical applications of Texas Instruments semiconductor products and disclaimers thereto appears at the end of this data sheet.

PRODUCTION DATA information is current as of publication date. Products conform to specifications per the terms of Texas Instruments standard warranty. Production processing does not necessarily include testing of all parameters.

 **TEXAS
INSTRUMENTS**

POST OFFICE BOX 655303 • DALLAS, TEXAS 75265

Copyright © 2001, Texas Instruments Incorporated
On products compliant to MIL-PRF-38535, all parameters are tested unless otherwise noted. On all other products, production processing does not necessarily include testing of all parameters.

CY54FCT374T, CY74FCT374T 8-BIT REGISTERS WITH 3-STATE OUTPUTS

SCCS022A – MAY 1994 – REVISED OCTOBER 2001

ORDERING INFORMATION

T _A	PACKAGE†		SPEED (ns)	ORDERABLE PART NUMBER	TOP-SIDE MARKING
-40°C to 85°C	QSOP – Q	Tape and reel	5.2	CY74FCT374CTQCT	FCT374C
	SOIC – SO	Tube	5.2	CY74FCT374CTSOC	FCT374C
		Tape and reel	5.2	CY74FCT374CTSOCT	
	DIP – P	Tube	6.5	CY74FCT374ATPC	CY74FCT374ATPC
	QSOP – Q	Tape and reel	6.5	CY74FCT374ATQCT	FCT374A
	SOIC – SO	Tube	6.5	CY74FCT374ATSOC	FCT374A
		Tape and reel	6.5	CY74FCT374ATSOCT	
	QSOP – Q	Tape and reel	10	CY74FCT374TQCT	FCT374
SOIC – SO	Tube	10	CY74FCT374TSOC	FCT374	
	Tape and reel	10	CY74FCT374TSOCT		
-55°C to 125°C	CDIP – D	Tube	6.2	CY54FCT374CTDMB	
	LCC – L	Tube	6.2	CY54FCT374CTLMB	
	CDIP – D	Tube	7.2	CY54FCT374ATDMB	
	LCC – L	Tube	7.2	CY54FCT374ATLMB	
	CDIP – D	Tube	11	CY54FCT374TDMB	
	LCC – L	Tube	11	CY54FCT374TLMB	

† Package drawings, standard packing quantities, thermal data, symbolization, and PCB design guidelines are available at www.ti.com/sc/package.

FUNCTION TABLE

INPUTS			OUTPUT
D	CP	\overline{OE}	O
H	↑	L	H
L	↑	L	L
X	X	H	Z

H = High logic level, L = Low logic level,
X = Don't care, Z = High-impedance state,
↑ = Low-to-high clock transition

logic diagram (positive logic)

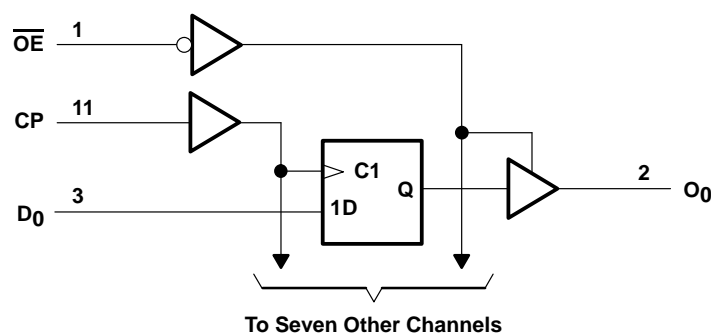

CY54FCT374T, CY74FCT374T
8-BIT REGISTERS
WITH 3-STATE OUTPUTS

SCCS022A – MAY 1994 – REVISED OCTOBER 2001

absolute maximum ratings over operating free-air temperature range (unless otherwise noted)†

Supply voltage range to ground potential	-0.5 V to 7 V
DC input voltage range	-0.5 V to 7 V
DC output voltage range	-0.5 V to 7 V
DC output current (maximum sink current/pin)	120 mA
Package thermal impedance, θ_{JA} (see Note 1): P package	69°C/W
Q package	68°C/W
SO package	58°C/W
Ambient temperature range with power applied, T_A	-65°C to 135°C
Storage temperature range, T_{stg}	-65°C to 150°C

† Stresses beyond those listed under “absolute maximum ratings” may cause permanent damage to the device. These are stress ratings only, and functional operation of the device at these or any other conditions beyond those indicated under “recommended operating conditions” is not implied. Exposure to absolute-maximum-rated conditions for extended periods may affect device reliability.

NOTE 1: The package thermal impedance is calculated in accordance with JESD 51-7.

recommended operating conditions (see Note 2)

	CY54FCT374T			CY74FCT374T			UNIT
	MIN	NOM	MAX	MIN	NOM	MAX	
V_{CC} Supply voltage	4.5	5	5.5	4.75	5	5.25	V
V_{IH} High-level input voltage	2			2			V
V_{IL} Low-level input voltage			0.8			0.8	V
I_{OH} High-level output current			-12			-32	mA
I_{OL} Low-level output current			32			64	mA
T_A Operating free-air temperature	-55		125	-40		85	°C

NOTE 2: All unused inputs of the device must be held at V_{CC} or GND to ensure proper device operation.

CY54FCT374T, CY74FCT374T

8-BIT REGISTERS

WITH 3-STATE OUTPUTS

SCCS022A – MAY 1994 – REVISED OCTOBER 2001

electrical characteristics over recommended operating free-air temperature range (unless otherwise noted)

PARAMETER	TEST CONDITIONS	CY54FCT374T			CY74FCT374T			UNIT
		MIN	TYP†	MAX	MIN	TYP†	MAX	
V _{IK}	V _{CC} = 4.5 V, I _{IN} = -18 mA		-0.7	-1.2				V
	V _{CC} = 4.75 V, I _{IN} = -18 mA				-0.7	-1.2		
V _{OH}	V _{CC} = 4.5 V, I _{OH} = -12 mA	2.4	3.3					V
	V _{CC} = 4.75 V	I _{OH} = -32 mA			2			
		I _{OH} = -15 mA				2.4	3.3	
V _{OL}	V _{CC} = 4.5 V, I _{OL} = 32 mA		0.3	0.55				V
	V _{CC} = 4.75 V, I _{OL} = 64 mA				0.3	0.55		
V _{hys}	All inputs		0.2		0.2			V
I _I	V _{CC} = 5.5 V, V _{IN} = V _{CC}			5				μA
	V _{CC} = 5.25 V, V _{IN} = V _{CC}					5		
I _{IH}	V _{CC} = 5.5 V, V _{IN} = 2.7 V			±1				μA
	V _{CC} = 5.25 V, V _{IN} = 2.7 V					±1		
I _{IL}	V _{CC} = 5.5 V, V _{IN} = 0.5 V			±1				μA
	V _{CC} = 5.25 V, V _{IN} = 0.5 V					±1		
I _{off}	V _{CC} = 0 V, V _{OUT} = 4.5 V			±1		±1		μA
I _{OS} ‡	V _{CC} = 5.5 V, V _{OUT} = 0 V	-60	-120	-225				mA
	V _{CC} = 5.25 V, V _{OUT} = 0 V				-60	-120	-225	
I _{OZH}	V _{CC} = 5.5 V, V _{IN} = 2.7 V			10				μA
	V _{CC} = 5.25 V, V _{IN} = 2.7 V					10		
I _{OZL}	V _{CC} = 5.5 V, V _{IN} = 0.5 V			-10				μA
	V _{CC} = 5.25 V, V _{IN} = 0.5 V					-10		
I _{CC}	V _{CC} = 5.5 V, V _{IN} ≤ 0.2 V, V _{IN} ≥ V _{CC} - 0.2 V		0.1	0.2				mA
	V _{CC} = 5.25 V, V _{IN} ≤ 0.2 V, V _{IN} ≥ V _{CC} - 0.2 V				0.1	0.2		
ΔI _{CC}	V _{CC} = 5.5 V, V _{IN} = 3.4 V§, f ₁ = 0, Outputs open		0.5	2				mA
	V _{CC} = 5.25 V, V _{IN} = 3.4 V§, f ₁ = 0, Outputs open				0.5	2		

† Typical values are at V_{CC} = 5 V, T_A = 25°C.

‡ Not more than one output should be shorted at a time. Duration of short should not exceed one second. The use of high-speed test apparatus and/or sample-and-hold techniques are preferable to minimize internal chip heating and more accurately reflect operational values. Otherwise, prolonged shorting of a high output can raise the chip temperature well above normal and cause invalid readings in other parametric tests. In any sequence of parameter tests, I_{OS} tests should be performed last.

§ Per TTL-driven input (V_{IN} = 3.4 V); all other inputs at V_{CC} or GND

CY54FCT374T, CY74FCT374T
8-BIT REGISTERS
WITH 3-STATE OUTPUTS

SCCS022A – MAY 1994 – REVISED OCTOBER 2001

electrical characteristics over recommended operating free-air temperature range (unless otherwise noted) (continued)

PARAMETER	TEST CONDITIONS		CY54FCT374T			CY74FCT374T			UNIT
			MIN	TYP†	MAX	MIN	TYP†	MAX	
I_{CCD}^{\ddagger}	$V_{CC} = 5.5\text{ V}$, Outputs open, One bit switching at 50% duty cycle, $\overline{OE} = \text{GND}$, $V_{IN} \leq 0.2\text{ V}$ or $V_{IN} \geq V_{CC} - 0.2\text{ V}$			0.06	0.12				mA/ MHz
	$V_{CC} = 5.25\text{ V}$, Outputs open, One bit switching at 50% duty cycle, $\overline{OE} = \text{GND}$, $V_{IN} \leq 0.2\text{ V}$ or $V_{IN} \geq V_{CC} - 0.2\text{ V}$					0.06	0.12		
I_C	$V_{CC} = 5.5\text{ V}$, $f_0 = 10\text{ MHz}$, Outputs open, $\overline{OE} = \text{GND}$	One bit switching at $f_1 = 5\text{ MHz}$ at 50% duty cycle	$V_{IN} \leq 0.2\text{ V}$ or $V_{IN} \geq V_{CC} - 0.2\text{ V}$	0.7	1.4				mA
			$V_{IN} = 3.4\text{ V}$ or GND	1.2	3.4				
		Eight bits switching at $f_1 = 2.5\text{ MHz}$ at 50% duty cycle	$V_{IN} \leq 0.2\text{ V}$ or $V_{IN} \geq V_{CC} - 0.2\text{ V}$	1.6	3.2				
			$V_{IN} = 3.4\text{ V}$ or GND	3.9	12.2				
	$V_{CC} = 5.25\text{ V}$, $f_0 = 10\text{ MHz}$, Outputs open, $\overline{OE} = \text{GND}$	One bit switching at $f_1 = 5\text{ MHz}$ at 50% duty cycle	$V_{IN} \leq 0.2\text{ V}$ or $V_{IN} \geq V_{CC} - 0.2\text{ V}$			0.7	1.4		
			$V_{IN} = 3.4\text{ V}$ or GND			1.2	3.4		
		Eight bits switching at $f_1 = 2.5\text{ MHz}$ at 50% duty cycle	$V_{IN} \leq 0.2\text{ V}$ or $V_{IN} \geq V_{CC} - 0.2\text{ V}$			1.6	3.2		
			$V_{IN} = 3.4\text{ V}$ or GND			3.9	12.2		
C_i				5	10		5	10	pF
C_o				9	12		9	12	pF

† Typical values are at $V_{CC} = 5\text{ V}$, $T_A = 25^\circ\text{C}$.

‡ This parameter is derived for use in total power-supply calculations.

$I_C = I_{CC} + \Delta I_{CC} \times D_H \times N_T + I_{CCD} (f_0/2 + f_1 \times N_1)$

Where:

I_C = Total supply current

I_{CC} = Power-supply current with CMOS input levels

ΔI_{CC} = Power-supply current for a TTL high input ($V_{IN} = 3.4\text{ V}$)

D_H = Duty cycle for TTL inputs high

N_T = Number of TTL inputs at D_H

I_{CCD} = Dynamic current caused by an input transition pair (HLH or LHL)

f_0 = Clock frequency for registered devices, otherwise zero

f_1 = Input signal frequency

N_1 = Number of inputs changing at f_1

All currents are in milliamperes and all frequencies are in megahertz.

|| Values for these conditions are examples of the I_{CC} formula.

CY54FCT374T, CY74FCT374T
8-BIT REGISTERS
WITH 3-STATE OUTPUTS

SCCS022A – MAY 1994 – REVISED OCTOBER 2001

timing requirements over recommended operating free-air temperature range (unless otherwise noted) (see Figure 1)

		CY54FCT374T		CY54FCT374AT		CY54FCT374CT		UNIT
		MIN	MAX	MIN	MAX	MIN	MAX	
t_w	Pulse duration, CP high or low	7		6		6		ns
t_{su}	Setup time, data before CP \uparrow	2		2		2		ns
t_h	Hold time, data after CP \uparrow	1.5		1.5		1.5		ns

timing requirements over recommended operating free-air temperature range (unless otherwise noted) (see Figure 1)

		CY74FCT374T		CY74FCT374AT		CY74FCT374CT		UNIT
		MIN	MAX	MIN	MAX	MIN	MAX	
t_w	Pulse duration, CP high or low	7		5		5		ns
t_{su}	Setup time, data before CP \uparrow	2		2		2		ns
t_h	Hold time, data after CP \uparrow	1.5		1.5		1.5		ns

switching characteristics over operating free-air temperature range (see Figure 1)

PARAMETER	FROM (INPUT)	TO (OUTPUT)	CY54FCT374T		CY54FCT374AT		CY54FCT374CT		UNIT
			MIN	MAX	MIN	MAX	MIN	MAX	
t_{PLH}	CP	O	2	11	2	7.2	2	6.2	ns
t_{PHL}			2	11	2	7.2	2	6.2	
t_{PZH}	\overline{OE}	O	1.5	14	1.5	7.5	1.5	6.2	ns
t_{PZL}			1.5	14	1.5	7.5	1.5	6.2	
t_{PHZ}	\overline{OE}	O	1.5	8	1.5	6.5	1.5	5.7	ns
t_{PLZ}			1.5	8	1.5	6.5	1.5	5.7	

switching characteristics over operating free-air temperature range (see Figure 1)

PARAMETER	FROM (INPUT)	TO (OUTPUT)	CY74FCT374T		CY74FCT374AT		CY74FCT374CT		UNIT
			MIN	MAX	MIN	MAX	MIN	MAX	
t_{PLH}	CP	O	2	10	2	6.5	2	5.2	ns
t_{PHL}			2	10	2	6.5	2	5.2	
t_{PZH}	\overline{OE}	O	1.5	12.5	1.5	6.5	1.5	5.5	ns
t_{PZL}			1.5	12.5	1.5	6.5	1.5	5.5	
t_{PHZ}	\overline{OE}	O	1.5	8	1.5	5.5	1.5	5	ns
t_{PLZ}			1.5	8	1.5	5.5	1.5	5	

CY54FCT374T, CY74FCT374T 8-BIT REGISTERS WITH 3-STATE OUTPUTS

SCCS022A – MAY 1994 – REVISED OCTOBER 2001

PARAMETER MEASUREMENT INFORMATION

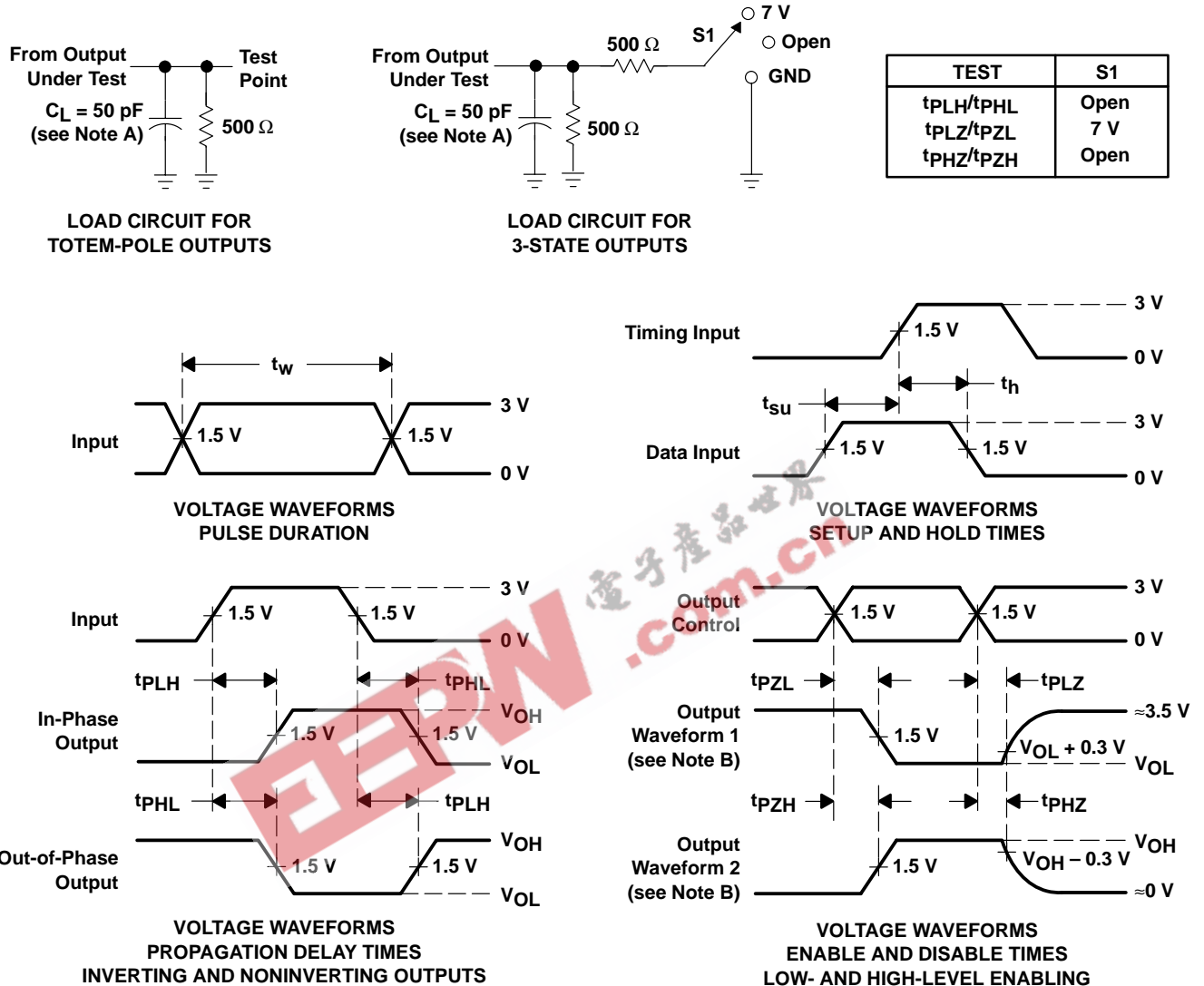

- NOTES: A. C_L includes probe and jig capacitance.
 B. Waveform 1 is for an output with internal conditions such that the output is low except when disabled by the output control. Waveform 2 is for an output with internal conditions such that the output is high except when disabled by the output control.
 C. The outputs are measured one at a time with one input transition per measurement.

Figure 1. Load Circuit and Voltage Waveforms

PACKAGING INFORMATION

Orderable Device	Status ⁽¹⁾	Package Type	Package Drawing	Pins	Package Qty	Eco Plan ⁽²⁾	Lead/Ball Finish	MSL Peak Temp ⁽³⁾
5962-9221802M2A	ACTIVE	LCCC	FK	20	1	TBD	POST-PLATE	N / A for Pkg Type
5962-9221802MRA	ACTIVE	CDIP	J	20	1	TBD	A42 SNPB	N / A for Pkg Type
5962-9221804M2A	ACTIVE	LCCC	FK	20	1	TBD	POST-PLATE	N / A for Pkg Type
5962-9221804MRA	ACTIVE	CDIP	J	20	1	TBD	A42 SNPB	N / A for Pkg Type
5962-9221806M2A	ACTIVE	LCCC	FK	20	1	TBD	POST-PLATE	N / A for Pkg Type
5962-9221806MRA	ACTIVE	CDIP	J	20	1	TBD	A42 SNPB	N / A for Pkg Type
5962-9222203M2A	ACTIVE	LCCC	FK	20	1	TBD	POST-PLATE	N / A for Pkg Type
5962-9222203MRA	ACTIVE	CDIP	J	20	1	TBD	A42 SNPB	N / A for Pkg Type
5962-9222205MRA	ACTIVE	CDIP	J	20	1	TBD	A42 SNPB	N / A for Pkg Type
CY54FCT374ATDMB	ACTIVE	CDIP	J	20	1	TBD	A42 SNPB	N / A for Pkg Type
CY54FCT374ATLMB	ACTIVE	LCCC	FK	20	1	TBD	POST-PLATE	N / A for Pkg Type
CY54FCT374CTLMB	ACTIVE	LCCC	FK	20	1	TBD	POST-PLATE	N / A for Pkg Type
CY54FCT374TDMB	ACTIVE	CDIP	J	20	1	TBD	A42 SNPB	N / A for Pkg Type
CY54FCT374TLMB	ACTIVE	LCCC	FK	20	1	TBD	POST-PLATE	N / A for Pkg Type
CY54FCT574ATLMB	ACTIVE	LCCC	FK	20	1	TBD	POST-PLATE	N / A for Pkg Type
CY74FCT374ATPC	ACTIVE	PDIP	N	20	20	Pb-Free (RoHS)	CU NIPDAU	N / A for Pkg Type
CY74FCT374ATPCE4	ACTIVE	PDIP	N	20	20	Pb-Free (RoHS)	CU NIPDAU	N / A for Pkg Type
CY74FCT374ATQCT	ACTIVE	SSOP/ QSOP	DBQ	20	2500	Green (RoHS & no Sb/Br)	CU NIPDAU	Level-2-260C-1 YEAR
CY74FCT374ATQCTE4	ACTIVE	SSOP/ QSOP	DBQ	20	2500	Green (RoHS & no Sb/Br)	CU NIPDAU	Level-2-260C-1 YEAR
CY74FCT374ATQCTG4	ACTIVE	SSOP/ QSOP	DBQ	20	2500	Green (RoHS & no Sb/Br)	CU NIPDAU	Level-2-260C-1 YEAR
CY74FCT374ATSOC	ACTIVE	SOIC	DW	20	25	Green (RoHS & no Sb/Br)	CU NIPDAU	Level-1-260C-UNLIM
CY74FCT374ATSOCE4	ACTIVE	SOIC	DW	20	25	Green (RoHS & no Sb/Br)	CU NIPDAU	Level-1-260C-UNLIM
CY74FCT374ATSOCG4	ACTIVE	SOIC	DW	20	25	Green (RoHS & no Sb/Br)	CU NIPDAU	Level-1-260C-UNLIM
CY74FCT374ATSOCT	ACTIVE	SOIC	DW	20	2000	Green (RoHS & no Sb/Br)	CU NIPDAU	Level-1-260C-UNLIM
CY74FCT374ATSOCTE4	ACTIVE	SOIC	DW	20	2000	Green (RoHS & no Sb/Br)	CU NIPDAU	Level-1-260C-UNLIM
CY74FCT374ATSOCTG4	ACTIVE	SOIC	DW	20	2000	Green (RoHS & no Sb/Br)	CU NIPDAU	Level-1-260C-UNLIM
CY74FCT374CTQCT	ACTIVE	SSOP/ QSOP	DBQ	20	2500	Green (RoHS & no Sb/Br)	CU NIPDAU	Level-2-260C-1 YEAR
CY74FCT374CTQCTE4	ACTIVE	SSOP/ QSOP	DBQ	20	2500	Green (RoHS & no Sb/Br)	CU NIPDAU	Level-2-260C-1 YEAR
CY74FCT374CTQCTG4	ACTIVE	SSOP/ QSOP	DBQ	20	2500	Green (RoHS & no Sb/Br)	CU NIPDAU	Level-2-260C-1 YEAR
CY74FCT374CTSOC	ACTIVE	SOIC	DW	20	25	Green (RoHS & no Sb/Br)	CU NIPDAU	Level-1-260C-UNLIM
CY74FCT374CTSOCE4	ACTIVE	SOIC	DW	20	25	Green (RoHS & no Sb/Br)	CU NIPDAU	Level-1-260C-UNLIM

Orderable Device	Status ⁽¹⁾	Package Type	Package Drawing	Pins	Package Qty	Eco Plan ⁽²⁾	Lead/Ball Finish	MSL Peak Temp ⁽³⁾
CY74FCT374CTSOCG4	ACTIVE	SOIC	DW	20	25	Green (RoHS & no Sb/Br)	CU NIPDAU	Level-1-260C-UNLIM
CY74FCT374CTSOCT	ACTIVE	SOIC	DW	20	2000	Green (RoHS & no Sb/Br)	CU NIPDAU	Level-1-260C-UNLIM
CY74FCT374CTSOCTE4	ACTIVE	SOIC	DW	20	2000	Green (RoHS & no Sb/Br)	CU NIPDAU	Level-1-260C-UNLIM
CY74FCT374CTSOCTG4	ACTIVE	SOIC	DW	20	2000	Green (RoHS & no Sb/Br)	CU NIPDAU	Level-1-260C-UNLIM
CY74FCT374TQCT	ACTIVE	SSOP/ QSOP	DBQ	20	2500	Green (RoHS & no Sb/Br)	CU NIPDAU	Level-2-260C-1 YEAR
CY74FCT374TQCTE4	ACTIVE	SSOP/ QSOP	DBQ	20	2500	Green (RoHS & no Sb/Br)	CU NIPDAU	Level-2-260C-1 YEAR
CY74FCT374TQCTG4	ACTIVE	SSOP/ QSOP	DBQ	20	2500	Green (RoHS & no Sb/Br)	CU NIPDAU	Level-2-260C-1 YEAR
CY74FCT374TSOC	ACTIVE	SOIC	DW	20	25	Green (RoHS & no Sb/Br)	CU NIPDAU	Level-1-260C-UNLIM
CY74FCT374TSOCE4	ACTIVE	SOIC	DW	20	25	Green (RoHS & no Sb/Br)	CU NIPDAU	Level-1-260C-UNLIM
CY74FCT374TSOCG4	ACTIVE	SOIC	DW	20	25	Green (RoHS & no Sb/Br)	CU NIPDAU	Level-1-260C-UNLIM
CY74FCT374TSOCT	ACTIVE	SOIC	DW	20	2000	Green (RoHS & no Sb/Br)	CU NIPDAU	Level-1-260C-UNLIM
CY74FCT374TSOCTE4	ACTIVE	SOIC	DW	20	2000	Green (RoHS & no Sb/Br)	CU NIPDAU	Level-1-260C-UNLIM
CY74FCT374TSOCTG4	ACTIVE	SOIC	DW	20	2000	Green (RoHS & no Sb/Br)	CU NIPDAU	Level-1-260C-UNLIM
CY74FCT574ATQCT	ACTIVE	SSOP/ QSOP	DBQ	20	2500	Green (RoHS & no Sb/Br)	CU NIPDAU	Level-2-260C-1 YEAR
CY74FCT574ATQCTE4	ACTIVE	SSOP/ QSOP	DBQ	20	2500	Green (RoHS & no Sb/Br)	CU NIPDAU	Level-2-260C-1 YEAR
CY74FCT574ATQCTG4	ACTIVE	SSOP/ QSOP	DBQ	20	2500	Green (RoHS & no Sb/Br)	CU NIPDAU	Level-2-260C-1 YEAR
CY74FCT574ATSOC	ACTIVE	SOIC	DW	20	25	Green (RoHS & no Sb/Br)	CU NIPDAU	Level-1-260C-UNLIM
CY74FCT574ATSOCE4	ACTIVE	SOIC	DW	20	25	Green (RoHS & no Sb/Br)	CU NIPDAU	Level-1-260C-UNLIM
CY74FCT574ATSOCG4	ACTIVE	SOIC	DW	20	25	Green (RoHS & no Sb/Br)	CU NIPDAU	Level-1-260C-UNLIM
CY74FCT574ATSOCT	ACTIVE	SOIC	DW	20	2000	Green (RoHS & no Sb/Br)	CU NIPDAU	Level-1-260C-UNLIM
CY74FCT574ATSOCTE4	ACTIVE	SOIC	DW	20	2000	Green (RoHS & no Sb/Br)	CU NIPDAU	Level-1-260C-UNLIM
CY74FCT574ATSOCTG4	ACTIVE	SOIC	DW	20	2000	Green (RoHS & no Sb/Br)	CU NIPDAU	Level-1-260C-UNLIM
CY74FCT574CTQCT	ACTIVE	SSOP/ QSOP	DBQ	20	2500	Green (RoHS & no Sb/Br)	CU NIPDAU	Level-2-260C-1 YEAR
CY74FCT574CTQCTE4	ACTIVE	SSOP/ QSOP	DBQ	20	2500	Green (RoHS & no Sb/Br)	CU NIPDAU	Level-2-260C-1 YEAR
CY74FCT574CTQCTG4	ACTIVE	SSOP/ QSOP	DBQ	20	2500	Green (RoHS & no Sb/Br)	CU NIPDAU	Level-2-260C-1 YEAR
CY74FCT574CTSOC	ACTIVE	SOIC	DW	20	25	Green (RoHS & no Sb/Br)	CU NIPDAU	Level-1-260C-UNLIM

Orderable Device	Status ⁽¹⁾	Package Type	Package Drawing	Pins	Package Qty	Eco Plan ⁽²⁾	Lead/Ball Finish	MSL Peak Temp ⁽³⁾
CY74FCT574CTSOCE4	ACTIVE	SOIC	DW	20	25	Green (RoHS & no Sb/Br)	CU NIPDAU	Level-1-260C-UNLIM
CY74FCT574CTSOCG4	ACTIVE	SOIC	DW	20	25	Green (RoHS & no Sb/Br)	CU NIPDAU	Level-1-260C-UNLIM
CY74FCT574CTSOCT	ACTIVE	SOIC	DW	20	2000	Green (RoHS & no Sb/Br)	CU NIPDAU	Level-1-260C-UNLIM
CY74FCT574CTSOCTE4	ACTIVE	SOIC	DW	20	2000	Green (RoHS & no Sb/Br)	CU NIPDAU	Level-1-260C-UNLIM
CY74FCT574CTSOCYG4	ACTIVE	SOIC	DW	20	2000	Green (RoHS & no Sb/Br)	CU NIPDAU	Level-1-260C-UNLIM
CY74FCT574TQCT	ACTIVE	SSOP/QSOP	DBQ	20	2500	Green (RoHS & no Sb/Br)	CU NIPDAU	Level-2-260C-1 YEAR
CY74FCT574TQCTE4	ACTIVE	SSOP/QSOP	DBQ	20	2500	Green (RoHS & no Sb/Br)	CU NIPDAU	Level-2-260C-1 YEAR
CY74FCT574TQCTG4	ACTIVE	SSOP/QSOP	DBQ	20	2500	Green (RoHS & no Sb/Br)	CU NIPDAU	Level-2-260C-1 YEAR
CY74FCT574TSOC	ACTIVE	SOIC	DW	20	25	Green (RoHS & no Sb/Br)	CU NIPDAU	Level-1-260C-UNLIM
CY74FCT574TSOCE4	ACTIVE	SOIC	DW	20	25	Green (RoHS & no Sb/Br)	CU NIPDAU	Level-1-260C-UNLIM
CY74FCT574TSOCG4	ACTIVE	SOIC	DW	20	25	Green (RoHS & no Sb/Br)	CU NIPDAU	Level-1-260C-UNLIM
CY74FCT574TSOCT	ACTIVE	SOIC	DW	20	2000	Green (RoHS & no Sb/Br)	CU NIPDAU	Level-1-260C-UNLIM
CY74FCT574TSOCTE4	ACTIVE	SOIC	DW	20	2000	Green (RoHS & no Sb/Br)	CU NIPDAU	Level-1-260C-UNLIM
CY74FCT574TSOCTG4	ACTIVE	SOIC	DW	20	2000	Green (RoHS & no Sb/Br)	CU NIPDAU	Level-1-260C-UNLIM

⁽¹⁾ The marketing status values are defined as follows:

ACTIVE: Product device recommended for new designs.

LIFEBUY: TI has announced that the device will be discontinued, and a lifetime-buy period is in effect.

NRND: Not recommended for new designs. Device is in production to support existing customers, but TI does not recommend using this part in a new design.

PREVIEW: Device has been announced but is not in production. Samples may or may not be available.

OBSOLETE: TI has discontinued the production of the device.

⁽²⁾ Eco Plan - The planned eco-friendly classification: Pb-Free (RoHS), Pb-Free (RoHS Exempt), or Green (RoHS & no Sb/Br) - please check <http://www.ti.com/productcontent> for the latest availability information and additional product content details.

TBD: The Pb-Free/Green conversion plan has not been defined.

Pb-Free (RoHS): TI's terms "Lead-Free" or "Pb-Free" mean semiconductor products that are compatible with the current RoHS requirements for all 6 substances, including the requirement that lead not exceed 0.1% by weight in homogeneous materials. Where designed to be soldered at high temperatures, TI Pb-Free products are suitable for use in specified lead-free processes.

Pb-Free (RoHS Exempt): This component has a RoHS exemption for either 1) lead-based flip-chip solder bumps used between the die and package, or 2) lead-based die adhesive used between the die and leadframe. The component is otherwise considered Pb-Free (RoHS compatible) as defined above.

Green (RoHS & no Sb/Br): TI defines "Green" to mean Pb-Free (RoHS compatible), and free of Bromine (Br) and Antimony (Sb) based flame retardants (Br or Sb do not exceed 0.1% by weight in homogeneous material)

⁽³⁾ MSL, Peak Temp. -- The Moisture Sensitivity Level rating according to the JEDEC industry standard classifications, and peak solder temperature.

Important Information and Disclaimer: The information provided on this page represents TI's knowledge and belief as of the date that it is provided. TI bases its knowledge and belief on information provided by third parties, and makes no representation or warranty as to the accuracy of such information. Efforts are underway to better integrate information from third parties. TI has taken and continues to take

reasonable steps to provide representative and accurate information but may not have conducted destructive testing or chemical analysis on incoming materials and chemicals. TI and TI suppliers consider certain information to be proprietary, and thus CAS numbers and other limited information may not be available for release.

In no event shall TI's liability arising out of such information exceed the total purchase price of the TI part(s) at issue in this document sold by TI to Customer on an annual basis.

EEPW 电子產品世界
.com.cn

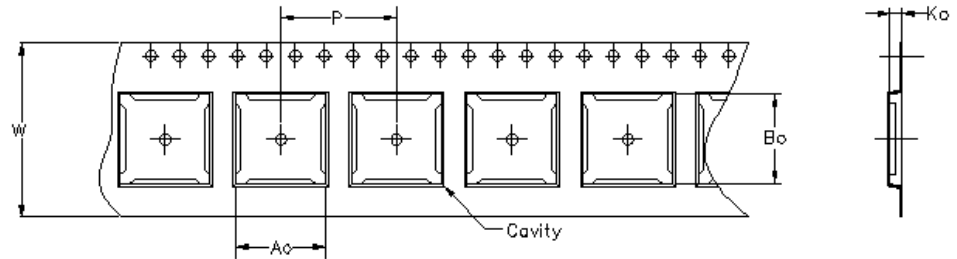

Carrier tape design is defined largely by the component length, width, and thickness.

A_o = Dimension designed to accommodate the component width.
B_o = Dimension designed to accommodate the component length.
K_o = Dimension designed to accommodate the component thickness.
W = Overall width of the carrier tape.
P = Pitch between successive cavity centers.

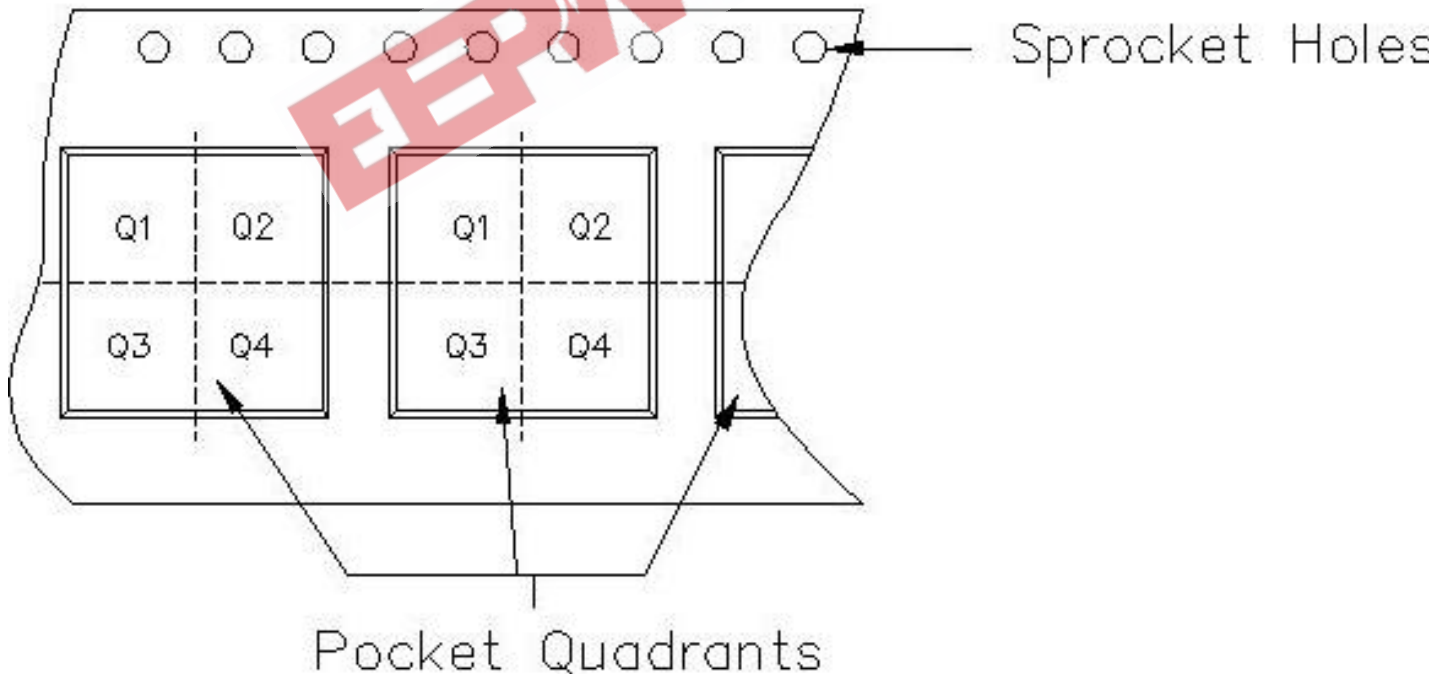

TAPE AND REEL INFORMATION

Device	Package	Pins	Site	Reel Diameter (mm)	Reel Width (mm)	A0 (mm)	B0 (mm)	K0 (mm)	P1 (mm)	W (mm)	Pin1 Quadrant
CY74FCT374ATQCT	DBQ	20	MLA	330	16	6.5	9.0	2.1	8	16	Q1
CY74FCT374ATSOCT	DW	20	MLA	330	24	10.8	13.0	2.7	12	24	Q1
CY74FCT374CTQCT	DBQ	20	MLA	330	16	6.5	9.0	2.1	8	16	Q1
CY74FCT374CTSOCT	DW	20	MLA	330	24	10.8	13.0	2.7	12	24	Q1
CY74FCT374TQCT	DBQ	20	MLA	330	16	6.5	9.0	2.1	8	16	Q1
CY74FCT374TSOCT	DW	20	MLA	330	24	10.8	13.0	2.7	12	24	Q1
CY74FCT574ATQCT	DBQ	20	MLA	330	16	6.5	9.0	2.1	8	16	Q1
CY74FCT574ATSOCT	DW	20	MLA	330	24	10.8	13.0	2.7	12	24	Q1
CY74FCT574CTQCT	DBQ	20	MLA	330	16	6.5	9.0	2.1	8	16	Q1
CY74FCT574CTSOCT	DW	20	MLA	330	24	10.8	13.0	2.7	12	24	Q1
CY74FCT574TQCT	DBQ	20	MLA	330	16	6.5	9.0	2.1	8	16	Q1
CY74FCT574TSOCT	DW	20	MLA	330	24	10.8	13.0	2.7	12	24	Q1

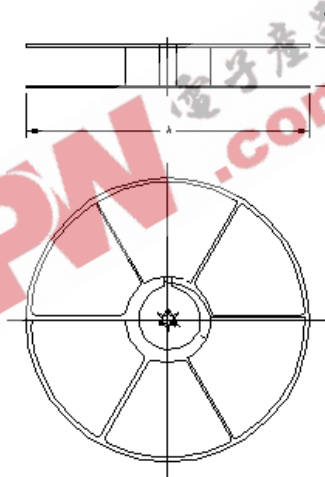

TAPE AND REEL BOX INFORMATION

Device	Package	Pins	Site	Length (mm)	Width (mm)	Height (mm)
CY74FCT374ATQCT	DBQ	20	MLA	0.0	0.0	0.0
CY74FCT374ATSOCT	DW	20	MLA	333.2	333.2	31.75
CY74FCT374CTQCT	DBQ	20	MLA	0.0	0.0	0.0
CY74FCT374CTSOCT	DW	20	MLA	333.2	333.2	31.75
CY74FCT374TQCT	DBQ	20	MLA	0.0	0.0	0.0
CY74FCT374TSOCT	DW	20	MLA	333.2	333.2	31.75
CY74FCT574ATQCT	DBQ	20	MLA	0.0	0.0	0.0
CY74FCT574ATSOCT	DW	20	MLA	333.2	333.2	31.75
CY74FCT574CTQCT	DBQ	20	MLA	0.0	0.0	0.0

Device	Package	Pins	Site	Length (mm)	Width (mm)	Height (mm)
CY74FCT574CTSOCT	DW	20	MLA	333.2	333.2	31.75
CY74FCT574TQCT	DBQ	20	MLA	0.0	0.0	0.0
CY74FCT574TSOCT	DW	20	MLA	333.2	333.2	31.75

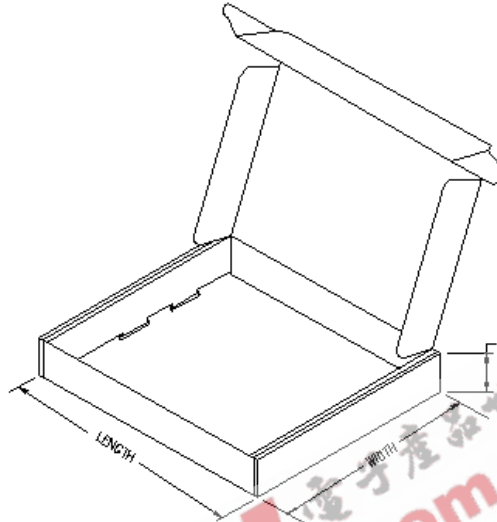

IMPORTANT NOTICE

Texas Instruments Incorporated and its subsidiaries (TI) reserve the right to make corrections, modifications, enhancements, improvements, and other changes to its products and services at any time and to discontinue any product or service without notice. Customers should obtain the latest relevant information before placing orders and should verify that such information is current and complete. All products are sold subject to TI's terms and conditions of sale supplied at the time of order acknowledgment.

TI warrants performance of its hardware products to the specifications applicable at the time of sale in accordance with TI's standard warranty. Testing and other quality control techniques are used to the extent TI deems necessary to support this warranty. Except where mandated by government requirements, testing of all parameters of each product is not necessarily performed.

TI assumes no liability for applications assistance or customer product design. Customers are responsible for their products and applications using TI components. To minimize the risks associated with customer products and applications, customers should provide adequate design and operating safeguards.

TI does not warrant or represent that any license, either express or implied, is granted under any TI patent right, copyright, mask work right, or other TI intellectual property right relating to any combination, machine, or process in which TI products or services are used. Information published by TI regarding third-party products or services does not constitute a license from TI to use such products or services or a warranty or endorsement thereof. Use of such information may require a license from a third party under the patents or other intellectual property of the third party, or a license from TI under the patents or other intellectual property of TI.

Reproduction of information in TI data books or data sheets is permissible only if reproduction is without alteration and is accompanied by all associated warranties, conditions, limitations, and notices. Reproduction of this information with alteration is an unfair and deceptive business practice. TI is not responsible or liable for such altered documentation.

Resale of TI products or services with statements different from or beyond the parameters stated by TI for that product or service voids all express and any implied warranties for the associated TI product or service and is an unfair and deceptive business practice. TI is not responsible or liable for any such statements.

TI products are not authorized for use in safety-critical applications (such as life support) where a failure of the TI product would reasonably be expected to cause severe personal injury or death, unless officers of the parties have executed an agreement specifically governing such use. Buyers represent that they have all necessary expertise in the safety and regulatory ramifications of their applications, and acknowledge and agree that they are solely responsible for all legal, regulatory and safety-related requirements concerning their products and any use of TI products in such safety-critical applications, notwithstanding any applications-related information or support that may be provided by TI. Further, Buyers must fully indemnify TI and its representatives against any damages arising out of the use of TI products in such safety-critical applications.

TI products are neither designed nor intended for use in military/aerospace applications or environments unless the TI products are specifically designated by TI as military-grade or "enhanced plastic." Only products designated by TI as military-grade meet military specifications. Buyers acknowledge and agree that any such use of TI products which TI has not designated as military-grade is solely at the Buyer's risk, and that they are solely responsible for compliance with all legal and regulatory requirements in connection with such use.

TI products are neither designed nor intended for use in automotive applications or environments unless the specific TI products are designated by TI as compliant with ISO/TS 16949 requirements. Buyers acknowledge and agree that, if they use any non-designated products in automotive applications, TI will not be responsible for any failure to meet such requirements.

Following are URLs where you can obtain information on other Texas Instruments products and application solutions:

Products		Applications	
Amplifiers	amplifier.ti.com	Audio	www.ti.com/audio
Data Converters	dataconverter.ti.com	Automotive	www.ti.com/automotive
DSP	dsp.ti.com	Broadband	www.ti.com/broadband
Interface	interface.ti.com	Digital Control	www.ti.com/digitalcontrol
Logic	logic.ti.com	Military	www.ti.com/military
Power Mgmt	power.ti.com	Optical Networking	www.ti.com/opticalnetwork
Microcontrollers	microcontroller.ti.com	Security	www.ti.com/security
RFID	www.ti-rfid.com	Telephony	www.ti.com/telephony
Low Power Wireless	www.ti.com/lpw	Video & Imaging	www.ti.com/video
		Wireless	www.ti.com/wireless

Mailing Address: Texas Instruments, Post Office Box 655303, Dallas, Texas 75265
Copyright © 2007, Texas Instruments Incorporated