



Integrated
Circuit
Systems, Inc.

ICS843003

FEMTOCLOCKS™ CRYSTAL-TO-3.3V LVPECL FREQUENCY SYNTHESIZER

GENERAL DESCRIPTION

The ICS843003 is a 3 differential output LVPECL Synthesizer designed to generate Ethernet reference clock frequencies and is a member of the HiPerClocks™ family of high performance clock solutions from ICS. Using a 31.25MHz or 26.041666MHz, 18pF parallel resonant crystal, the following frequencies can be generated based on the settings of 4 frequency select pins (DIV_SEL[A1:A0], DIV_SEL[B1:B0]): 625MHz, 312.5MHz, 156.25MHz, and 125MHz. The 843003 has 2 output banks, Bank A with 1 differential LVPECL output pair and Bank B with 2 differential LVPECL output pairs.

The two banks have their own dedicated frequency select pins and can be independently set for the frequencies mentioned above. The ICS843003 uses ICS'3rd generation low phase noise VCO technology and can achieve 1ps or lower typical rms phase jitter, easily meeting Ethernet jitter requirements. The ICS843003 is packaged in a small 24-pin TSSOP package.

FEATURES

- Three 3.3V LVPECL outputs on two banks, A Bank with one LVPECL pair and B Bank with 2 LVPECL output pairs
- Using a 31.25MHz or 26.041666 crystal, the two output banks can be independently set for 625MHz, 312.5MHz, 156.25MHz or 125MHz
- Selectable crystal oscillator interface or LVCMOS/LVTTL single-ended input
- VCO range: 560MHz to 700MHz
- RMS phase jitter @ 156.25MHz (1.875MHz - 20MHz): 0.51ps (typical)
- RMS phase noise at 156.25MHz
Phase noise:

Offset	Noise Power
100Hz	-96.8 dBc/Hz
1KHz	-119.1 dBc/Hz
10KHz	-126.4 dBc/Hz
100KHz	-127.0 dBc/Hz

- Full 3.3V supply mode
- 0°C to 70°C ambient operating temperature
- Industrial temperature available upon request

PIN ASSIGNMENT

DIV_SELB0	1	24	DIV_SELB1
VCO_SEL	2	23	Vcco_B
MR	3	22	QB0
Vcco_A	4	21	nQB0
QA0	5	20	QB1
nQA0	6	19	nQB1
OEB	7	18	XTAL_SEL
OEA	8	17	TEST_CLK
FB_DIV	9	16	XTAL_IN
Vcca	10	15	XTAL_OUT
Vcc	11	14	VEE
DIV_SELA0	12	13	DIV_SELA1

BLOCK DIAGRAM

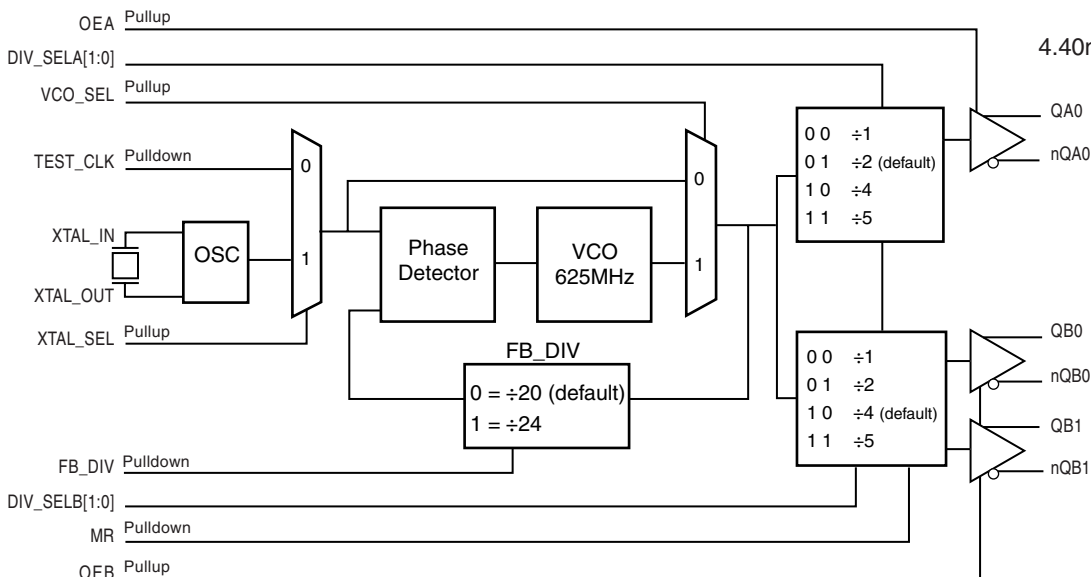

ICS843003

24-Lead TSSOP

4.40mm x 7.8mm x 0.92mm
package body
G Package
Top View



TABLE 1. PIN DESCRIPTIONS

Number	Name	Type		Description
1	DIV_SELB0	Input	Pulldown	Division select pin for Bank B. Default = Low. LVCMOS/LVTTL interface levels.
2	VCO_SEL	Input	Pullup	VCO select pin. When Low, the PLL is bypassed and the crystal reference or TEST_CLK (depending on XTAL_SEL setting) are passed directly to the output dividers. Has an internal pullup resistor so the PLL is not bypassed by default. LVCMOS/LVTTL interface levels.
3	MR	Input	Pulldown	Active HIGH Master Reset. When logic HIGH, the internal dividers are reset causing the true outputs Qx to go low and the inverted outputs nQx to go high. When logic LOW, the internal dividers and the outputs are enabled. Has an internal pulldown resistor so the power-up default state of outputs and dividers are enabled. LVCMOS/LVTTL interface levels.
4	V _{CCO_A}	Power		Output supply pin for Bank A outputs.
5, 6	QA0, nQA0	Output		Differential output pair. LVPECL interface levels.
7	OEB	Input	Pullup	Output enable Bank B. Active High output enable. When logic HIGH, the output pair on Bank B is enabled. When logic LOW, the output pair drives differential Low (QB0=Low, nQB0=High). Has an internal pullup resistor so the default power-up state of outputs are enabled. LVCMOS/LVTTL interface levels.
8	OEA	Input	Pullup	Output enable Bank A. Active High output enable. When logic HIGH, the 2 output pairs on Bank A are enabled. When logic LOW, the output pair drives differential Low (QA0=Low, nQA0=High). Has an internal pullup resistor so the default power-up state of outputs are enabled. LVCMOS/LVTTL interface levels.
9	FB_DIV	Input	Pulldown	Feedback divide select. When Low (default), the feedback divider is set for ÷20. When HIGH, the feedback divider is set for ÷24. LVCMOS/LVTTL interface levels.
10	V _{CCA}	Power		Analog supply pin.
11	V _{CC}	Power		Core supply pin.
12	DIV_SELA0	Input	Pullup	Division select pin for Bank A. Default = HIGH. LVCMOS/LVTTL interface levels.
13	DIV_SELA1	Input	Pulldown	Division select pin for Bank A. Default = Low. LVCMOS/LVTTL interface levels.
14	V _{EE}	Power		Negative supply pin.
15, 16	XTAL_OUT, XTAL_IN	Input		Parallel resonant crystal interface. XTAL_OUT is the output, XTAL_IN is the input. XTAL_IN is also the overdrive pin if you want to overdrive the crystal circuit with a single-ended reference clock.
17	TEST_CLK	Input	Pulldown	Single-ended reference clock input. Has an internal pulldown resistor to pull to low state by default. Can leave floating if using the crystal interface. LVCMOS/LVTTL interface levels.
18	XTAL_SEL	Input	Pullup	Crystal select pin. Selects between the single-ended TEST_CLK or crystal interface. Has an internal pullup resistor so the crystal interface is selected by default. LVCMOS/LVTTL interface levels.
19, 20	nQB1, QB1	Output		Differential output pair. LVPECL interface levels.
21, 22	nQB0, QB0	Output		Differential output pair. LVPECL interface levels.
23	V _{CCO_B}	Power		Output supply pin for Bank B outputs.
24	DIV_SELB1	Input	Pullup	Division select pin for Bank B. Default = High. LVCMOS/LVTTL interface levels.

NOTE: Pullup and Pulldown refer to internal input resistors. See Table 2, Pin Characteristics, for typical values.



Integrated
Circuit
Systems, Inc.

ICS843003

FEMTOCLOCKS™ CRYSTAL-TO-3.3V LVPECL
FREQUENCY SYNTHESIZER

TABLE 2. PIN CHARACTERISTICS

Symbol	Parameter	Test Conditions	Minimum	Typical	Maximum	Units
C _{IN}	Input Capacitance			4		pF
R _{PULLDOWN}	Input Pulldown Resistor			51		KΩ
R _{PULLUP}	Input Pullup Resistor			51		KΩ

TABLE 3A. BANK A FREQUENCY TABLE

Inputs				Feedback Divider	Bank A Output Divider	M/N Multiplication Factor	QA0/nQA0 Output Frequency
Crystal Frequency	DIV_SELA1	DIV_SELA0	FB_DIV				
31.25	0	0	0	20	1	20	625
31.25	0	1	0	20	2	10	312.5
31.25	1	0	0	20	4	5	156.25
31.25	1	1	0	20	5	4	125
26.041666	0	0	1	24	1	24	625
26.041666	0	1	1	24	2	12	312.5
26.041666	1	0	1	24	4	6	156.25
26.041666	1	1	1	24	5	4.8	125

TABLE 3B. BANK B FREQUENCY TABLE

Inputs				Feedback Divider	Bank B Output Divider	M/N Multiplication Factor	QBx/nQBx Output Frequency
Crystal Frequency	DIV_SELA1	DIV_SELA0	FB_DIV				
31.25	0	0	0	20	1	20	625
31.25	0	1	0	20	2	10	312.5
31.25	1	0	0	20	4	5	156.25
31.25	1	1	0	20	5	4	125
26.041666	0	0	1	24	1	24	625
26.041666	0	1	1	24	2	12	312.5
26.041666	1	0	1	24	4	6	156.25
26.041666	1	1	1	24	5	4.8	125



TABLE 3C. OUTPUT BANK CONFIGURATION SELECT FUNCTION TABLE

Inputs		Outputs	Inputs		Outputs
DIV_SELA1	DIV_SELA0	QA	DIV_SELB1	DIV_SELB0	QB
0	0	÷1	0	0	÷1
0	1	÷2	0	1	÷2
1	0	÷4	1	0	÷4
1	1	÷5	1	1	÷5

TABLE 3D. FEEDBACK DIVIDER CONFIGURATION SELECT FUNCTION TABLE

Inputs	
FB_DIV	Feedback Divide
0	÷20
1	÷24

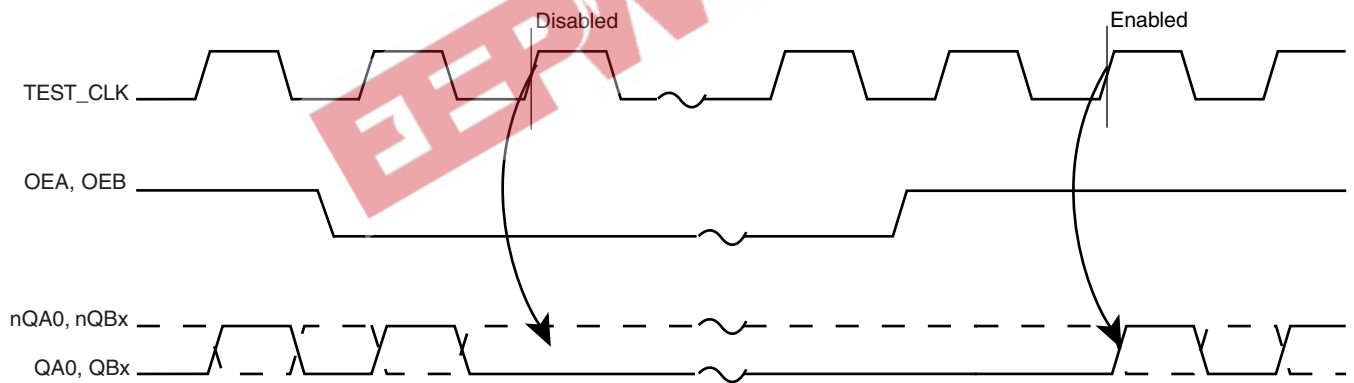

FIGURE 1. OE TIMING DIAGRAM



ABSOLUTE MAXIMUM RATINGS

Supply Voltage, V_{CC}	4.6V
Inputs, V_I	-0.5V to $V_{CC} + 0.5V$
Outputs, I_O	
Continuous Current	50mA
Surge Current	100mA
Package Thermal Impedance, θ_{JA}	70°C/W (0 lfpm)
Storage Temperature, T_{STG}	-65°C to 150°C

NOTE: Stresses beyond those listed under Absolute Maximum Ratings may cause permanent damage to the device. These ratings are stress specifications only. Functional operation of product at these conditions or any conditions beyond those listed in the *DC Characteristics* or *AC Characteristics* is not implied. Exposure to absolute maximum rating conditions for extended periods may affect product reliability.

TABLE 4A. POWER SUPPLY DC CHARACTERISTICS, $V_{CC} = V_{CCA} = V_{CCO_A} = V_{CCO_B} = 3.3V \pm 5\%$, $T_A = 0^\circ C$ TO $70^\circ C$

Symbol	Parameter	Test Conditions	Minimum	Typical	Maximum	Units
V_{CC}	Core Supply Voltage		3.135	3.3	3.465	V
V_{CCA}	Analog Supply Voltage		3.135	3.3	3.465	V
$V_{CCO_A,B}$	Output Supply Voltage		3.135	3.3	3.465	V
I_{EE}	Power Supply Current				158	mA
I_{CCA}	Analog Supply Current	Included in I_{EE}			15	mA

TABLE 4B. LVCMOS / LVTTTL DC CHARACTERISTICS, $V_{CC} = V_{CCA} = V_{CCO_A} = V_{CCO_B} = 3.3V \pm 5\%$, $T_A = 0^\circ C$ TO $70^\circ C$

Symbol	Parameter	Test Conditions	Minimum	Typical	Maximum	Units
V_{IH}	Input High Voltage		2		$V_{CC} + 0.3$	V
V_{IL}	Input Low Voltage	DIV_SELA0:A1, FB_DIV DIV_SELB0:B1, VCO_SEL, MR, OEA, OEB, XTAL_SEL	-0.3		0.8	V
		TEST_CLK	-0.3		1.3	V
I_{IH}	Input High Current	TEST_CLK, MR, FB_DIV DIV_SELA1, DIV_SELB0	$V_{CC} = V_{IN} = 3.465V$		150	μA
		DIV_SELB1, DIV_SELA0, VCO_SEL, XTAL_SEL, OEA, OEB	$V_{CC} = V_{IN} = 3.465V$		5	μA
I_{IL}	Input Low Current	TEST_CLK, MR, FB_DIV DIV_SELA1, DIV_SELB0	$V_{CC} = 3.465V, V_{IN} = 0V$	-5		μA
		DIV_SELB1, DIV_SELA0, VCO_SEL, XTAL_SEL, OEA, OEB	$V_{CC} = 3.465V, V_{IN} = 0V$	-150		μA



TABLE 4C. LVPECL DC CHARACTERISTICS, $V_{CC} = V_{CCA} = V_{CCO_A} = V_{CCO_B} = 3.3V \pm 5\%$, $T_A = 0^\circ C$ TO $70^\circ C$

Symbol	Parameter	Test Conditions	Minimum	Typical	Maximum	Units
V_{OH}	Output High Voltage; NOTE 1		$V_{CCO} - 1.4$		$V_{CCO} - 0.9$	V
V_{OL}	Output Low Voltage; NOTE 1		$V_{CCO} - 2.0$		$V_{CCO} - 1.7$	V
V_{SWING}	Peak-to-Peak Output Voltage Swing		0.6		1.0	V

NOTE 1: Outputs terminated with 50Ω to $V_{CCO} - 2V$.

TABLE 5. CRYSTAL CHARACTERISTICS

Parameter	Test Conditions	Minimum	Typical	Maximum	Units
Mode of Oscillation		Fundamental			
Frequency	FB_DIV = ± 20	28	31.25	35	MHz
	FB_DIV = ± 24	23.33	26.04166	29.167	MHz
Equivalent Series Resistance (ESR)				50	Ω
Shunt Capacitance				7	pF

NOTE: Characterized using an 18pF parallel resonant crystal.

TABLE 6. AC CHARACTERISTICS, $V_{CC} = V_{CCA} = V_{CCO_A} = V_{CCO_B} = 3.3V \pm 5\%$, $T_A = 0^\circ C$ TO $70^\circ C$

Symbol	Parameter	Test Conditions	Minimum	Typical	Maximum	Units
f_{OUT}	Output Frequency Range	DIV_SELx[1:0] = 00	560		700	MHz
		DIV_SELx[1:0] = 01	280		350	MHz
		DIV_SELx[1:0] = 10	140		175	MHz
		DIV_SELx[1:0] = 11	112		140	MHz
$t_{sk}(b)$	Bank Skew, NOTE 1			20	ps	
$t_{sk}(o)$	Output Skew; NOTE 2, 4	Outputs @ Same Frequency			35	ps
		Outputs @ Different Frequencies			100	ps
$f_{jit}(\emptyset)$	RMS Phase Jitter (Random); NOTE 3	625MHz (1.875MHz - 20MHz)		0.42		ps
		312.5MHz (1.875MHz - 20MHz)		0.50		ps
		156.25MHz (1.875MHz - 20MHz)		0.51		ps
		125MHz (1.875MHz - 20MHz)		0.52		ps
t_R / t_F	Output Rise/Fall Time	20% to 80%	250		600	ps
odc	Output Duty Cycle	DIV_SELx[1:0] = 00	40		60	%
		DIV_SELx[1:0] \neq 00	47		53	%

NOTE 1: Defined as skew within a bank of outputs at the same voltages and with equal load conditions.

NOTE 2: Defined as skew between outputs at the same supply voltages and with equal load conditions.

Measured at the output differential cross points.

NOTE 3: Please refer to the Phase Noise Plots.

NOTE 4: This parameter is defined in accordance with JEDEC Standard 65.



TYPICAL PHASE NOISE AT 125MHz

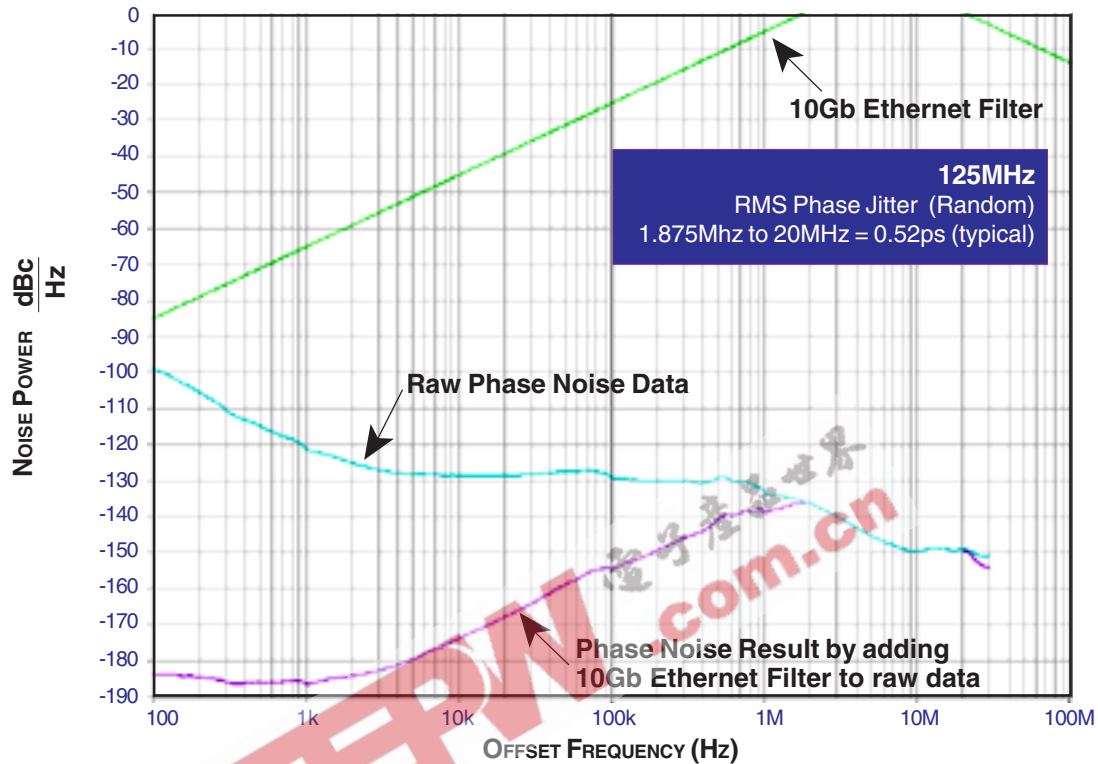

TYPICAL PHASE NOISE AT 156.25MHz

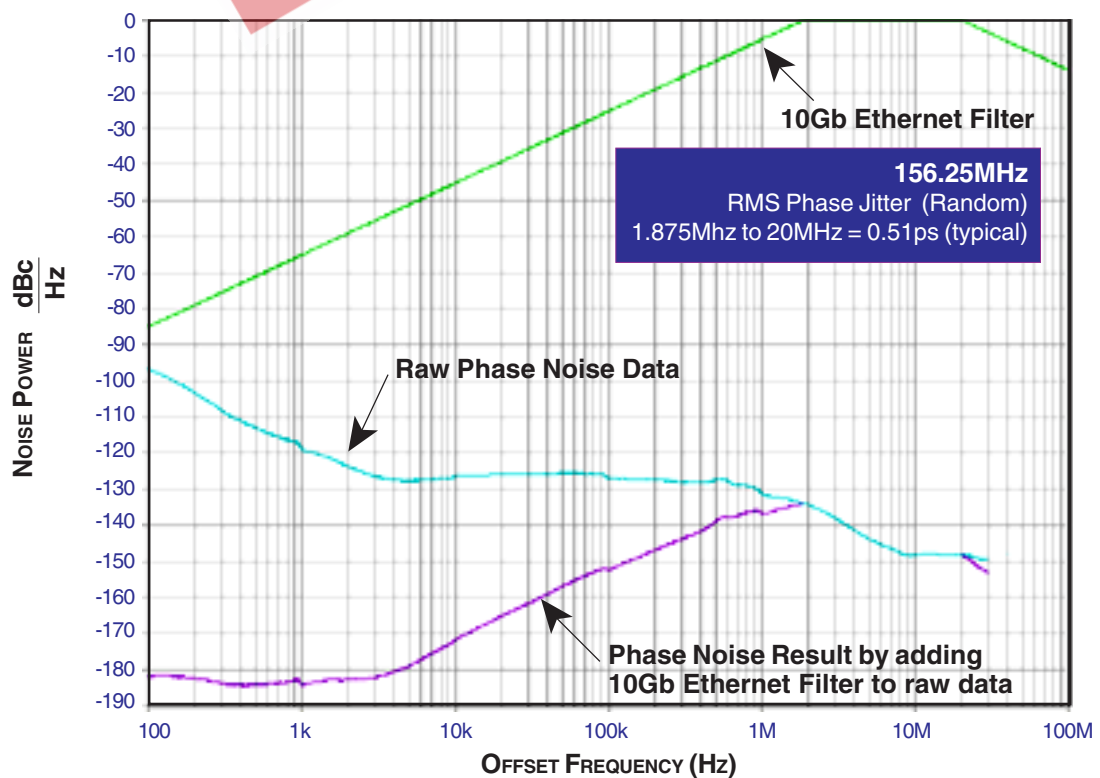



TYPICAL PHASE NOISE AT 312.5MHz

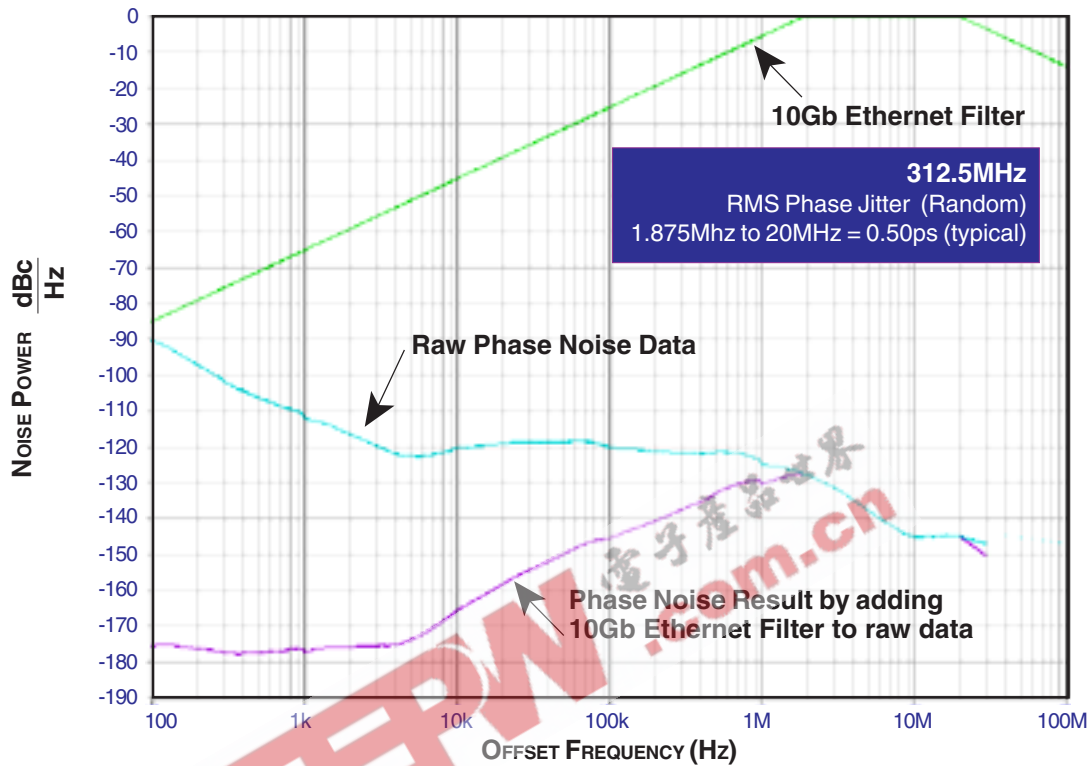

TYPICAL PHASE NOISE AT 625MHz

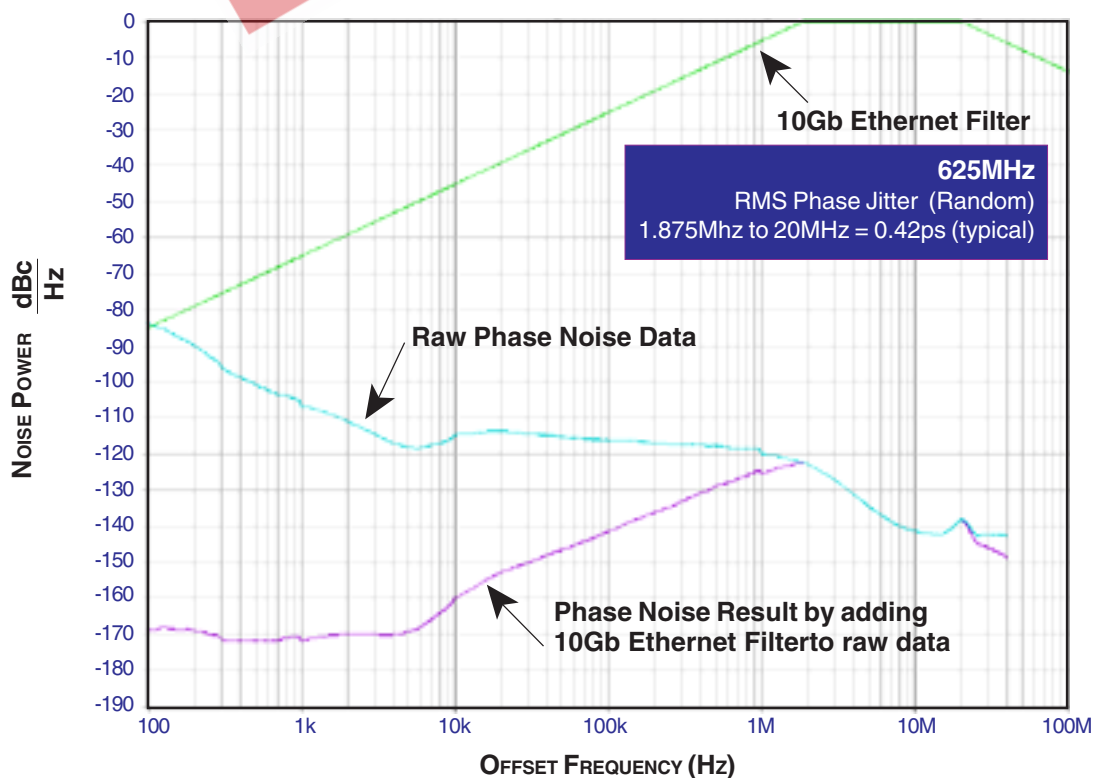



PARAMETER MEASUREMENT INFORMATION

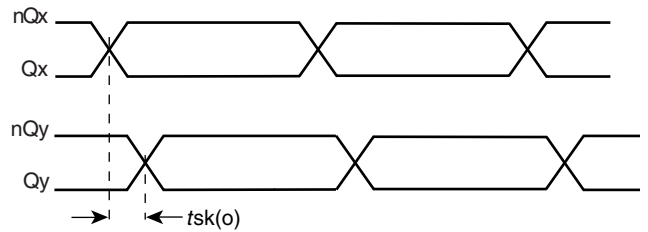
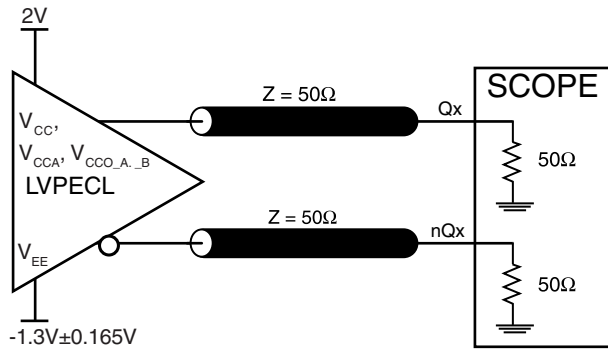

3.3V CORE/3.3V OUTPUT LOAD AC TEST CIRCUIT

OUTPUT SKEW

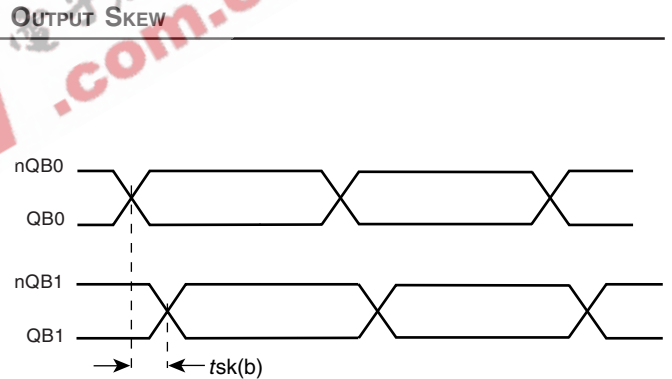
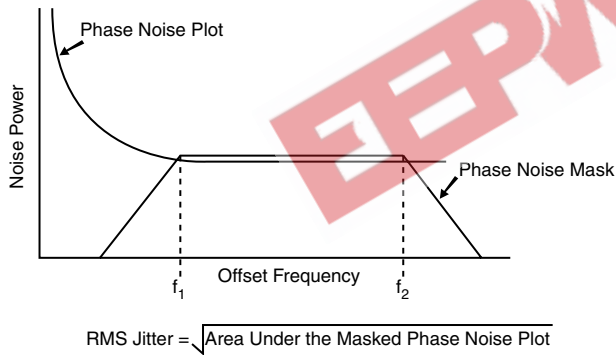

RMS PHASE JITTER

BANK SKEW

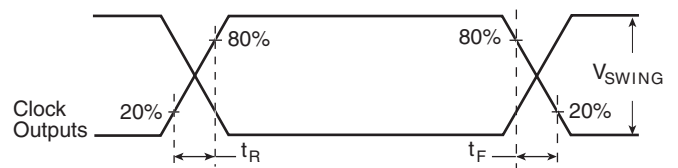
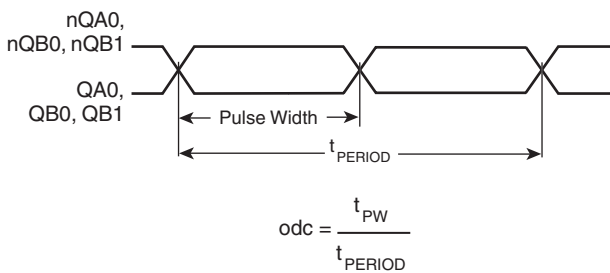

OUTPUT DUTY CYCLE/PULSE WIDTH/PERIOD

OUTPUT RISE/FALL TIME



APPLICATION INFORMATION

POWER SUPPLY FILTERING TECHNIQUES

As in any high speed analog circuitry, the power supply pins are vulnerable to random noise. The ICS843003 provides separate power supplies to isolate any high switching noise from the outputs to the internal PLL. V_{CC} , V_{CCA} , and V_{CCOX} should be individually connected to the power supply plane through vias, and bypass capacitors should be used for each pin. To achieve optimum jitter performance, power supply isolation is required. *Figure 2* illustrates how a 10Ω resistor along with a $10\mu\text{F}$ and a $.01\mu\text{F}$ bypass capacitor should be connected to each V_{CCA} pin.

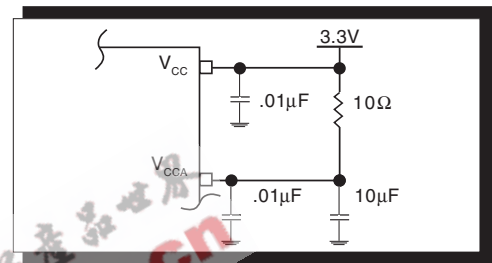

FIGURE 2. POWER SUPPLY FILTERING

CRYSTAL INPUT INTERFACE

The ICS843003 has been characterized with 18pF parallel resonant crystals. The capacitor values shown in *Figure 3* below were determined using a 31.25MHz or 26.041666MHz

18pF parallel resonant crystal and were chosen to minimize the ppm error.

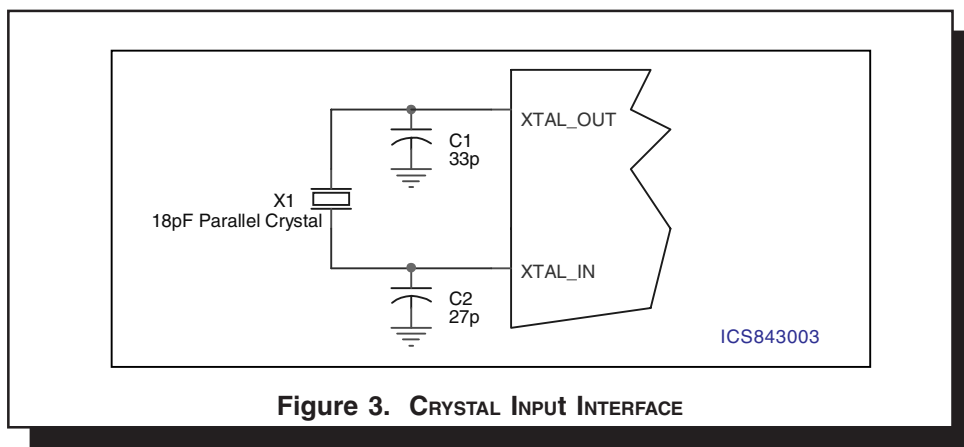

Figure 3. CRYSTAL INPUT INTERFACE



TERMINATION FOR 3.3V LVPECL OUTPUT

The clock layout topology shown below is a typical termination for LVPECL outputs. The two different layouts mentioned are recommended only as guidelines.

FOUT and nFOUT are low impedance follower outputs that generate ECL/LVPECL compatible outputs. Therefore, terminating resistors (DC current path to ground) or current sources must be used for functionality. These outputs are

designed to drive 50Ω transmission lines. Matched impedance techniques should be used to maximize operating frequency and minimize signal distortion. *Figures 4A and 4B* show two different layouts which are recommended only as guidelines. Other suitable clock layouts may exist and it would be recommended that the board designers simulate to guarantee compatibility across all printed circuit and clock component process variations.

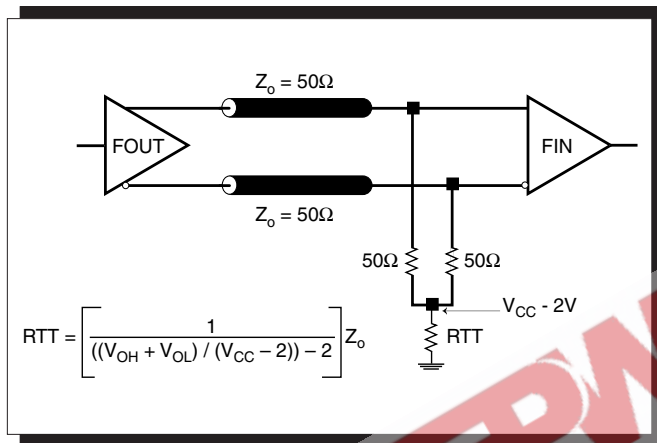

FIGURE 4A. LVPECL OUTPUT TERMINATION

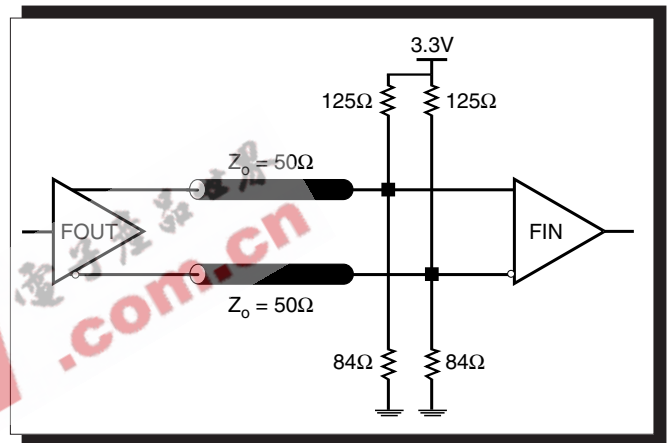

FIGURE 4B. LVPECL OUTPUT TERMINATION



LAYOUT GUIDELINE

Figure 5A shows a schematic example of the ICS843003. An example of LVEPCL termination is shown in this schematic. Additional LVPECL termination approaches are shown in the LVPECL Termination Application Note. In this example, an 18

pF parallel resonant 31.25MHz crystal is used. The C1=27pF and C2=33pF are recommended for frequency accuracy. The C1 and C2 may be slightly adjusted for optimizing frequency accuracy.

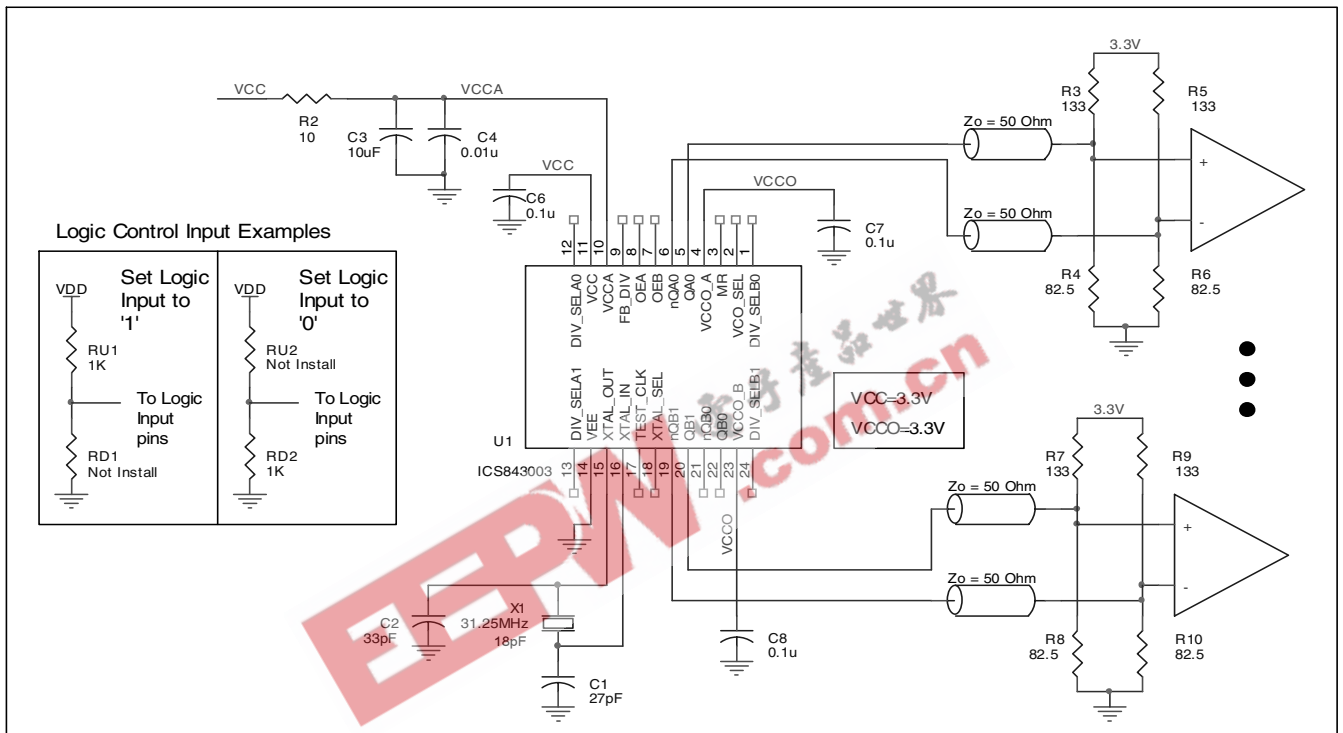

FIGURE 5A. ICS843003 SCHEMATIC EXAMPLE

PC BOARD LAYOUT EXAMPLE

Figure 5B shows an example of ICS843003 P.C. board layout. The crystal X1 footprint shown in this example allows installation of either surface mount HC49S or through-hole HC49 package. The footprints of other components in this example are listed

in the Table 7. There should be at least one decoupling capacitor per power pin. The decoupling capacitors should be located as close as possible to the power pins. The layout assumes that the board has clean analog power ground plane.

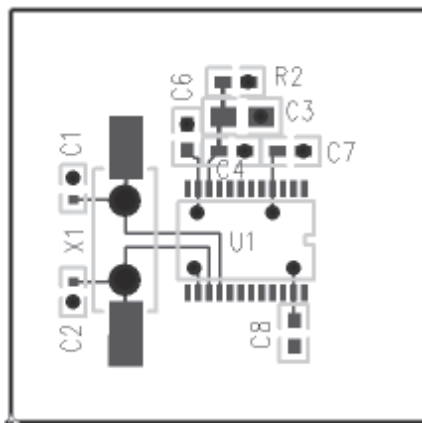

FIGURE 5B. ICS843003 PC BOARD LAYOUT EXAMPLE

TABLE 7. FOOTPRINT TABLE

Reference	Size
C1, C2	0402
C3	0805
C4, C5, C6, C7, C8	0603
R2	0603

NOTE: Table 7, lists component sizes shown in this layout example.



POWER CONSIDERATIONS

This section provides information on power dissipation and junction temperature for the ICS843003. Equations and example calculations are also provided.

1. Power Dissipation.

The total power dissipation for the ICS843003 is the sum of the core power plus the power dissipated in the load(s). The following is the power dissipation for $V_{CC} = 3.3V + 5\% = 3.465V$, which gives worst case results.

NOTE: Please refer to Section 3 for details on calculating power dissipated in the load.

- Power (core)_{MAX} = $V_{CC_MAX} * I_{EE_MAX} = 3.465V * 158mA = 547.5mW$
- Power (outputs)_{MAX} = **30mW/Loaded Output pair**
If all outputs are loaded, the total power is $3 * 30mW = 90mW$

$$\text{Total Power}_{_MAX} (3.465V, \text{ with all outputs switching}) = 547.5mW + 90mW = \mathbf{637.5mW}$$

2. Junction Temperature.

Junction temperature, T_j , is the temperature at the junction of the bond wire and bond pad and directly affects the reliability of the device. The maximum recommended junction temperature for HiPerClockS™ devices is 125°C.

The equation for T_j is as follows: $T_j = \theta_{JA} * Pd_total + T_A$

T_j = Junction Temperature

θ_{JA} = Junction-to-Ambient Thermal Resistance

Pd_total = Total Device Power Dissipation (example calculation is in section 1 above)

T_A = Ambient Temperature

In order to calculate junction temperature, the appropriate junction-to-ambient thermal resistance θ_{JA} must be used. Assuming a moderate air flow of 1 meter per second and a multi-layer board, the appropriate value is 65°C/W per Table 8 below.

Therefore, T_j for an ambient temperature of 70°C with all outputs switching is:

$$70^\circ C + 0.638W * 65^\circ C/W = 111.5^\circ C. \text{ This is well below the limit of } 125^\circ C.$$

This calculation is only an example. T_j will obviously vary depending on the number of loaded outputs, supply voltage, air flow, and the type of board (single layer or multi-layer).

TABLE 8. THERMAL RESISTANCE θ_{JA} FOR 24-PIN TSSOP, FORCED CONVECTION

θ_{JA} by Velocity (Meters per Second)			
	0	1	2.5
Multi-Layer PCB, JEDEC Standard Test Boards	70°C/W	65°C/W	62°C/W



3. Calculations and Equations.

The purpose of this section is to derive the power dissipated into the load.
LVPECL output driver circuit and termination are shown in *Figure 6*.

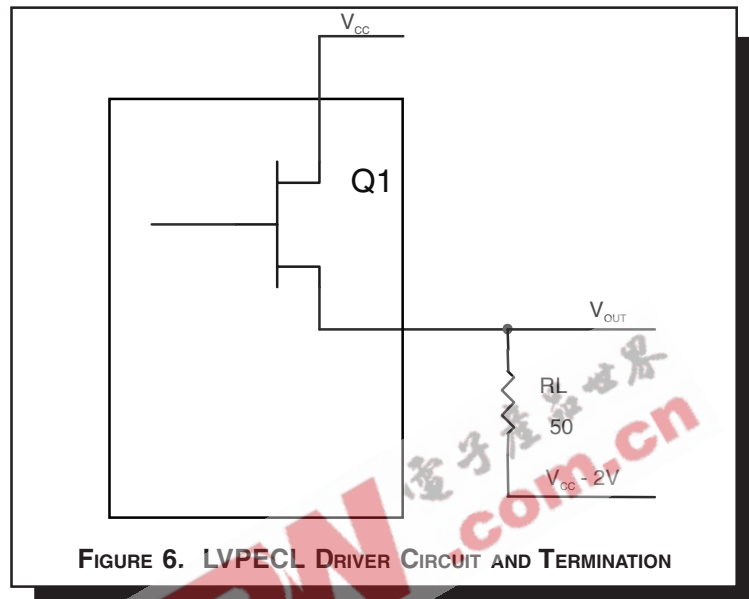

FIGURE 6. LVPECL DRIVER CIRCUIT AND TERMINATION

To calculate worst case power dissipation into the load, use the following equations which assume a 50Ω load, and a termination voltage of $V_{CC} - 2V$.

- For logic high, $V_{OUT} = V_{OH_MAX} = V_{CC_MAX} - 0.9V$
 $(V_{CC_MAX} - V_{OH_MAX}) = 0.9V$
- For logic low, $V_{OUT} = V_{OL_MAX} = V_{CC_MAX} - 1.7V$
 $(V_{CC_MAX} - V_{OL_MAX}) = 1.7V$

Pd_H is power dissipation when the output drives high.
 Pd_L is the power dissipation when the output drives low.

$$Pd_H = [(V_{OH_MAX} - (V_{CC_MAX} - 2V))/R_L] * (V_{CC_MAX} - V_{OH_MAX}) = [(2V - (V_{CC_MAX} - V_{OH_MAX}))/R_L] * (V_{CC_MAX} - V_{OH_MAX}) = [(2V - 0.9V)/50\Omega] * 0.9V = 19.8mW$$

$$Pd_L = [(V_{OL_MAX} - (V_{CC_MAX} - 2V))/R_L] * (V_{CC_MAX} - V_{OL_MAX}) = [(2V - (V_{CC_MAX} - V_{OL_MAX}))/R_L] * (V_{CC_MAX} - V_{OL_MAX}) = [(2V - 1.7V)/50\Omega] * 1.7V = 10.2mW$$

Total Power Dissipation per output pair = $Pd_H + Pd_L = 30mW$



Integrated
Circuit
Systems, Inc.

ICS843003
FEMTOCLOCKS™ CRYSTAL-TO-3.3V LVPECL
FREQUENCY SYNTHESIZER

RELIABILITY INFORMATION

TABLE 9. θ_{JA} vs. AIR FLOW TABLE FOR 24 LEAD TSSOP

θ_{JA} by Velocity (Meters per Second)			
	0	1	2.5
Multi-Layer PCB, JEDEC Standard Test Boards	70°C/W	65°C/W	62°C/W

TRANSISTOR COUNT

The transistor count for ICS843003 is: 3767

EEPW.com.cn 电子产品世界



PACKAGE OUTLINE - G SUFFIX FOR 24 LEAD TSSOP

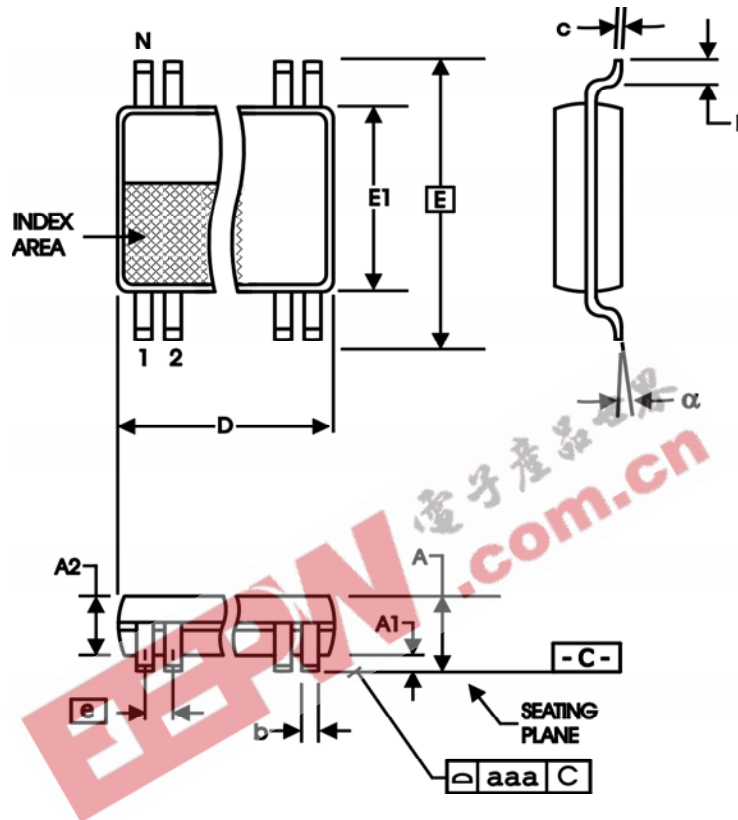

TABLE 10. PACKAGE DIMENSIONS

SYMBOL	Millimeters	
	Minimum	Maximum
N	24	
A	--	1.20
A1	0.05	0.15
A2	0.80	1.05
b	0.19	0.30
c	0.09	0.20
D	7.70	7.90
E	6.40 BASIC	
E1	4.30	4.50
e	0.65 BASIC	
L	0.45	0.75
alpha	0°	8°
aaa	--	0.10

Reference Document: JEDEC Publication 95, MO-153



Integrated
Circuit
Systems, Inc.

ICS843003
FEMTOCLOCKS™ CRYSTAL-TO-3.3V LVPECL
FREQUENCY SYNTHESIZER

TABLE 11. ORDERING INFORMATION

Part/Order Number	Marking	Package	Count	Temperature
ICS843003AG	ICS843003AG	24 Lead TSSOP	60 per tube	0°C to 70°C
ICS843003AGT	ICS843003AG	24 Lead TSSOP on Tape and Reel	2500	0°C to 70°C

EEPW 电子产品世界
.com.cn

The aforementioned trademarks, HiPerClockS™ and FemtoClocks™ are a trademark of Integrated Circuit Systems, Inc. or its subsidiaries in the United States and/or other countries. While the information presented herein has been checked for both accuracy and reliability, Integrated Circuit Systems, Incorporated (ICS) assumes no responsibility for either its use or for infringement of any patents or other rights of third parties, which would result from its use. No other circuits, patents, or licenses are implied. This product is intended for use in normal commercial applications. Any other applications such as those requiring extended temperature range, high reliability, or other extraordinary environmental requirements are not recommended without additional processing by ICS. ICS reserves the right to change any circuitry or specifications without notice. ICS does not authorize or warrant any ICS product for use in life support devices or critical medical instruments.